



Heating and Air Conditioning

TECHNICAL GUIDE

SPLIT-SYSTEM AIR CONDITIONERS

12 SEER

MODELS:

H*RC018 THRU 060
(1.5 THRU 5 NOMINAL TONS, 1 PH)

H*RC036S(25,46) THRU 060
(3 THRU 5 NOMINAL TONS, 3 PH)



CERTIFICATION APPLIES ONLY
WHEN THE COMPLETE
SYSTEM IS LISTED
WITH ARI.



Due to continuous product improvement, specifications are subject to change without notice.

Visit us on the web at www.york.com for the most up-to-date technical information.

Additional rating information can be found at www.ariprinenet.org.

DESCRIPTION

The 12 SEER Series condensing unit is the outdoor part of a versatile system of air conditioning. It is designed to be custom-matched with one of UPG's complete line of evaporator sections, each designed to serve a specific function. Matching Air Handlers are available for upflow, downflow or horizontal applications to provide a complete system. Electric Heaters are available if required. Add-On coils are available for use with upflow, downflow or horizontal furnaces and air handlers.

WARRANTY

Single Phase Units:

5-year limited parts warranty.

10-year limited compressor warranty.

Three Phase Units:

1-year limited parts warranty.

5-year limited compressor warranty.

FEATURES

- **QUALITY CONDENSER COILS** - The coil is constructed of enhanced copper tube and aluminum fins.
- **COIL PROTECTION** - Coils are protected from damage by a polymer mesh applied between the coil face, and a PVC coated steel coil guard.
- **PROTECTED COMPRESSOR** - The compressor is internally protected against high pressure and temperature. This is accomplished by the simultaneous operation of high pressure relief valve and a temperature sensor which protects the compressor if undesirable operating conditions occur. A liquid line filter-drier further protects the compressor.
- **DURABLE FINISH** - The cabinet is made of pre-painted steel. The pre-treated galvanized steel provides a better paint to steel bond, which resists corrosion and rust creep. Special primer formulas and matted textured desert sand finish insure less fading when exposed to sunlight.
- **LOWER INSTALLED COST** - Installation time and costs are reduced by easy power and control wiring connections. Discharge line heat exchanger knockouts are provided, if required. Available in sweat connect models only. The unit contains enough refrigerant for matching indoor coils and 15 feet of interconnecting piping. The small base dimension means less space is required on the ground or roof.
- **TOP DISCHARGE** - The warm air from the top mounted fan is blown up away from the structure and any landscaping. This allows compact location on multi-unit applications.
- **LOW OPERATING SOUND LEVEL** - The upward air flow carries the normal operating noise up away from the living area. The rigid top panel effectively isolates any motor sound. Isolator mounted compressor and the rippled fins of the condenser coil muffle the normal fan motor and compressor operating sounds.
- **LOW MAINTENANCE** - Long life permanently lubricated motor-bearings need no annual servicing.
- **EASY SERVICE ACCESS** - Fully exposed refrigerant connections, a single panel covering the electrical controls and the molex plug in the control box connecting the condenser fan, make for easy servicing of the unit.
- **SECURED SERVICE VALVES** - Secured re-usable service valves are provided on both the liquid and vapor sweat connections for ease of evacuating and charging.
- **U.L. and C.U.L. listed** - approved for outdoor application.

Certified in accordance with the Unitary Small Equipment certification program, which is based on ARI Standard 210/240.

PHYSICAL AND ELECTRICAL DATA - 1 Phase

MODEL		H2RC018S06	H2RC024S06	H2RC030S06	H2RC036S06	H2RC042S06	H2RC048S06	H3RC060S06
Unit Supply Voltage		208/230 – 1 – 60						
Normal Voltage Range ¹		187 to 252						
Minimum Circuit Ampacity		10.1	14.1	16.5	19.7	26.2	28.5	37.4
Max. Overcurrent Device Amps ²		15	25	25	30	45	50	60
Compressor Type ³		Recip	Inertia	Recip	Recip	Scroll ^B	Recip	Scroll ^C
Compressor Amps	Rated Load	7.7	10.9	12.8	14.7	19.9	21.8	28.8
	Locked Rotor	48	60	68	82	115	105	169
Crankcase Heater		No	No	No	Yes	No	No	No
Fan Motor Amps	Rated Load	0.5	0.5	0.5	1.3	1.3	1.3	1.3
Fan Diameter Inches		18	18	22	22	22	22	22
Fan Motor	Rated HP	1/12	1/12	1/15	1/4	1/4	1/4	1/4
	Nominal RPM	1,100	1,100	850	850	850	850	850
	Nominal CFM	2,000	2,000	2,300	3,300	3,300	3,300	3,400
Coil	Face Area Sq. Ft.	12.58	12.58	15.72	15.72	17.03	19.65	23.58
	Rows Deep	1	1	1	1	1	1	1
	Fin / Inches	18	18	18	18	18	18	18
Liquid Line OD		3/8	3/8	3/8	3/8	3/8	3/8	3/8
Vapor Line OD		3/4	3/4	3/4	3/4	7/8	7/8	7/8
Unit Charge (Lbs. - Oz.) ⁴		4 - 9	4 - 7	5 - 8	5 - 3	6 - 13	7 - 7	9 - 0
Charge Per Foot, Oz.		0.68	0.68	0.68	0.68	0.70	0.70	0.70

1. Rated in accordance with ARI Standard 110, utilization range "A".
2. Dual element fuses or HACR circuit breaker.
3. All scrolls listed with a superscript "B" are Bristol scrolls. All scrolls listed with a superscript "C" are Copeland scrolls.
4. The Unit Charge is correct for the outdoor unit, matched indoor coil and 15 feet of refrigerant tubing. For tubing lengths other than 15 feet, add or subtract the amount of refrigerant, using the difference in length multiplied by the per foot value.

PHYSICAL AND ELECTRICAL DATA - 3 Phase

MODEL		H1RC036S25	H1RC048S25	H1RC060S25		H1RC036S46	H1RC048S46	H1RC060S46	
Unit Supply Voltage		208/230 – 3 – 60					460 - 3 - 60		
Normal Voltage Range ¹		187 to 252					432 to 504		
Minimum Circuit Ampacity		13.3	18.9	22.9		7.6	9.6	12.0	
Max. Overcurrent Device Amps ²		20	30	40		15	15	20	
Compressor Type		Inertia	Inertia	Scroll		Inertia	Inertia	Scroll	
Compressor Amps	Rated Load	9.6	14.1	17.3		5.4	7.0	9.0	
	Locked Rotor	78.0	130.0	123.0		40.0	64.0	62.0	
Crankcase Heater		No	No	No		No	No	No	
Fan Motor Amps	Rated Load	1.3	1.3	1.3		0.8	0.8	0.8	
Fan Diameter Inches		22	22	22		22	22	22	
Fan Motor	Rated HP	1/4	1/4	1/4		1/4	1/4	1/4	
	Nominal RPM	850	850	850		850	850	850	
	Nominal CFM	3,300	3,300	3,400		3,300	3,300	3,400	
Coil	Face Area Sq. Ft.	15.72	17.03	23.58		15.72	17.03	23.58	
	Rows Deep	1	1	1		1	1	1	
	Fin / Inches	18	18	18		18	18	18	
Liquid Line OD		3/8	3/8	3/8		3/8	3/8	3/8	
Vapor Line OD		3/4	7/8	1-1/8		3/4	7/8	1-1/8	
Unit Charge (Lbs. - Oz.) ³		6 - 2	7 - 10	9 - 3		6 - 2	7 - 10	9 - 3	
Charge Per Foot, Oz.		0.68	0.70	0.76		0.68	0.70	0.76	
Operating Weight Lbs.		157	184	198		157	184	198	

1. Rated in accordance with ARI Standard 110, utilization range "A".
2. Dual element fuses or HACR circuit breaker.
3. The Unit Charge is correct for the outdoor unit, matched indoor coil and 15 feet of refrigerant tubing. For tubing lengths other than 15 feet, add or subtract the amount of refrigerant, using the difference in length multiplied by the per foot value.

Additional R-22 Charge / Orifice Size for Various Matched Systems - 1 Phase

Outdoor Unit	H2RC018S06	H2RC024S06	H2RC030S06	H2RC036S06	H2RC042S06	H2RC048S06	H3RC060S06
Unit Orifice (s) ¹	53	59	63	73	78	87	–
Factory R-22 Charge, lbs-oz.	4 - 9	4 - 7	5 - 8	5 - 3	6 - 13	7 - 7	9 - 0
Indoor Coil	Coil Orifice	Orifice or TXV Kit ² - Additional Charge, Oz. ³					
G2FD024S(H)14,17	61	53 + 3	59 + 3	–	–	–	–
		701 + 3	701 + 3	–	–	–	–
G2FD030S(H)17	65	53 + 6	59 + 6	63 + 4	–	–	–
		701 + 6	701 + 6	701 + 4	–	–	–
G2FD035S(H)14	65	53 + 6	59 + 6	63 + 4	73 + 0	–	–
		701 + 6	701 + 6	701 + 4	702 + 0	–	–
G2FD036S(H)17	75	–	59 + 10	63 + 8	73 + 6	–	–
		–	701 + 10	701 + 8	702 + 6	–	–
G2FD036S(H)21	75	–	–	63 + 11	73 + 8	–	–
		–	–	701 + 11	702 + 8	–	–
G2FD042S(H)21	78	–	–	63 + 14	73 + 12	78 + 0	–
		–	–	701 + 14	702 + 12	702 + 0	–
G2FD046S(H)17	78	–	–	63 + 16	73 + 12	78 + 0	87 + 0
		–	–	701 + 16	702 + 12	702 + 0	703 + 0
G2FD048S(H)21,24	84	–	–	–	73 + 16	78 + 10	87 + 11
		–	–	–	702 + 16	702 + 10	703 + 11
G2FD060S(H)24	90	–	–	–	–	–	87 + 15
		–	–	–	–	–	703 + 15
G2FD061H24	90	–	–	–	–	–	87 + 19
		–	–	–	–	–	703 + 19
G1HD024	59	53 + 5	59 + 4	–	–	–	–
		701 + 5	701 + 4	–	–	–	–
G1HD036	69	–	59 + 13	63 + 11	73 + 7	–	–
		–	701 + 13	701 + 11	702 + 7	–	–
G1HD048	81	–	–	–	73 + 13	78 + 3	87 + 4
		–	–	–	702 + 13	702 + 3	703 + 4
G1HD060	93	–	–	–	–	–	87 + 12
		–	–	–	–	–	703 + 12
G1FA/G1UA024S14,17	59	53 + 0	59 + 0	–	–	–	–
		701 + 0	701 + 0	–	–	–	–
G1FA/G1UA030S14	65	–	59 + 3	63 + 0	–	–	–
		–	701 + 3	701 + 0	–	–	–
G1FA/G1UA036S14	73	–	59 + 8	63 + 6	73 + 3	–	–
		–	701 + 8	701 + 6	702 + 3	–	–
G1FA/G1UA036S17,21	73	–	59 + 6	63 + 4	73 + 0	–	–
		–	701 + 6	701 + 4	702 + 0	–	–
G1FA/G1UA048S17	84	–	–	63 + 16	73 + 13	78 + 0	87 + 0
		–	–	701 + 16	702 + 13	702 + 0	703 + 0
G1FA/G1UA048S21	84	–	–	63 + 18	73 + 9	78 + 7	87 + 8
		–	–	701 + 18	702 + 9	702 + 7	703 + 8
G1FA/G1UA060S21,24	90	–	–	–	–	78 + 16	87 + 15
		–	–	–	–	702 + 16	703 + 15
G1NA030S17K	63	53 + 6	59 + 6	63 + 4	–	–	–
		701 + 6	701 + 6	701 + 4	–	–	–
G1NA030S21M	78	53 + 6	59 + 6	63 + 4	–	–	–
		701 + 6	701 + 6	701 + 4	–	–	–
G1NA036S17L	63	–	–	63 + 15	73 + 12	–	–
		–	–	701 + 15	702 + 12	–	–
G1NA048S21D	78	–	–	–	73 + 12	78 + 0	87 + 0
		–	–	–	702 + 12	702 + 0	703 + 0
G1NA048S24P	63	–	–	–	73 + 13	78 + 2	87 + 1
		–	–	–	702 + 13	702 + 2	703 + 1

Additional R-22 Charge / Orifice Size for Various Matched Systems - 1 Phase (Continued)

Outdoor Unit	H2RC018S06	H2RC024S06	H2RC030S06	H2RC036S06	H2RC042S06	H2RC048S06	H3RC060S06
Unit Orifice (s) ¹	53	59	63	73	78	87	-
Factory R-22 Charge, lbs-oz.	4 - 9	4 - 7	5 - 8	5 - 3	6 - 13	7 - 7	9 - 0
Indoor Coil	Coil Orifice	Orifice or TXV Kit ² - Additional Charge, Oz. ³					
G1NA060S24T	78	-	-	-	-	-	-
		-	-	-	-	-	-
G1NF024SOF	63	-	-	-	-	-	-
		-	-	-	-	-	-
G1NF036SOF	67	-	59 + 12	63 + 0	73 + 7	-	-
		-	701 + 12	701 + 0	702 + 7	-	-
G1NF048SOF	78	-	-	-	-	78 + 21	87 + 6
		-	-	-	-	702 + 21	703 + 6
G1NF060SOF	87	-	-	-	-	-	87 + 18
		-	-	-	-	-	703 + 18
F2RP024N06	61	53 + 4	59 + 4	-	-	-	-
		701 + 4	701 + 4	-	-	-	-
F2RP030N06	65	-	59 + 6	63 + 4	-	-	-
		-	701 + 6	701 + 4	-	-	-
F2RP036N06	75	-	-	63 + 4	73 + 8	-	-
		-	-	701 + 4	702 + 8	-	-
F2RP042N06	78	-	-	-	73 + 13	78 + 0	-
		-	-	-	702 + 13	702 + 0	-
F2FP048N06	84	-	-	-	73 + 16	78 + 10	87 + 11
		-	-	-	702 + 16	702 + 10	703 + 11
F2FP060N06	90	-	-	-	-	-	87 + 15
		-	-	-	-	-	703 + 15
F2FV060N06	90	-	-	-	-	-	87 + 15
		-	-	-	-	-	703 + 15

FOOTNOTES:

1. These orifices are factory mounted in the flow control device of each indoor coil and must be removed for TXV installation.
2. A TXV kit must be used with these coils to obtain system performance. (701,702,703 indicates 1TV07 ...series).
3. Systems matched with furnaces or air handlers not equipped with blower-off delays, may require blower Time Delay Kit #6918A5011.

PROCEDURES:

1. Unit factory charge listed on the unit nameplate includes refrigerant for the condenser, the smallest evaporator and for 15 feet of interconnecting line tubing.
2. Verify the orifice size and additional charge required for specific evaporator coil in the system using the above table.
3. Additional charge for the amount of interconnecting line tubing greater than 15 feet at the rate specified in the table above.
4. Permanently mark the unit nameplate with the total system charge. Total System Charge = Base Charge (as shipped) + adder for evaporator + adder for line set.
5. If the orifice in the evaporator was changed, verify the evaporator nameplate has been marked with the correct orifice size.

Additional R-22 Charge / Orifice Size for Various Matched Systems - 3 Phase

Outdoor Unit				H1RC036S	H1RC048S	H1RC060S		
Unit Orifice (s) ¹				—	—	—		
Factory R-22 Charge, lbs-oz				6 - 2	7 - 10	9 - 3		
Indoor Coil	Coil Orifice	TVX Kit ² = Additional Charge, Oz ³						
G2FD035S(H)14	65			702 + 0	—	—		
G2FD036S(H)17,21	75			702 + 3	—	—		
G2FD042S(H)21	78			702 + 0	—	—		
G2FD046S(H)17	78			702 + 9	703 + 0	—		
G2FD048S(H)21,24	84			702 + 17	703 + 9	—		
G2FD060S(H)24	90			—	703 + 0	703 + 20		
G2FD061H24	90			—	703 + 6	703 + 25		
G1FA/G1UA036S14	73			702 + 1	—	—		
G1FA/G1UA036S17,21	73			702 + 0	—	—		
G1FA/G1UA048S17	84			—	703 + 2	—		
G1FA/G1UA048S21,24	84			702 + 9	703 + 7	—		
G1FA/G1UA060S21,24	90			—	703 + 14	703 + 20		
G1NA036S17L	71			702 + 0	—	—		
G1NA048S21D	78			702 + 0	703 + 0	—		
G1NA048S24P	78			702 + 0	703 + 0	—		
G1NA060S24T	87			—	—	703 + 0		
G1NF036SOF	67			702 + 0	—	—		
G1NF048SOF	78			—	702 + 0	—		
G1NF060SOF	87			—	—	703 + 0		
G1HD036	69			702 + 5	—	—		
G1HD048	81			702 + 11	703 + 0	—		
G1HD060	93			—	703 + 0	703 + 20		

1. These orifices are factory mounted in the flow control device of each indoor coil and must be removed for TXV installation.
2. A TXV kit must be used with these coils to obtain system performance. (701,702,703 indicates 1TV07 ...series).
3. Systems matched with furnaces or air handlers not equipped with blower-off delays, may require blower Time Delay Kit #6918A5011.

FOOTNOTES:

1. These orifices are factory mounted in the flow control device of each indoor coil and must be removed for TXV installation.
2. A TXV kit must be used with these coils to obtain system performance. (701,702,703 indicates 1TV07 ...series).
3. Systems matched with furnaces or air handlers not equipped with blower-off delays, may require blower Time Delay Kit #6918A5011.

PROCEDURES:

6. Unit factory charge listed on the unit nameplate includes refrigerant for the condenser, the smallest evaporator and for 15 feet of interconnecting line tubing.
7. Verify the orifice size and additional charge required for specific evaporator coil in the system using the above table.
8. Additional charge for the amount of interconnecting line tubing greater than 15 feet at the rate specified in the table above.
9. Permanently mark the unit nameplate with the total system charge. Total System Charge = Base Charge (as shipped) + adder for evaporator + adder for line set.
10. If the orifice in the evaporator was changed, verify the evaporator nameplate has been marked with the correct orifice size.

COOLING CAPACITY - With Air Handler Coils

UNIT MODEL	AIR HANDLER			COIL ¹ MODEL	COOLING					
	MODEL	ELECTRIC ² HEAT KW	W		RATED CFM	NET MBH		SEER W/O TXV	SEER WITH TXV ³	EER
						TOTAL	SENS.			
1 PH 12 SEER AC WITH N1AH / G2FD										
H2RC018S06	N1AHB0806	2,5,8,10	17	G2FD024(S,H)17	600	19.6	13.2	12.50	12.50	11.60
H2RC024S06	N1AHB0806	2,5,8,10	17	G2FD024(S,H)17	750	23.6	16.9	12.00	12.00	11.00
	N1AHB0806	2,5,8,10	17	G2FD030(S,H)17	750	24.0	17.3	12.00	12.00	11.10
H2RC030S06	N1AHB1206	2,5,8,10	17	G2FD030(S,H)17	1000	30.0	21.3	12.00	12.00	11.00
	N1AHB1206	2,5,8,10	17	G2FD036(S,H)17	1000	30.6	21.8	12.25	12.25	11.20
H2RC036S06	N1AHB1206	5,8,10,15,19	17	G2FD036(S,H)17	1200	33.8	23.6	11.50	11.50	10.70
	N1AHB1206	5,8,10,15,19	17	G2FD046(S,H)17	1200	35.0	24.4	12.00	12.00	10.90
H2RC042S06	N1AHC1606	5,8,10,15,20	21	G2FD042(S,H)21	1400	41.0	29.3	12.00	-	10.50
	N1AHC1606	5,8,10,15,20	21	G2FD048(S,H)24	1400	42.5	30.6	12.00	-	10.75
H2RC048S06	N1AHC1606	5,8,10,15,20	21	G2FD048(S,H)24	1575	46.5	36.0	12.20	12.20	10.90
	N1AHD2006	8,10,15,20,25,30	24	G2FD060(S,H)24	1575	48.0	36.4	12.50	12.50	11.10
	N1AHD2006	8,10,15,20,25,30	24	G2FD061H24	1575	48.5	34.5	12.50	12.50	11.20
H3RC060S06	N1AHD2006	8,10,15,20,25,30	24	G2FD060(S,H)24	1800	57.5	42.6	-	12.00	10.40
	N1AHD2006	8,10,15,20,25,30	24	G2FD061H24	1850	58.0	43.2	-	12.00	10.45
3 PH 12 SEER AC WITH N1AH / G2FD										
H1RC036S(25,46)	N1AHB1246	5,8,10,15,18	17	G2FD036(S,H)17	1255	33.6	24.9	--	12.00	10.65
	N1AHB1246	5,8,10,15,18	17	G2FD046(S,H)17	1250	34.8	25.8	--	12.00	10.95
	N1AHC1646	5,8,10,15,18	21	G2FD048(S,H)21	1600	45.5	33.7	--	12.20	11.20
H1RC048S(25,46)	N1AHD2046	8,10,15,20,25,30	24	G2FD060(S,H)24	1620	47.0	34.8	--	12.50	11.45
	N1AHD2046	8,10,15,20,25,30	24	G2FD061H24	1600	47.5	35.2	--	12.50	11.50
H1RC060S(25,46)	N1AHD2046	8,10,15,20,25,30	24	G2FD060(S,H)24	1800	57.5	42.6	--	12.00	10.40
	N1AHD2046	8,10,15,20,25,30	24	G2FD061H24	1850	58.0	43.2	--	12.00	10.45
1 PH 12 SEER / N1VS - VARIABLE SPEED										
H2RC018S06	N1VSB12	10,15,18	17	G2FD024(S,H)17	650	20.2	13.2	13.75	13.75	12.80
H2RC024S06	N1VSB12	10,15,18	17	G2FD024(S,H)17	725	24.2	16.9	13.35	13.35	12.15
	N1VSB12	10,15,18	17	G2FD036(S,H)17	775	25.2	17.8	13.50	13.50	12.50
H2RC030S06	N1VSB12	10,15,18	17	G2FD036(S,H)17	1000	31.0	21.9	13.25	13.25	12.15
	N1VSB12	10,15,18	17	G2FD046(S,H)17	1000	32.0	22.3	13.75	13.75	12.55
	N1VSB12	10,15,18	17	G2FD046(S,H)17	1000	32.0	22.3	13.75	13.75	12.55
H2RC036S06	N1VSB12	10,15,18	17	G2FD036(S,H)17	1200	34.8	23.6	12.40	12.40	11.35
	N1VSB12	10,15,18	17	G2FD046(S,H)17	1210	35.8	24.4	13.00	13.00	11.65
	N1VSC16	10,15,18	21	G2FD048(S,H)21	1155	36.8	25.1	13.40	13.40	12.20
H2RC042S06	N1VSC16	10,15,18	21	G2FD048(S,H)21	1400	43.0	30.6	13.00	-	11.55
	N1VSC16	10,15,18	21	G2FD048(S,H)21	1590	47.0	30.6	12.80	-	11.40
H2RC048S06	N1VSC16	10,15,18	21	G2FD048(S,H)21	1590	47.0	34.9	12.80	12.80	11.40
	N1VSD20	10,15,18,30	24	G2FD060(S,H)24	1560	48.5	36.0	13.25	13.25	11.75
	N1VSD20	10,15,18,30	24	G2FD061H24	1560	49.0	36.4	13.30	13.30	11.90
H3RC060S06	N1VSD20	10,15,18,30	24	G2FD060(S,H)24	1780	57.5	42.6	-	12.25	10.65
	N1VSD20	10,15,18,30	24	G2FD061H24	1780	58.0	43.2	-	12.40	10.80
1 PH 12 SEER AC / F2RP / RC / FC^{4,5}										
H2RC018S06	F2RC/F2FC024	5,8,10	18	-	600	20.0	13.2	12.50	12.50	11.70
	F2RP/F2FP024	5,8,10	18	-	600	20.0	13.2	12.50	12.50	11.70
H2RC024S06	F2RC/F2FC024	5,8,10	18	-	750	23.4	17.5	11.50	11.50	10.85
	F2RC/F2FC030	5,8,10,15	18	-	750	23.4	17.5	11.50	11.50	10.85
	F2RP/F2FP024	5,8,10	18	-	750	23.6	17.5	12.00	12.00	10.90
H2RC030S06	F2RP/F2FP030	5,8,10,15	18	-	750	24.0	17.9	12.00	12.00	11.10
	F2RC/F2FC030	5,8,10,15	18	-	1000	29.8	21.5	12.00	12.00	11.00
	F2RC/F2FC036	5,8,10,15	21	-	1000	31.0	22.4	12.25	12.25	11.30
	F2RP/F2FP030	5,8,10,15	18	-	1000	30.2	22.9	12.00	12.00	11.15
	F2RP/F2FP036	5,8,10,15,19	21	-	1000	30.2	23.5	12.00	12.00	11.15
H2RC036S06	F2RC/F2FC036	5,8,10,15	21	-	1200	34.6	26.2	12.00	12.00	10.85
	F2RP/F2FP036	5,8,10,15,19	21	-	1200	34.6	26.2	12.00	12.00	10.85
	F2RP/F2FP042	5,8,10,15	21	-	1200	34.8	26.3	11.60	11.60	10.70
	F2FP048	5,8,10,15,20,25	24	-	1200	35.4	26.7	12.00	12.00	10.90
H2RC042S06	F2RP/F2FP042	5,8,10,15	21	-	1400	40.5	28.9	11.80	-	10.35
	F2FP048	5,8,10,15,20,25	24	-	1400	42.5	30.5	12.00	-	10.55
H2RC048S06	F2FP048	5,8,10,15,20,25	24	-	1565	46.5	34.9	11.40	11.40	10.75
	F2FP060	5,8,10,15,20,25	24	-	1575	48.0	35.9	11.50	11.50	10.70
	F2FV060	8,10,15,20,25	24	-	1560	48.5	35.9	13.20	13.20	11.70
H3RC060S06	F2FP060	5,8,10,15,20,25	24	-	1600	56.5	37.5	-	12.00	10.25
	F2FV060	8,10,15,20,25	24	-	1780	57.5	42.6	-	12.30	10.60

Rated in accordance with DOE test procedures (Federal Register 12-27-79 and 3-18-88) and ARI Standards 210.

Cooling MBH based on 80°F entering air temperature, 50% RH, and rated air flow.

EER (Energy Efficiency Ratio) is the total cooling output in BTU's at a 95°F outdoor ambient divided by the total electric power in watt-hours at those conditions.

SEER (Seasonal Energy Efficiency Ratio) is the total cooling output in BTU's during a normal annual usage period for cooling divided by the total electric power input in watt-hours during the same period.

- G2FD coils available with a factory installed horizontal drain pan. See price pages for specific model number.
 - Single phase units require single phase 2HK heaters. Three phase units require three phase 2HK heaters.
 - TXV = Thermal Expansion Valve kit required. Use 1TV700 series kit.
 - To meet R=4.2 insulation requirements, substitute F2FP for F2RP, and F2FC for F2RC. models. All ratings remain the same.
 - FG8, FG9, and FL8 furnaces and F2RP / F2RC air handlers have B.O.D (Blower on Delay) standard.
- = Not applicable.

COOLING CAPACITY - Upflow, Downflow & Horizontal Furnaces and Coils

UNIT MODEL	FURNACE**		COIL MODEL	COOLING					
	CFM RANGE (MIN.-MAX.)	W		RATED CFM	NET MBH		SEER + TDR W/O TXV	SEER + TXV ¹ + TDR*	EER
					TOTAL	SENS.			
H2RC018S06	525 675	14,17	G1FA024S14,17	600	19.2	13.0	12.00	12.00	11.35
		-	G1HD024	600	20.0	13.5	12.50	12.50	11.70
		17	G1NA030S17K	600	20.0	13.5	12.75	12.75	11.75
		21	G1NA030S21M	600	20.0	13.5	12.50	12.50	11.75
		14,17	G1UA024S14,17	600	19.2	13.0	12.00	12.00	11.35
		14,17	G2FD024(S,H)14,17	600	19.6	13.2	12.50	12.50	11.60
		17	G2FD030(S,H)17	600	20.0	13.5	12.60	12.60	11.75
H2RC024S06	650 850	14	G1FA036S14	750	23.0	16.4	11.80	11.80	10.70
		14	G1FA030S14	750	23.6	16.9	12.00	12.00	11.00
		14	G1FA036S14	750	24.2	17.6	12.00	12.00	11.25
		17,21	G1FA036S17,21	750	24.0	17.3	12.00	12.00	11.10
		-	G1HD024	750	24.0	17.2	12.00	12.00	11.05
		-	G1HD036	750	24.6	17.6	12.10	12.10	11.35
		17	G1NA030S17K	750	24.0	17.2	12.00	12.00	11.15
		21	G1NA030S21M	750	24.0	17.2	12.00	12.00	11.15
		14,17	G1UA024S14,17	750	23.0	16.4	11.80	11.80	10.70
		14	G1UA030S14	750	23.6	16.9	12.00	12.00	11.00
		14	G1UA036S14	750	24.2	17.6	12.00	12.00	11.25
		17,21	G1UA036S17,21	750	24.0	17.3	12.00	12.00	11.10
		14,17	G2FD024(S,H)14,17	750	23.6	16.9	12.00	12.00	11.00
		17	G2FD030(S,H)17	750	24.0	17.3	12.00	12.00	11.10
		14	G2FD035(S,H)14	750	24.0	17.3	12.10	12.10	11.10
17	G2FD036(S,H)17	750	24.6	17.8	12.15	12.15	11.35		
H2RC030S06	875 1125	14	G1FA030S14	1000	29.2	20.7	11.85	11.85	10.80
		14	G1FA036S14	1000	30.4	21.6	12.00	12.00	11.10
		17,21	G1FA036S17,21	1000	30.0	21.3	12.00	12.00	11.00
		17	G1FA048S17	1000	31.2	22.3	12.50	12.50	11.45
		21	G1FA048S21	1000	31.2	22.3	12.50	12.50	11.35
		-	G1HD036	1000	30.8	21.9	12.75	12.75	11.25
		17	G1NA030S17K	1000	30.2	21.4	12.00	12.00	11.05
		21	G1NA030S21M	1000	30.2	21.4	12.00	12.00	11.05
		17	G1NA036S17L	1000	31.4	22.3	12.50	12.50	11.45
		14	G1UA030S14	1000	29.2	20.7	11.85	11.85	10.80
		14	G1UA036S14	1000	30.4	21.6	12.00	12.00	11.10
		17,21	G1UA036S17,21	1000	30.0	21.3	12.00	12.00	11.00
		17	G1UA048S17	1000	31.2	22.3	12.50	12.50	11.45
		21	G1UA048S21	1000	31.2	22.3	12.50	12.50	11.35
		17	G2FD030(S,H)17	1000	30.0	21.3	12.00	12.00	11.00
		14	G2FD035(S,H)14	1000	30.0	21.3	12.00	12.00	11.00
		17	G2FD036(S,H)17	1000	30.6	21.8	12.25	12.25	11.20
21	G2FD036(S,H)21	1000	30.8	21.9	12.25	12.25	11.25		
21	G2FD042(S,H)21	1000	31.0	22.1	12.50	12.50	11.35		
17	G2FD046(S,H)17	1000	31.4	22.3	12.50	12.50	11.45		
H2RC036S06	1050 1350	14	G1FA036S14	1200	33.6	23.4	11.50	11.50	10.60
		17,21	G1FA036S17,21	1200	33.0	23.0	11.25	11.25	10.45
		17	G1FA048S17	1200	35.0	24.4	12.00	12.00	10.90
		21	G1FA048S21	1200	34.0	25.2	12.00	12.00	10.70
		-	G1HD036	1200	34.0	23.7	11.80	11.80	10.70
		-	G1HD048	1200	35.4	24.7	12.00	12.00	11.00
		17	G1NA036S17L	1200	35.0	24.8	12.00	12.00	10.90
		21	G1NA048S21D	1200	35.0	24.8	12.00	12.00	10.90
		14	G1UA036S14	1200	33.6	23.4	11.50	11.50	10.60
		17,21	G1UA036S17,21	1200	33.0	23.0	11.25	11.25	10.45
		17	G1UA048S17	1200	35.0	24.4	12.00	12.00	10.90
		21	G1UA048S21	1200	34.0	25.2	12.00	12.00	10.70
		21	G1NA048S21D	1200	35.0	25.2	12.00	12.00	10.40
		14	G2FD035(S,H)14	1200	33.0	23.0	11.25	11.25	10.45
		17	G2FD036(S,H)17	1200	33.8	23.6	11.50	11.50	10.70
		21	G2FD036(S,H)21	1200	34.2	23.8	12.50	12.50	10.75
		21	G2FD042(S,H)21	1200	34.6	24.1	12.00	12.00	10.80
17	G2FD046(S,H)17	1200	35.0	24.4	12.00	12.00	10.90		
21,24	G2FD048(S,H)21,24	1200	36.0	25.1	12.10	12.10	11.10		

For Notes See Page 5.

COOLING CAPACITY - Upflow, Downflow & Horizontal Furnaces and Coils (Continued)

UNIT MODEL	FURNACE**		COIL MODEL	RATED CFM	COOLING				
	CFM RANGE (MIN.-MAX.)	W			NET MBH		SEER + TDR W/O TXV	SEER + TXV ¹ + TDR*	EER
					TOTAL	SENS.			
H1RC036S(25,46)	1050 1350	14	G1FA036S14	1235	33.4	25.0	-	11.50	10.65
		17,21	G1FA036S17,21	1235	33.0	24.4	-	11.50	10.55
		21	G1FA048S21	1235	35.0	25.9	-	12.00	10.70
		-	G1HD036	1235	33.4	24.7	-	11.80	10.70
		-	G1HD048	1235	35.0	25.8	-	12.00	11.05
		17	G1NA036S17L	1200	35.0	24.4	-	12.00	10.90
		21	G1NA048S21D	1200	35.0	24.4	-	12.00	10.90
		14	G1UA036S14	1200	33.4	25.0	-	11.50	10.65
		17,21	G1UA036S17,21	1235	33.0	24.4	-	11.50	10.55
		21	G1UA048S21	1235	35.0	25.9	-	12.00	10.70
		14	G2FD035(S,H)14	1200	32.8	24.3	-	11.55	10.55
		17	G2FD036(S,H)17	1250	33.6	24.9	-	12.00	10.65
		21	G2FD036(S,H)21	1200	34.2	25.3	-	12.00	10.90
		21	G2FD042(S,H)21	1235	34.4	25.5	-	12.00	10.90
17	G2FD046(S,H)17	1250	34.8	25.8	-	12.00	10.95		
21,24	G2FD048(S,H)21,24	1250	35.4	26.2	-	12.10	11.15		
H2RC042S06	1225 1575	17	G1FA048S17	1400	42.0	30.2	12.00	-	10.60
		21	G1FA048S21	1400	41.5	29.7	12.00	-	10.65
		21,24	G1FA060S21,24	1400	43.0	30.7	12.50	-	10.95
		-	G1HD048	1400	41.5	29.7	12.00	-	10.60
		21	G1NA048S21D	1400	41.0	28.6	12.00	-	10.40
		17	G1UA048S17	1400	42.0	30.2	12.00	-	10.60
		21	G1UA048S21	1400	41.5	29.7	12.00	-	10.65
		21,24	G1UA060S21,24	1400	43.0	30.7	12.50	-	10.95
		21	G2FD042(S,H)21	1400	41.0	29.3	12.00	-	10.50
		17	G2FD046(S,H)17	1400	42.0	30.2	12.00	-	10.60
21,24	G2FD048(S,H)21,24	1400	42.5	30.6	12.00	-	10.75		
H2RC048S06	1375 1775	17	G1FA048S17	1575	45.5	34.1	12.00	12.00	11.00
		21	G1FA048S21	1575	46.5	34.9	12.00	12.00	11.00
		21,24	G1FA060S21,24	1575	48.0	36.0	12.50	12.50	11.10
		-	G1HD048	1575	46.0	34.5	12.00	12.00	10.80
		-	G1HD060	1575	47.5	35.6	12.40	12.40	11.05
		21	G1NA048S21D	1575	46.0	34.5	12.00	12.00	10.70
		17	G1UA048S17	1575	45.5	34.1	12.00	12.00	11.00
		21	G1UA048S21	1575	46.5	34.9	12.00	12.00	11.00
		21,24	G1UA060S21,24	1575	48.0	36.0	12.50	12.50	11.10
		17	G2FD046(S,H)17	1575	45.5	34.1	12.00	12.00	10.80
		21,24	G2FD048(S,H)21,24	1575	46.5	34.9	12.20	12.20	10.90
		24	G2FD060(S,H)24	1575	48.0	36.0	12.50	12.50	11.10
		24	G2FD061H24	1575	48.5	36.4	12.50	12.50	11.20
H1RC048S(25,46)	1400 1800	17	G1FA048S17	1500	44.5	32.9	-	12.00	10.50
		21	G1FA048S21	1600	45.5	33.7	-	12.00	11.00
		21,24	G1FA060S21,24	1600	47.0	34.8	-	12.50	11.45
		-	G1HD048	1600	45.0	33.3	-	12.00	11.15
		-	G1HD060	1600	46.5	36.1	-	12.40	11.40
		21	G1NA048S21D	1400	46.0	34.0	-	12.00	11.20
		17	G1UA048S17	1500	44.5	32.9	-	12.00	10.50
		21	G1UA048S21	1600	45.5	33.7	-	12.00	11.00
		21,24	G1UA060S21,24	1600	47.0	34.8	-	12.50	11.45
		17	G2FD046(S,H)17	1500	44.5	32.9	-	12.00	10.50
		21,24	G2FD048(S,H)21,24	1600	45.5	33.7	-	12.20	11.20
		24	G2FD060(S,H)24	1600	47.0	34.8	-	12.50	11.45
		24	G2FD061H24	1600	47.5	35.2	-	12.50	11.50
H3RC060S06 H2RC060S(25,46)	1600 2100	21,24	G1FA060S21,24	1800	57.5	42.6	-	12.00	10.40
		-	G1HD060	2000	57.5	42.6	-	12.00	10.25
		24	G1NA060S24T	1850	57.5	38.9	-	12.00*	10.50
		21,24	G1UA060S21,24	1800	57.5	42.6	-	12.00	10.40
		24	G2FD060(S,H)24	1800	57.5	42.6	-	12.00	10.40
24	G2FD061H24	1850	58.0	43.2	-	12.00	10.45		

1. TXV = Use 1TV700 Series Kit.

*Requires 2FD Blower Time Delay unless a standard furnace is equipped with one.

** Refer to Quick Selection Chart for specific furnace match-up.

COOLING CAPACITY - With Variable Speed Furnaces

UNIT MODEL	VARIABLE SPEED FURNACE MODEL	COIL MODEL ¹	W	COOLING					
				RATED CFM	NET MBH		SEER W/O TXV	SEER + TXV ²	EER
					TOTAL	SENS.			
1 PH 12 SEER AC - VARIABLE SPEED³									
H2RC018S06	P1DUA12V	G1FA024S14	14	600	19.6	13.4	-	13.00	12.55
	P1DUA12V	G2FD024(S,H)14	14	600	20.0	13.6	-	14.00	12.90
	P1XDB12V	G2FD024(S,H)17	17	620	20.2	14.0	-	13.75	12.90
	P1XUB12V	G1FA024S17	17	620	19.6	13.4	-	13.00	12.45
H2RC024S06	P1XUB12V	G2FD024(S,H)17	17	620	20.0	13.6	-	13.75	12.80
	P1DUA12V	G1FA024S14	14	750	23.4	16.8	-	13.00	11.60
	P1DUA12V	G2FD024(S,H)14	14	750	24.0	17.3	-	13.00	12.05
	P1XDB12V	G2FD024(S,H)17	17	815	24.2	17.5	-	12.50	11.85
	P1XUB12V	G1FA024S17	17	730	23.6	17.0	-	13.00	11.80
H2RC030S06	P1XUB12V	G2FD024(S,H)17	17	730	24.2	17.5	-	13.00	12.10
	P1DUA12V	G1FA030S14	14	975	29.6	21.1	-	12.50	11.55
	P1DUA12V	G2FD035(S,H)14	14	975	30.4	21.7	-	13.00	11.80
	P1DUB16V	G1FA036S17	17	1050	30.6	21.9	-	13.00	11.95
	P1DUB16V	G2FD030(S,H)17	17	1050	30.6	21.9	-	13.00	11.95
	P1XDB12V	G2FD030(S,H)17	17	1050	30.6	21.9	-	12.50	11.60
	P1XUB12V	G1FA036S17	17	1020	30.4	21.7	-	12.75	11.70
	P1XUB12V	G2FD030(S,H)17	17	1020	30.4	21.7	-	12.75	11.70
H2RC036S06	P1XUC16V	G1FA036S21	21	1000	30.6	21.9	-	13.00	12.00
	P1XUC16V	G2FD036(S,H)21	21	1000	31.4	22.5	-	13.00	12.30
	P1DUA12V	G1FA036S14	14	1185	33.8	23.6	-	12.00	10.95
	P1DUA12V	G2FD035(S,H)14	14	1185	33.2	23.2	-	11.50	10.80
	P1DUB16V	G1FA036S17	17	1200	33.4	23.4	-	12.00	11.15
	P1DUB16V	G2FD036(S,H)17	17	1200	34.4	24.2	-	12.25	11.40
	P1DUC20V	G1FA036S21	21	1200	33.6	23.6	-	12.00	11.30
	P1DUC20V	G2FD036(S,H)21	21	1200	34.8	24.4	-	13.00	11.60
	P1XDB12V	G2FD036(S,H)17	17	1130	34.4	24.4	-	12.00	11.15
	P1XUB12V	G1FA036S17	17	1220	33.2	23.2	-	11.50	10.80
	P1XUB12V	G2FD036(S,H)17	17	1200	34.0	23.8	-	12.00	11.05
	P1XUC16V	G1FA036S21	21	1200	33.4	23.4	-	12.00	11.15
	P1XUC16V	G2FD036(S,H)21	21	1200	34.8	24.4	-	12.75	11.45
	P1XUC20V	G1FA048S21	21	1200	34.6	25.8	-	13.00	11.60
P1XUC20V	G2FD042(S,H)21	21	1200	35.2	24.7	-	13.00	11.65	
P1XUD20V	G2FD048(S,H)24	24	1260	36.4	25.5	-	12.75	11.65	
H1RC036S(25,46)	P1DUA12V	G1FA036S14	14	1185	33.6	25.2	-	12.00	11.05
	P1DUA12V	G2FD035(S,H)14	14	1185	33.0	24.5	-	12.00	10.90
	P1DUB16V	G1FA036S17	17	1250	33.4	24.8	-	12.00	11.15
	P1DUB16V	G2FD036(S,H)17	17	1250	34.0	25.3	-	12.50	11.30
	P1DUC20V	G1FA036S21	21	1200	33.6	25.0	-	12.25	11.45
	P1DUC20V	G2FD036(S,H)21	21	1200	34.8	25.9	-	13.00	11.75
	P1XUB12V	G1FA036S17	17	1220	33.2	24.6	-	12.00	10.95
	P1XUB12V	G2FD036(S,H)17	17	1200	34.0	25.3	-	12.25	11.10
	P1XUC16V	G1FA036S21	21	1260	33.4	24.8	-	12.00	11.15
	P1XUC16V	G2FD036(S,H)21	21	1200	34.8	25.9	-	12.75	11.60
	P1XUC20V	G1FA048S21	21	1260	35.6	26.5	-	13.00	11.50
	P1XUC20V	G2FD042(S,H)21	21	1260	35.0	26.1	-	12.75	11.65
	P1XUD20V	G2FD048(S,H)24	24	1260	35.8	26.6	-	13.00	11.85
	H2RC042S06	P1DUB16V	G1FA048S17	17	1400	42.5	30.7	-	12.50
P1DUC20V		G1FA048S21	21	1400	42.0	30.2	-	12.50	11.15
P1XDD20V		G2FD048(S,H)24	24	1365	43.0	31.1	-	12.80	11.35
P1XUC16V		G1FA048S21	21	1400	42.0	30.2	-	12.50	11.10
P1XUD20V		G1FA060S24	24	1430	43.5	31.2	-	13.00	11.35
P1XUD20V		G2FD048(S,H)24	24	1430	43.0	31.1	-	12.25	11.05

For Notes See Page 7.

COOLING CAPACITY - With Variable Speed Furnaces

UNIT MODEL	VARIABLE SPEED FURNACE MODEL	COIL MODEL ¹	W	COOLING					
				RATED CFM	NET MBH		SEER W/O TXV	SEER + TXV ²	EER
					TOTAL	SENS.			
H2RC048S06	P1DUC20V	G1FA048S21	21	1610	46.5	34.9	-	12.10	11.15
	P1DUC20V	G2FD048(S,H)21	21	1610	46.5	34.9	-	12.25	11.05
	P1XDD20V	G2FD048(S,H)24	24	1610	47.0	35.4	-	12.40	11.00
	P1XUC16V	G1FA048S21	21	1480	46.0	34.4	-	12.10	10.90
	P1XUC16V	G2FD048(S,H)21	21	1480	46.0	34.4	-	12.30	10.80
	P1XUC20V	G1FA048S21	21	1590	46.5	34.9	-	12.10	11.10
	P1XUC20V	G2FD048(S,H)21	21	1590	46.5	34.9	-	12.25	11.00
	P1XUD20V	G1FA060S24	24	1560	48.5	36.5	-	13.00	11.45
	P1XUD20V	G2FD048(S,H)24	24	1560	47.0	35.4	-	12.50	11.20
H1RC048S(25,46)	P1DUC20V	G1FA048S21	21	1610	45.5	33.7	-	12.20	11.20
	P1DUC20V	G2FD048(S,H)21	21	1610	45.5	33.7	-	12.25	11.40
	P1XUC16V	G1FA048S21	21	1480	45.0	33.2	-	12.20	10.95
	P1XUC16V	G2FD048(S,H)21	21	1480	45.0	33.2	-	12.30	11.10
	P1XUC20V	G1FA048S21	21	1590	45.5	33.7	-	12.10	11.15
	P1XUC20V	G2FD048(S,H)21	21	1590	45.5	33.7	-	12.25	11.35
	P1XUD20V	G1FA060S24	24	1620	47.0	34.8	-	12.75	11.65
	P1XUD20V	G2FD048(S,H)24	24	1620	45.5	33.7	-	12.25	11.30
	P1XUD20V	G2FD060(S,H)24	24	1620	47.0	34.8	-	12.75	11.65
H3RC060S06 H1RC060S(25,46)	P1XDD20V	G2FD060(S,H)24	24	1805	57.0	42.6	-	11.50	10.00
	P1XUC20V	G1FA060S21	21	1620	57.0	42.1	-	12.10	10.20
	P1XUD20V	G1FA060S24	24	1620	57.0	42.1	-	12.10	10.40
	P1XUD20V	G2FD060(S,H)24	24	1620	57.0	42.1	-	12.10	10.40
	P1XUD20V	G2FD061H24	24	1800	58.0	43.2	-	12.10	10.55

- G2FD coils available with a factory installed horizontal drain pan. See price pages for specific model number.
- TXV = Use 1TV700 Series Kit.
- Variable speed furnaces have B.O.D (Blower on Delay) standard.

COOLING PERFORMANCE

MODEL	SUCT. T/P @ COMPR.		AIR TEMP ON CONDENSER						MODEL	SUCT. T/P @ COMPR.		AIR TEMP ON CONDENSER					
			75°F		95°F		115°F					75°F		95°F		115°F	
	TEMP.	PSIG	MBH	KW	MBH	KW	MBH	KW		TEMP.	PSIG	MBH	KW	MBH	KW	MBH	KW
H2RC018S06	35	61.5	17.19	1.44	13.89	1.59	11.63	1.70	H2RC042S06	35	61.5	35.94	3.12	31.92	3.76	27.86	4.54
	40	68.5	18.77	1.45	15.80	1.63	13.53	1.77		40	68.5	39.29	3.15	35.11	3.77	30.80	4.55
	45	76.0	20.48	1.47	17.70	1.66	15.04	1.83		45	76.0	42.48	3.21	38.17	3.84	33.70	4.63
	50	84.0	21.99	1.48	19.60	1.70	16.81	1.89		50	84.0	45.62	3.23	41.40	3.92	36.56	4.39
H2RC024S06	35	61.5	20.81	1.81	16.82	2.00	14.07	2.14	H2RC048S06	35	61.5	40.62	3.39	36.09	4.08	31.50	4.91
	40	68.5	22.73	1.83	19.13	2.05	16.37	2.23		40	68.5	44.42	3.41	39.69	4.09	34.83	4.94
	45	76.0	24.80	1.85	21.43	2.09	18.20	2.31		45	76.0	48.02	3.47	43.16	4.16	38.10	5.02
	50	84.0	26.63	1.86	23.73	2.14	20.36	2.37		50	84.0	51.58	3.50	46.81	4.25	41.33	4.76
H2RC030S06	35	61.5	26.48	2.34	21.42	2.59	17.91	2.77	H1RC048S(25,46)	35	61.5	39.75	3.32	35.31	3.99	30.82	4.81
	40	68.5	28.94	2.36	24.34	2.65	20.84	2.92		40	68.5	43.46	3.34	38.84	4.00	34.08	4.83
	45	76.0	31.56	2.39	27.07	2.71	23.17	2.96		45	76.0	46.99	3.40	42.23	4.07	37.28	4.91
	50	84.0	33.89	2.40	30.20	2.77	25.92	3.07		50	84.0	50.47	3.43	45.80	4.16	40.44	4.66
H2RC036S06	35	61.5	29.38	2.76	23.75	3.06	19.87	3.26	H3RC060S06 H1RC060S(25,46)	35	61.5	50.26	4.42	44.64	5.32	38.97	6.42
	40	68.5	32.09	2.78	27.00	3.13	23.12	3.40		40	68.5	54.95	4.46	49.10	5.33	43.08	6.44
	45	76.0	35.01	2.81	30.25	3.19	25.70	3.51		45	76.0	59.41	4.54	53.38	5.43	47.13	6.55
	50	84.0	37.59	2.83	33.50	3.26	28.74	3.62		50	84.0	63.81	4.58	57.90	5.55	51.13	6.22
H1RC036S(25,46)	35	61.5	29.20	2.70	23.61	2.99	19.75	3.19									
	40	68.5	31.90	2.72	26.84	3.06	22.98	3.32									
	45	76.0	34.80	2.75	30.07	3.12	25.54	3.43									
	50	84.0	37.36	2.77	33.30	3.19	28.57	3.54									

- For condensing unit only. Does not include effect of evaporator motor power or heat.
- Performance based on 15° superheat and 15° sub-cooling at condensing unit.
 - Increase capacity 1% for each 2° increase in sub-cooling.
 - Decrease capacity 1% for each 2° decrease in sub-cooling.
- Sub-cooling in excess of 20° may result in excessively high condensing temperature with air on condenser above 115°. Maximum recommended condensing temperature is 140°F.

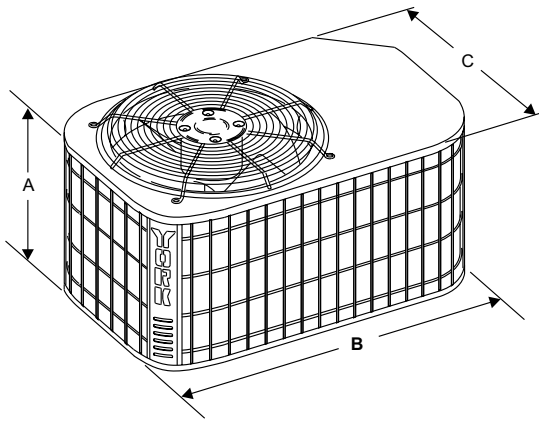

All dimensions are in inches. They are subject to change without notice. Certified dimensions will be provided upon request.

DIMENSIONS - 1 Phase

UNIT MODEL	DIMENSIONS (INCHES)			REFRIGERANT CONNECTION LINE SIZE	
	A ¹	B	C	Liquid	Vapor
018	25	35	23	3/8"	3/4
024	25	35	23		
030	27	37	27		
036	27	37	27		7/8
042	29	37	27		
048	33	37	27		
060	39	37	27		

1. Included Fan Guard

DIMENSIONS - 3 Phase

Unit Model	Dimensions (Inches)			Refrigerant Connection Line Size	
	A ¹	B	C	Liquid	Vapor
036	27	37	27	3/8"	3/4
048	29	37	27	3/8"	7/8
060	39	37	27	3/8"	1-1/8*

1. Included Fan Guard

* Reducer Required

ACCESSORIES*

Refer to Price Manual for specific model numbers.

Hard Start Kit - Provides increased starting torque for areas with low voltage.

Compressor Blanket - Designed to further reduce the normal compressor operating sound. Refer to price pages for specific match-ups.

Off Cycle Timer Delay - Provides a 5-minute off cycle to prevent rapid recycling of the compressor.

Room Thermostats - A wide selection of compatible thermostats are available to provide optimum performance and features for any installation.

1 Heat Stage only, manual, mechanical thermostat. Add sub-base for 1H/1C.

1H/1C, manual change-over electronic non-programmable thermostat.

1H/1C, auto/manual changeover, electronic programmable, deluxe 7-day, thermostat.

1H/1C, auto/manual changeover, electronic programmable.

* For the most current accessory information, refer to the price book or consult factory.

SOUND RATINGS*

UNIT MODEL	SOUND RATINGS DECIBELS
018	75
024	80
030	76
036	79
042	78
048	80
060	79

*Rated in accordance with ARI Standard 270.

TYPICAL INSTALLATION

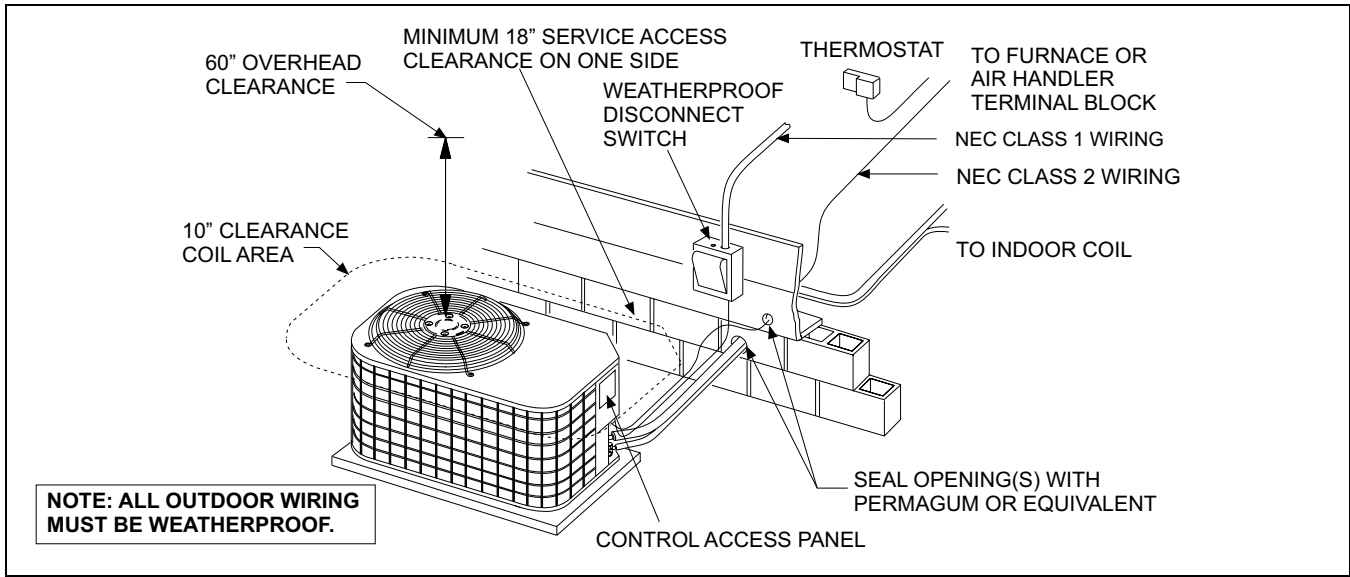

TYPICAL FIELD WIRING - 1 Phase Application

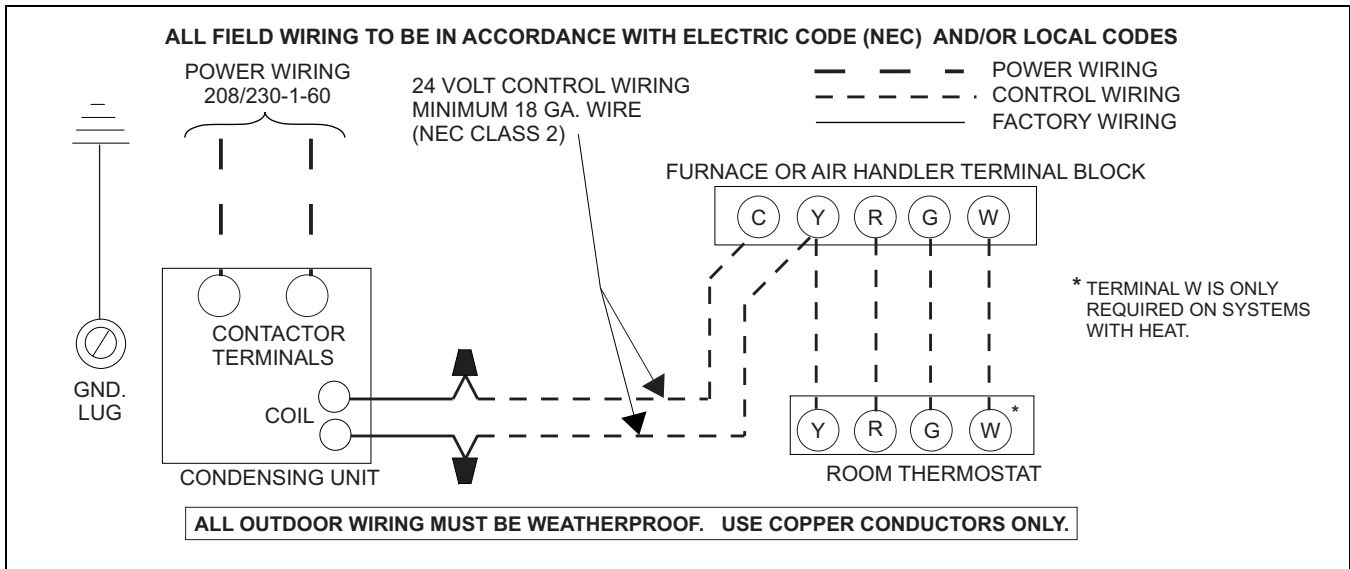

TYPICAL FIELD WIRING - 3 Phase Application

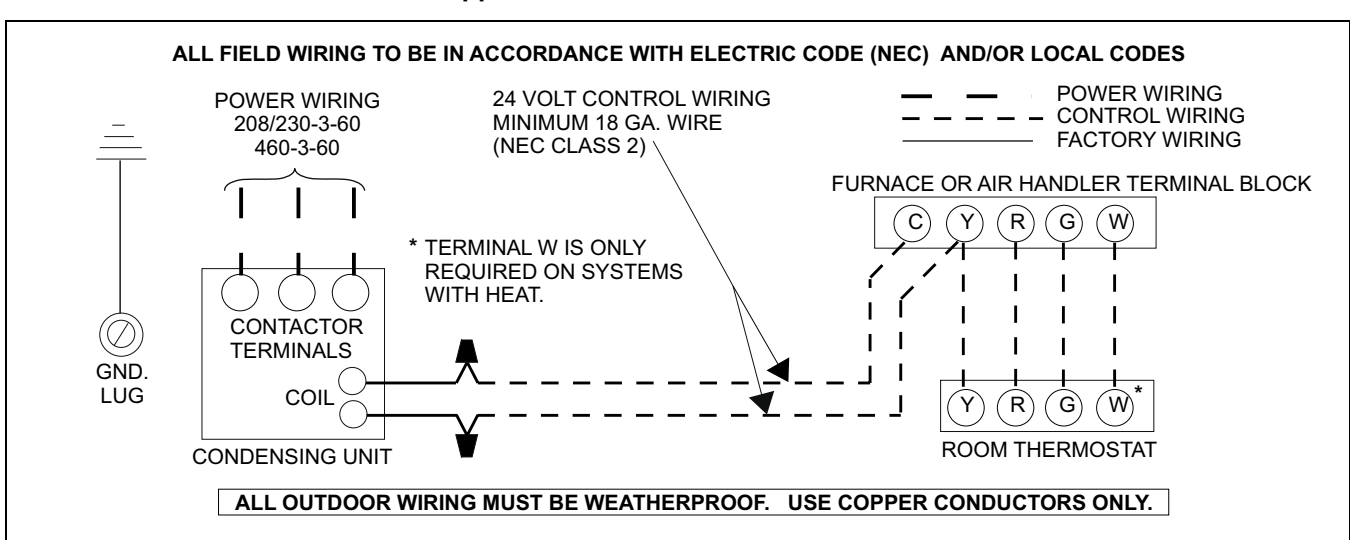

COOLING PERFORMANCE DATA										
AIR CONDITIONER MODEL NO.		H2RC018S06								
INDOOR COIL MODEL NO.		G1FA024S14,17								
CONDENSING ENTERING AIR TEMPERATURE	IDCFM	500			650			800		
	ID DB (°F)	85	80	75	85	80	75	85	80	75
	ID WB (°F)	72	67	63	72	67	63	72	67	63
75	T.C.	20.1	19.3	18.2	20.1	19.4	18.6	20.1	19.5	18.9
	S.C.	11.7	11.5	11.3	12.1	12.2	12.2	12.5	12.8	13.1
	KW	1.26	1.25	1.25	1.27	1.26	1.26	1.27	1.26	1.26
85	T.C.	19.8	18.7	17.0	20.0	19.1	17.7	20.3	19.5	18.3
	S.C.	11.7	11.4	10.9	12.7	12.5	12.1	13.6	13.5	13.4
	KW	1.37	1.35	1.34	1.37	1.36	1.35	1.38	1.37	1.36
95	T.C.	19.5	18.1	15.8	20.0	19.2	16.7	20.5	19.5	17.7
	S.C.	11.7	11.3	10.4	13.2	13.0	12.0	14.7	14.2	13.6
	KW	1.47	1.45	1.43	1.48	1.47	1.45	1.49	1.48	1.46
105	T.C.	18.1	16.3	14.2	18.7	17.1	15.0	19.4	17.8	15.8
	S.C.	11.3	10.6	9.7	13.0	12.2	11.3	14.7	13.8	12.9
	KW	1.58	1.55	1.52	1.59	1.57	2.53	1.61	1.58	3.54
115	T.C.	16.6	14.5	12.7	17.5	15.3	13.2	18.3	16.1	13.8
	S.C.	10.8	9.8	9.1	12.7	11.6	10.6	14.7	13.4	12.1
	KW	1.69	1.65	1.61	1.71	1.67	3.62	1.73	1.69	5.62
125	T.C.	15.2	12.7	11.1	16.2	13.6	11.5	17.3	14.5	11.9
	S.C.	10.4	9.1	8.4	12.5	11.1	9.9	14.6	13.0	11.4
	KW	1.79	1.75	1.70	1.82	1.77	4.70	1.85	1.79	7.70

NOTE: ALL CAPACITIES ARE NET WITH INDOOR FAN HEAT ALREADY DEDUCTED AT 1250 BTUH/1000 CFM.

Multipliers for determining the performance with other indoor sections.

NOTE: For dry bulb temperatures different than those listed (between 73-87 F), sensible capacity increases by 1060 BTUH per 1000 CFM per degree above the listed temperature and decreases by 1060 BTUH per 1000 CFM per degree below the listed temperature.

Air Handler	Coil	T.C.	S.C.	KW
F2RC/F2FC024		1.04	1.17	1.01
F2RP/F2FP024		1.04	1.04	1.01
N1AHB0806	G2FD024(S,H)14,17	1.02	1.02	1.00
N1VSB12	G2FD024(S,H)17	1.05	1.21	0.93
	G1HD024	1.04	1.04	1.01
	G1NA030S17K	1.04	1.04	1.01
	G1NA030S21M	1.04	1.17	1.01
	G1UA024S14,17	1.00	1.00	1.00
	G2FD024(S,H)14,17	1.02	1.02	1.00
	G2FD030(S,H)17	1.04	1.04	1.01
	G2FD035(S,H)17	1.04	1.04	1.01

Variable Speed Furnace	Coil	T.C.	S.C.	KW
P1DUA12V	G1FA024S14	1.02	1.03	0.92
P1DUA12V	G2FD024(S,H)14	1.04	1.05	0.92
P1XDB12V	G2FD024(S,H)17	1.05	1.07	0.93
P1XUB12V	G1FA024S17	1.02	1.03	0.93
P1XUB12V	G2FD024(S,H)17	1.04	1.05	0.92

COOLING PERFORMANCE DATA										
AIR CONDITIONER MODEL NO.		H2RC024S06								
INDOOR COIL MODEL NO.		G1FA036S17,21								
CONDENSING ENTERING AIR TEMPERATURE	IDCFM	600			800			1000		
	ID DB (°F)	85	80	75	85	80	75	85	80	75
	ID WB (°F)	72	67	63	72	67	63	72	67	63
75	T.C.	25.4	24.2	22.5	25.6	24.5	23.2	25.8	24.9	23.9
	S.C.	14.6	14.6	13.8	15.4	15.6	15.4	16.3	16.6	17.1
	KW	1.61	1.60	1.59	1.61	1.60	1.59	1.62	1.61	1.60
85	T.C.	24.9	23.6	21.4	25.1	23.9	22.2	25.3	24.2	23.0
	S.C.	14.8	14.7	13.8	15.9	16.1	15.6	17.0	17.5	17.5
	KW	1.75	1.74	1.71	1.76	1.75	1.73	1.78	1.76	1.74
95	T.C.	24.4	23.0	20.3	24.6	23.2	21.2	24.8	23.5	22.2
	S.C.	14.9	14.7	13.7	16.3	16.6	15.8	17.7	18.4	17.9
	KW	1.90	1.88	1.84	1.92	1.89	1.86	1.93	1.90	1.88
105	T.C.	22.9	20.8	18.2	23.3	21.4	19.1	23.8	22.0	20.0
	S.C.	14.5	13.8	12.9	16.3	16.0	15.0	18.1	18.1	17.2
	KW	2.04	2.01	1.96	2.07	2.02	1.98	2.09	2.04	2.00
115	T.C.	21.3	18.6	16.2	22.0	19.5	17.0	22.8	20.5	17.7
	S.C.	14.0	12.9	12.0	16.3	15.3	14.2	18.6	17.8	16.4
	KW	2.19	2.13	2.08	2.22	2.16	2.10	2.25	2.18	2.12
125	T.C.	19.8	16.4	14.2	20.7	17.6	14.9	21.8	19.0	15.4
	S.C.	13.5	12.0	11.1	16.3	14.6	13.4	19.1	17.5	15.6
	KW	2.34	2.25	2.20	2.37	2.30	2.22	2.41	2.32	2.24

NOTE: ALL CAPACITIES ARE NET WITH INDOOR FAN HEAT ALREADY DEDUCTED AT 1250 BTUH/1000 CFM.

Multipliers for determining the performance with other indoor sections.

NOTE: For dry bulb temperatures different than those listed (between 73-87 F), sensible capacity increases by 1060 BTUH per 1000 CFM per degree above the listed temperature and decreases by 1060 BTUH per 1000 CFM per degree below the listed temperature.

Air Handler	Coil	T.C.	S.C.	KW
F2RP/F2FP024		0.99	1.01	1.00
F2RP/F2FP030		1.00	1.03	1.00
F2RC/F2FC024		0.98	1.01	1.00
F2RC/F2FC030		0.98	1.01	0.99
N1AHB0806	G2FD024(S,H)17	0.99	0.98	0.99
N1AHB0806	G2FD030(S,H)17	1.00	1.00	1.00
N1VSB12	G2FD024(S,H)17	0.99	1.05	0.92
N1VSB12	G2FD036(S,H)17	1.05	1.17	0.94
	G1FA024S14,17	0.96	0.95	1.00
	G1FA030S14	0.99	0.98	0.99
	G1FA036S14	1.01	1.02	1.00
	G1HD024	1.00	0.99	1.01
	G1HD036	1.03	1.04	1.00
	G1NA030S17K	1.00	1.00	1.00
	G1NA030S21M	1.00	1.00	1.00
	G1UA024S14,17	0.96	0.95	1.00
	G1UA030S14	0.99	0.98	0.99
	G1UA036S14	1.01	1.02	1.00
	G1UA036S17,21	1.00	1.00	1.00
	G2FD024(S,H)14,17	0.99	0.98	0.99
	G2FD030(S,H)17	1.00	1.00	1.00
	G2FD035(S,H)14	1.00	1.00	1.00
	G2FD036(S,H)17	1.03	1.03	1.00

Variable Speed Furnace	Coil	T.C.	S.C.	KW
P1DUA12V	G1FA024S14	0.98	0.97	0.93
P1DUA12V	G2FD024(S,H)14	1.00	1.00	0.92
P1XDB12V	G2FD024(S,H)17	1.01	1.01	0.94
P1XUB12V	G1FA024S17	0.98	0.98	0.93
P1XUB12V	G2FD024(S,H)17	1.01	1.01	0.93

COOLING PERFORMANCE DATA										
AIR CONDITIONER MODEL NO.		H2RC030S06								
INDOOR COIL MODEL NO.		G1FA036S17,21								
CONDENSING ENTERING AIR TEMPERATURE	IDCFM	800			1000			1200		
	ID DB (°F)	85	80	75	85	80	75	85	80	75
	ID WB (°F)	72	67	63	72	67	63	72	67	63
75	T.C.	31.9	30.6	28.9	27.4	30.9	29.4	23.0	31.2	29.9
	S.C.	18.9	19.1	18.9	19.7	20.1	20.3	20.5	21.2	21.8
	KW	1.97	1.95	1.94	1.98	1.96	1.95	1.98	1.97	1.95
85	T.C.	31.4	29.3	27.0	28.2	30.1	28.9	25.0	30.6	30.9
	S.C.	19.2	18.9	18.1	20.1	20.7	20.2	21.1	22.0	22.4
	KW	2.16	2.13	2.09	2.15	2.15	2.13	2.14	2.16	2.16
95	T.C.	30.9	28.1	25.0	29.0	29.2	28.4	27.1	30.1	31.9
	S.C.	19.5	18.7	17.3	20.6	20.7	20.1	21.6	22.8	22.9
	KW	2.35	2.30	2.24	2.32	2.34	2.31	2.29	2.34	2.37
105	T.C.	28.6	25.5	22.3	28.2	26.8	24.6	27.9	27.8	26.8
	S.C.	18.7	17.7	16.2	20.4	20.1	18.7	22.2	22.1	21.2
	KW	2.53	2.45	2.40	2.53	2.49	2.44	2.53	2.51	2.48
115	T.C.	26.3	23.0	19.7	27.5	24.2	20.7	28.6	25.5	21.8
	S.C.	17.9	16.7	15.2	20.3	19.0	17.3	22.8	21.3	19.5
	KW	2.70	2.61	2.55	2.74	2.64	2.57	2.77	2.68	2.59
125	T.C.	24.0	20.4	17.0	26.7	21.7	16.8	29.4	23.2	16.7
	S.C.	17.1	15.6	14.1	20.2	17.9	16.0	23.3	20.5	17.8
	KW	2.88	2.76	2.70	2.94	2.79	2.70	3.00	2.84	2.69

NOTE: ALL CAPACITIES ARE NET WITH INDOOR FAN HEAT ALREADY DEDUCTED AT 1250 BTUH/1000 CFM.

Multipliers for determining the performance with other indoor sections.

NOTE: For dry bulb temperatures different than those listed (between 73-87 F), sensible capacity increases by 1060 BTUH per 1000 CFM per degree above the listed temperature and decreases by 1060 BTUH per 1000 CFM per degree below the listed temperature.

Air Handler	Coil	T.C.	S.C.	KW
F2RP/F2FP030		1.01	1.08	0.99
F2RP/F2FP036		1.03	1.10	1.01
F2RC/F2FC030		0.99	1.01	0.99
F2RC/F2FC036		1.03	1.05	1.01
N1AHB1206	G2FD030(S,H)17	1.00	1.00	1.00
N1AHB1206	G2FD036(S,H)17	1.02	1.03	1.00
N1VSB12	G2FD036(S,H)17	1.03	1.12	0.94
N1VSB12	G2FD046(S,H)17	1.07	1.15	0.95
	G1FA030S14	0.97	0.98	0.99
	G1FA036S14	1.01	1.02	1.00
	G1FA048S17	1.04	1.05	1.00
	G1FA048S21	1.04	0.99	1.01
	G1HD036	1.03	1.03	1.00
	G1NA036S17L	1.05	1.05	1.01
	G1NA030S17K	1.01	1.01	1.00
	G1NA030S21M	1.01	1.01	1.00
	G1UA030S14	0.97	0.98	0.99
	G1UA036S14	1.01	1.02	1.00
	G1UA036S17,21	1.00	1.00	1.00
	G1UA048S17	1.04	1.05	1.00
	G1UA048S21	1.04	0.99	1.01
	G2FD030(S,H)17	1.00	1.00	1.00
	G2FD035(S,H)14	1.00	1.00	1.00
	G2FD036(S,H)17	1.02	1.03	1.00
	G2FD036(S,H)21	1.03	1.03	1.00
	G2FD042(S,H)21	1.03	1.04	1.00
	G2FD046(S,H)17	1.05	1.05	1.01

Variable Speed Furnace	Coil	T.C.	S.C.	KW
P1DUA12V	G1FA030S14	0.99	0.99	0.94
P1DUA12V	G2FD035(S,H)14	1.01	1.02	0.94
P1DUB16V	G1FA036S17	1.02	1.03	0.94
P1DUB16V	G2FD030(S,H)17	1.02	1.03	0.94
P1XDB12V	G2FD030(S,H)17	1.02	1.03	0.97
P1XUB12V	G1FA036S17	1.01	1.02	0.95
P1XUB12V	G2FD030(S,H)17	1.01	1.02	0.95
P1XUC16V	G1FA036S21	1.02	1.03	0.94
P1XUC16V	G2FD036(S,H)21	1.05	1.06	0.94

COOLING PERFORMANCE DATA										
AIR CONDITIONER MODEL NO.		H2RC036S06								
INDOOR COIL MODEL NO.		G1FA048S21								
CONDENSING ENTERING AIR TEMPERATURE	IDCFM	1000			1200			1400		
	ID DB (°F)	85	80	75	85	80	75	85	80	75
	ID WB (°F)	72	67	63	72	67	63	72	67	63
75	T.C.	36.7	34.3	32.3	36.9	34.9	32.8	37.2	35.4	33.2
	S.C.	23.2	22.8	22.5	24.3	24.2	23.9	25.4	25.6	25.4
	KW	2.31	2.30	2.27	2.33	2.30	2.28	2.34	2.31	2.30
85	T.C.	35.3	33.1	30.9	35.7	33.7	31.4	36.2	34.2	31.9
	S.C.	23.2	22.6	21.9	24.8	24.3	23.6	26.3	26.0	25.3
	KW	2.51	2.48	2.45	2.53	2.50	2.47	2.54	2.51	2.48
95	T.C.	34.0	31.9	29.6	34.5	33.6	30.0	35.1	33.0	30.5
	S.C.	23.3	22.4	21.3	25.3	23.4	23.3	27.3	26.4	25.2
	KW	2.71	2.67	2.64	2.73	2.73	2.66	2.74	2.71	2.67
105	T.C.	31.8	29.5	27.2	32.3	30.0	27.6	32.9	30.5	28.0
	S.C.	22.6	21.6	20.5	24.8	23.7	22.5	26.9	25.8	24.5
	KW	2.93	2.88	2.82	2.94	2.90	2.85	2.96	2.92	2.87
115	T.C.	29.6	27.2	24.8	30.1	27.6	25.1	30.6	28.0	25.4
	S.C.	22.0	20.8	19.7	24.3	23.0	21.8	26.6	25.2	23.9
	KW	3.15	3.09	3.01	3.16	3.11	3.04	3.18	3.13	3.07
125	T.C.	27.3	24.8	22.4	27.8	25.2	22.6	28.4	25.5	22.9
	S.C.	21.4	20.0	19.0	23.8	22.3	21.1	26.2	24.6	23.2
	KW	3.36	3.29	3.19	3.38	3.31	3.23	3.39	3.33	3.26

NOTE: ALL CAPACITIES ARE NET WITH INDOOR FAN HEAT ALREADY DEDUCTED AT 1250 BTUH/1000 CFM.

Multipliers for determining the performance with other indoor sections.

NOTE: For dry bulb temperatures different than those listed (between 73-87 F), sensible capacity increases by 1060 BTUH per 1000 CFM per degree above the listed temperature and decreases by 1060 BTUH per 1000 CFM per degree below the listed temperature.

Air Handler	Coil	T.C.	S.C.	KW
F2RC/F2FC036		1.02	1.04	1.00
F2RP/F2FP036		1.02	1.03	1.00
F2RP/F2FP042		1.02	1.04	1.02
F2FP048		1.04	1.06	1.02
N1VSB12	G2FD036(S,H)17	1.02	1.03	0.96
N1VSB12	G2FD046(S,H)17	1.05	1.08	0.97
N1VSC16	G2FD048(S,H)21	1.08	1.11	0.95
N1AHB1206	G2FD036(S,H)17	0.99	0.94	0.99
N1AHB1206	G2FD046(S,H)17	1.03	0.97	1.01
	G1FA036S17,21	0.97	0.91	0.99
	G1FA036S14	0.99	0.93	1.00
	G1FA048S17	1.03	0.97	1.01
	G1HD036	1.00	0.94	1.00
	G1HD048	1.04	0.98	1.01
	G1NA048S21D	1.03	0.99	1.01
	G1NA036S17L	1.03	0.99	1.01
	G1UA036S17,21	0.97	0.91	0.99
	G1UA036S14	0.99	0.93	1.00
	G1UA048S17	1.03	0.97	1.01
	G1UA048S21	1.00	1.00	1.00
	G2FD035(S,H)14	0.97	0.91	0.99
	G2FD036(S,H)17	0.99	0.94	0.99
	G2FD036(S,H)21	1.01	0.95	1.00
	G2FD042(S,H)21	1.02	0.96	1.01
	G2FD046(S,H)17	1.03	0.97	1.01
	G2FD048(S,H)21,24	1.06	1.00	1.02

Variable Speed Furnace	Coil	T.C.	S.C.	KW
P1DUA12V	G1FA036S14	0.99	0.94	0.97
P1DUA12V	G2FD035(S,H)14	0.98	0.92	0.97
P1DUB16V	G1FA036S17	0.98	0.93	0.94
P1DUB16V	G2FD036(S,H)17	1.01	0.96	0.95
P1DUC20V	G1FA036S21	0.99	0.94	0.94
P1DUC20V	G2FD036(S,H)21	1.02	0.97	0.94
P1XDB12V	G2FD036(S,H)17	1.01	0.97	0.97
P1XUB12V	G1FA036S17	0.98	0.92	0.97
P1XUB12V	G2FD036(S,H)17	1.00	0.94	0.97
P1XUC16V	G1FA036S21	0.98	0.93	0.94
P1XUC16V	G2FD036(S,H)21	1.02	0.97	0.96
P1XUC20V	G1FA048S21	1.02	1.02	0.94
P1XUC20V	G2FD042(S,H)21	1.04	0.98	0.95
P1XUD20V	G2FD048(S,H)24	1.07	1.01	0.98

COOLING PERFORMANCE DATA										
AIR CONDITIONER MODEL NO.		H1RC036S(25,46)								
INDOOR COIL MODEL NO.		G1FA048S21								
CONDENSING ENTERING AIR TEMPERATURE	IDCFM	1000			1200			1400		
	ID DB (°F)	85	80	75	85	80	75	85	80	75
	ID WB (°F)	72	67	63	72	67	63	72	67	63
75	T.C.	39.7	37.5	36.7	39.0	37.7	36.8	39.0	37.6	36.8
	S.C.	23.9	23.8	25.0	23.5	24.3	25.3	24.0	25.1	25.6
	KW	2.97	2.94	2.91	2.97	2.95	2.91	2.96	2.94	2.92
85	T.C.	38.3	36.1	34.4	37.9	36.3	34.6	38.0	36.4	34.9
	S.C.	24.0	23.7	24.0	24.1	24.5	24.7	24.7	25.3	25.2
	KW	3.23	3.18	3.13	3.23	3.20	3.14	3.23	3.20	3.15
95	T.C.	36.9	34.6	32.2	36.9	34.9	32.6	37.0	35.2	33.0
	S.C.	24.2	23.7	22.9	24.7	24.6	23.9	25.3	25.5	24.8
	KW	3.49	3.43	3.34	3.50	3.44	3.36	3.50	3.46	3.37
105	T.C.	35.5	33.2	30.0	35.8	33.6	30.4	36.0	34.0	31.0
	S.C.	24.3	23.6	21.9	25.4	24.9	23.6	26.0	25.6	24.4
	KW	3.75	3.67	3.56	3.76	3.69	3.58	3.77	3.72	3.59
115	T.C.	33.2	30.4	26.7	33.4	30.8	27.2	33.6	31.3	27.7
	S.C.	23.7	22.5	20.7	24.5	23.6	21.9	25.4	24.6	23.0
	KW	4.01	3.88	3.75	4.02	3.91	3.77	4.03	3.93	3.78
125	T.C.	31.0	27.6	23.5	31.1	28.1	24.1	31.3	28.5	24.4
	S.C.	23.1	21.3	19.6	23.7	22.3	20.2	24.8	23.7	21.6
	KW	4.26	4.10	3.94	4.28	4.12	3.95	4.30	4.15	3.97

NOTE: ALL CAPACITIES ARE NET WITH INDOOR FAN HEAT ALREADY DEDUCTED AT 1250 BTUH/1000 CFM.

Multipliers for determining the performance with other indoor sections.

NOTE: For dry bulb temperatures different than those listed (between 73-87 F), sensible capacity increases by 1060 BTUH per 1000 CFM per degree above the listed temperature and decreases by 1060 BTUH per 1000 CFM per degree below the listed temperature.

Air Handler	Coil	T.C.	S.C.	KW
N1AHB1246	G2FD036(S,H)17	1.02	1.02	1.01
N1AHB1246	G2FD046(S,H)17	1.05	1.06	1.02
	G1FA036S14	1.01	1.02	1.00
	G1FA036S17,21	1.00	1.00	1.00
	G2FD035(S,H)14	0.99	1.00	0.99
	G2FD036(S,H)17	1.02	1.02	1.01
	G2FD036(S,H)21	1.04	1.04	1.00
	G2FD042(S,H)21	1.04	1.05	1.01
	G2FD046(S,H)17	1.05	1.06	1.02
	G2FD048(S,H)21,24	1.07	1.07	1.02
	G1HD036	1.01	1.01	1.00
	G1HD048	1.06	1.06	1.01
	G1NA036S17L	1.06	1.00	1.03
	G1NA048S21D	1.06	1.00	1.03
	G1UA036S14	1.01	1.02	1.00
	G1UA036S17,21	1.00	1.00	1.00
	G1UA048S21	1.06	1.06	1.05

Variable Speed Furnace	Coil	T.C.	S.C.	KW
P1DUA12V	G1FA036S14	0.96	0.97	0.93
P1DUA12V	G2FD035(S,H)14	0.94	0.95	0.93
P1DUB16V	G1FA036S17	0.95	0.96	0.92
P1DUB16V	G2FD036(S,H)17	0.97	0.98	0.92
P1DUC20V	G1FA036S21	0.96	0.97	0.90
P1DUC20V	G2FD036(S,H)21	0.99	1.00	0.91
P1XUB12V	G1FA036S17	0.95	0.95	0.93
P1XUB12V	G2FD036(S,H)17	0.97	0.98	0.94
P1XUC16V	G1FA036S21	0.95	0.96	0.92
P1XUC16V	G2FD036(S,H)21	0.99	1.00	0.92
P1XUC20V	G1FA048S21	1.02	1.02	0.95
P1XUC20V	G2FD042(S,H)21	1.00	1.01	0.92
P1XUD20V	G2FD048(S,H)24	1.02	1.03	0.92

COOLING PERFORMANCE DATA										
AIR CONDITIONER MODEL NO.		H2RC042S06								
INDOOR COIL MODEL NO.		G1FA048S21								
CONDENSING ENTERING AIR TEMPERATURE	IDCFM	1200			1400			1600		
	ID DB (°F)	85	80	75	85	80	75	85	80	75
	ID WB (°F)	72	67	63	72	67	63	72	67	63
75	T.C.	46.4	45.7	43.0	46.4	45.9	43.3	46.5	46.0	43.5
	S.C.	27.0	27.5	27.8	27.9	29.0	29.5	28.8	30.5	31.2
	KW	2.45	2.44	2.45	2.47	2.45	2.46	2.48	2.45	2.46
85	T.C.	45.5	44.1	41.1	45.6	44.4	41.6	45.7	44.7	42.0
	S.C.	27.5	27.5	27.2	28.6	29.2	29.1	29.7	30.9	31.0
	KW	2.76	2.75	2.75	2.77	2.76	2.76	2.78	2.76	2.76
95	T.C.	44.6	42.5	39.2	44.8	43.0	39.8	45.0	43.4	40.4
	S.C.	28.0	27.6	26.5	29.3	29.5	28.6	30.7	31.4	30.7
	KW	3.07	3.06	3.05	3.08	3.07	3.06	3.09	3.07	3.06
105	T.C.	43.7	41.0	37.4	43.9	41.5	38.1	44.2	42.0	38.9
	S.C.	28.4	27.6	25.9	30.0	29.7	28.2	31.6	31.8	30.5
	KW	3.39	3.38	3.36	3.39	3.38	3.36	3.40	3.39	3.37
115	T.C.	41.2	38.1	34.1	41.6	38.7	34.9	42.0	39.3	35.7
	S.C.	27.8	26.7	24.8	29.8	28.9	27.0	31.8	31.0	29.2
	KW	3.80	3.77	3.73	3.81	3.78	3.74	3.81	3.79	3.75
125	T.C.	38.7	35.3	30.9	39.3	35.9	31.8	39.9	36.5	32.6
	S.C.	27.1	25.7	23.7	29.5	28.0	25.8	31.9	30.3	27.9
	KW	4.21	4.16	4.11	4.22	4.18	4.12	4.23	4.19	4.13

NOTE: ALL CAPACITIES ARE NET WITH INDOOR FAN HEAT ALREADY DEDUCTED AT 1250 BTUH/1000 CFM.

Multipliers for determining the performance with other indoor sections.

NOTE: For dry bulb temperatures different than those listed (between 73-87 F), sensible capacity increases by 1060 BTUH per 1000 CFM per degree above the listed temperature and decreases by 1060 BTUH per 1000 CFM per degree below the listed temperature.

Air Handler	Coil	T.C.	S.C.	KW
F2RP/F2FP042		1.02	1.04	1.02
F2FP048		1.04	1.06	1.02
N1AHC1606	G2FD042(S,H)21	0.99	0.99	1.00
N1AHC1606	G2FD048(S,H)21	1.02	1.03	1.02
N1VSC16	G2FD048(S,H)21	1.08	1.11	0.95
	G1FA048S17	1.01	1.02	1.02
	G1FA060S21,24	1.04	1.03	1.01
	G1HD048	1.00	1.00	1.01
	G1NA048S21D	0.99	0.96	1.01
	G1UA048S17	1.01	1.02	1.02
	G1UA048S21	1.00	1.00	1.00
	G1UA060S21,24	1.04	1.03	1.01
	G2FD042(S,H)21	0.99	0.99	1.00
	G2FD046(S,H)17	1.01	1.02	1.02
	G2FD048(S,H)21,24	1.02	1.03	1.02

Variable Speed Furnace	Coil	T.C.	S.C.	KW
P1DUB16V	G1FA048S17	1.02	1.03	0.99
P1DUC20V	G1FA048S21	1.01	1.02	0.97
P1XDD20V	G2FD048(S,H)24	1.04	1.05	0.97
P1XUC16V	G1FA048S21	1.01	1.02	0.97
P1XUD20V	G1FA060S24	1.05	1.05	0.98
P1XUD20V	G2FD048(S,H)24	1.04	1.05	1.00

COOLING PERFORMANCE DATA										
AIR CONDITIONER MODEL NO.		H2RC048S06								
INDOOR COIL MODEL NO.		G1FA048S21								
CONDENSING ENTERING AIR TEMPERATURE	IDCFM	1375			1575			1775		
	ID DB (°F)	85	80	75	85	80	75	85	80	75
	ID WB (°F)	72	67	63	72	67	63	72	67	63
75	T.C.	52.8	49.9	45.4	53.5	50.6	46.8	54.2	51.3	48.2
	S.C.	33.3	32.7	31.5	34.9	34.5	33.6	36.5	36.2	35.7
	KW	3.14	3.09	3.03	3.15	3.10	3.04	3.17	3.12	3.06
85	T.C.	50.9	47.1	42.4	51.6	48.1	43.5	52.3	49.1	44.7
	S.C.	33.3	32.0	30.4	35.3	34.2	32.6	37.4	36.3	34.7
	KW	3.44	3.35	3.30	3.46	3.38	3.31	3.47	3.40	3.32
95	T.C.	49.0	44.3	39.4	49.7	45.5	40.3	50.3	46.8	41.2
	S.C.	33.2	31.2	29.3	35.8	34.1	31.5	38.4	36.5	33.7
	KW	3.74	3.62	3.57	3.76	3.56	3.57	3.78	3.69	3.58
105	T.C.	44.7	40.0	35.8	45.4	41.0	36.5	46.1	42.0	37.1
	S.C.	31.9	29.8	27.8	34.5	32.2	29.9	37.0	34.7	32.1
	KW	4.01	3.89	3.80	4.04	3.91	3.81	4.07	3.94	3.83
115	T.C.	40.5	35.7	32.1	41.2	36.5	32.6	41.9	37.2	33.1
	S.C.	30.5	28.3	26.3	33.1	30.5	28.4	35.7	32.8	30.5
	KW	4.28	4.15	4.02	4.32	4.17	4.05	4.35	4.19	4.08
125	T.C.	36.3	31.3	28.5	36.9	31.9	28.8	37.6	32.5	29.1
	S.C.	29.2	26.8	24.8	31.8	28.9	26.8	34.4	31.0	28.8
	KW	4.55	4.42	4.25	4.60	4.43	4.29	4.64	4.44	4.33

NOTE: ALL CAPACITIES ARE NET WITH INDOOR FAN HEAT ALREADY DEDUCTED AT 1250 BTUH/1000 CFM.

Multipliers for determining the performance with other indoor sections.

NOTE: For dry bulb temperatures different than those listed (between 73-87 F), sensible capacity increases by 1060 BTUH per 1000 CFM per degree above the listed temperature and decreases by 1060 BTUH per 1000 CFM per degree below the listed temperature.

Air Handler	Coil	T.C.	S.C.	KW
F2FP048		1.00	1.00	1.02
F2FP060		1.03	1.03	1.06
F2FV060		1.06	1.10	0.95
N1AHC1606	G2FD048(S,H)21,24	1.00	1.00	1.01
N1AHD2006	G2FD060(S,H)24	1.03	1.03	1.02
N1AHD2006	G2FD061H24	1.04	1.04	1.02
N1VSC16	G2FD048(S,H)21	1.01	1.02	0.97
N1VSD20	G2FD060(S,H)24	1.04	1.06	0.99
N1VSD20	G2FD061H24	1.05	1.07	0.99
	G1FA048S17	0.98	0.98	0.98
	G1FA060S21,24	1.03	1.03	1.02
	G1HD048	0.99	0.99	1.01
	G1HD060	1.02	1.02	1.02
	G1NA048S21D	0.99	0.99	1.02
	G1UA048S17	0.98	0.98	0.98
	G1UA048S21	1.00	1.00	1.00
	G1UA060S21,24	1.03	1.03	1.02
	G2FD046(S,H)17	0.98	0.98	1.00
	G2FD048(S,H)21,24	1.00	1.00	1.01
	G2FD060(S,H)24	1.03	1.03	1.02
	G2FD061H24	1.04	1.04	1.02

Variable Speed Furnace	Coil	T.C.	S.C.	KW
P1DUC20V	G1FA048S21	1.00	1.00	0.99
P1DUC20V	G2FD048(S,H)21	1.00	1.00	1.00
P1XDD20V	G2FD048(S,H)24	1.01	1.01	1.01
P1XUC16V	G1FA048S21	0.99	0.99	1.00
P1XUC16V	G2FD048(S,H)21	0.99	0.98	1.01
P1XUC20V	G1FA048S21	1.00	1.00	0.99
P1XUC20V	G2FD048(S,H)21	1.00	1.00	1.00
P1XUD20V	G1FA060S24	1.04	1.05	1.00
P1XUD20V	G2FD048(S,H)24	1.01	1.01	0.99
P1XUD20V	G2FD060(S,H)24	1.04	1.05	1.00

COOLING PERFORMANCE DATA													
AIR CONDITIONER MODEL NO.		H1RC048S(25,46)											
INDOOR COIL MODEL NO.		G1FA048S21											
CONDENSING ENTERING AIR TEMPERATURE	IDCFM	1400				1600				1750			
	ID DB (°F)	85	80	75	70	85	80	75	70	85	80	75	70
	ID WB (°F)	72	67	63	57	72	67	63	57	72	67	63	57
75	T.C.	53.4	48.9	45.1	40.2	54.3	49.8	45.9	41.3	54.9	50.3	46.4	41.8
	S.C.	32.2	32.3	31.0	32.5	34.0	34.0	32.7	34.7	35.2	35.3	33.9	35.9
	KW	3.81	3.64	3.49	3.32	3.86	3.68	3.53	3.37	3.88	3.71	3.56	3.39
85	T.C.	52.0	47.5	43.7	39.2	52.7	48.3	44.5	40.0	53.2	48.7	45.2	40.5
	S.C.	32.2	32.3	31.1	32.7	34.1	34.1	32.8	34.7	35.4	35.5	34.5	36.0
	KW	4.11	3.92	3.75	3.56	4.16	3.97	3.80	3.60	4.19	4.00	3.83	3.63
95	T.C.	49.0	44.9	41.3	36.9	49.6	45.5	42.0	37.6	50.0	45.8	42.4	38.3
	S.C.	31.6	31.6	30.4	31.8	33.5	33.7	32.4	33.8	34.9	35.0	33.7	35.6
	KW	4.40	4.19	4.00	3.80	4.44	4.23	4.06	3.85	4.48	4.27	4.09	3.88
105	T.C.	45.6	41.6	38.4	34.3	46.0	42.2	39.0	35.0	46.2	42.5	39.3	36.2
	S.C.	30.5	30.6	29.5	30.9	32.6	32.8	31.5	32.8	34.1	34.2	32.7	34.5
	KW	4.67	4.45	4.25	4.03	4.72	4.49	4.30	4.09	4.74	4.53	4.34	4.18
115	T.C.	41.8	38.3	35.3	31.7	42.3	38.8	35.8	33.0	42.5	39.0	36.2	33.5
	S.C.	29.3	29.5	28.2	29.6	31.6	31.4	30.1	31.5	33.0	32.9	31.5	32.0
	KW	4.91	4.67	4.47	4.25	4.94	4.73	4.52	4.36	4.98	4.76	4.56	4.41
125	T.C.	38.0	35.0	32.3	29.1	38.6	35.4	32.7	31.0	38.8	35.5	33.2	30.8
	S.C.	28.1	28.4	26.9	28.3	30.6	30.0	28.7	30.2	31.9	31.6	30.4	29.5
	KW	5.15	4.89	4.69	4.47	5.16	4.97	4.74	4.63	5.22	4.99	4.78	4.64

NOTE: ALL CAPACITIES ARE NET WITH INDOOR FAN HEAT ALREADY DEDUCTED AT 1250 BTUH/1000 CFM.

Multipliers for determining the performance with other indoor sections.

NOTE: For dry bulb temperatures different than those listed (between 73-87 F), sensible capacity increases by 1060 BTUH per 1000 CFM per degree above the listed temperature and decreases by 1060 BTUH per 1000 CFM per degree below the listed temperature.

Air Handler	Coil	T.C.	S.C.	KW
N1AHC1646	G2FD048(S,H)21	1.00	1.00	0.98
N1AHD2046	G2FD060(S,H)24	1.03	1.03	0.99
N1AHD2046	G2FD061H24	1.04	1.04	1.00
	G1FA060S21,24	1.03	1.03	0.99
	G2FD046(S,H)17	0.98	0.98	1.02
	G2FD048(S,H)21,24	1.00	1.00	0.98
	G2FD060(S,H)24	1.03	1.03	0.99
	G2FD061H24	1.04	1.04	1.00
	G1HD048	0.99	0.99	0.98
	G1HD060	1.02	1.07	0.99
	G1NA048S21D	1.01	1.01	0.99
	G1UA048S17	0.98	0.98	1.02
	G1UA048S21	1.00	1.00	1.00
	G1UA060S21,24	1.03	1.03	0.99

Variable Speed Furnace	Coil	T.C.	S.C.	KW
P1DUC20V	G1FA048S21	1.00	1.00	0.98
P1DUC20V	G2FD048(S,H)21	1.00	1.00	0.96
P1XUC16V	G1FA048S21	0.99	0.99	0.99
P1XUC16V	G2FD048(S,H)21	0.99	0.99	0.98
P1XUC20V	G1FA048S21	1.00	1.00	0.99
P1XUC20V	G2FD048(S,H)21	1.00	1.00	0.97
P1XUD20V	G1FA060S24	1.03	1.03	0.98
P1XUD20V	G2FD048(S,H)24	1.00	1.00	0.97
P1XUD20V	G2FD060(S,H)24	1.03	1.03	0.98

COOLING PERFORMANCE DATA										
AIR CONDITIONER MODEL NO.		H3RC060S06, H1RC060S(25,46)								
INDOOR COIL MODEL NO.		G1FA060S21,24								
CONDENSING ENTERING AIR TEMPERATURE	IDCFM	1650			1850			2050		
	ID DB (°F)	85	80	75	85	80	75	85	80	75
	ID WB (°F)	72	67	63	72	67	63	72	67	63
75	T.C.	61.2	58.5	56.3	61.8	59.1	56.9	62.3	59.6	57.5
	S.C.	37.6	37.4	37.1	40.1	39.9	39.5	42.5	42.3	41.8
	KW	4.17	4.09	4.04	4.18	4.10	4.06	4.19	4.10	4.07
85	T.C.	60.6	58.0	55.0	61.2	58.6	55.8	61.9	59.3	56.7
	S.C.	37.6	37.3	36.5	40.2	39.9	39.1	42.8	42.5	41.7
	KW	4.71	4.60	4.55	4.72	4.60	4.56	4.73	4.61	4.58
95	T.C.	60.0	57.4	53.7	60.7	58.2	54.8	61.4	59.0	55.8
	S.C.	37.5	37.1	35.9	40.3	39.9	38.8	43.1	42.6	41.6
	KW	5.24	5.10	5.06	5.25	5.11	5.07	5.26	5.12	5.08
105	T.C.	58.1	54.6	50.0	58.9	55.7	51.3	59.7	56.8	52.7
	S.C.	36.9	36.0	34.4	39.8	39.0	37.3	42.7	41.9	40.2
	KW	5.86	5.72	5.63	5.87	5.74	5.64	5.88	5.77	5.66
115	T.C.	56.2	51.8	46.3	57.1	53.2	47.9	57.9	54.5	49.5
	S.C.	36.2	34.9	32.9	39.3	38.1	35.9	42.3	41.2	38.8
	KW	6.47	6.33	6.19	6.49	6.38	6.22	6.50	6.42	6.24
125	T.C.	54.3	49.0	42.6	55.2	50.6	44.5	56.2	52.3	46.4
	S.C.	35.6	33.8	31.4	38.7	37.2	34.4	41.9	40.5	37.4
	KW	7.09	6.95	6.76	7.10	7.01	6.79	7.12	7.07	6.82

NOTE: ALL CAPACITIES ARE NET WITH INDOOR FAN HEAT ALREADY DEDUCTED AT 1250 BTUH/1000 CFM.

Multipliers for determining the performance with other indoor sections.

NOTE: For dry bulb temperatures different than those listed (between 73-87 F), sensible capacity increases by 1060 BTUH per 1000 CFM per degree above the listed temperature and decreases by 1060 BTUH per 1000 CFM per degree below the listed temperature.

Air Handler	Coil	T.C.	S.C.	KW
F2FP060		0.98	0.98	1.00
F2FV060		1.00	1.00	0.98
N1VSD20	G2FD060(S,H)24	1.00	1.00	0.98
N1VSD20	G2FD061H24	1.01	1.00	0.97
N1AHD2046	G2FD060(S,H)24	1.00	1.00	1.00
N1AHD2046	G2FD061H24	1.01	1.01	1.00
	G2FD060(S,H)24	1.00	1.00	1.00
	G2FD061H24	1.01	1.01	1.00
	G1HD060	1.00	1.00	1.01
	G1NA060S24T	1.00	0.91	0.99
	G1UA060S21,24	1.00	1.00	1.00

Variable Speed Furnace	Coil	T.C.	S.C.	KW
P1XUC20V	G1FA060S21	0.99	0.99	1.01
P1XUD20V	G1FA060S24	0.99	0.99	0.99
P1XUD20V	G2FD060(S,H)24	0.99	0.99	0.99
P1XUD20V	G2FD061H24	1.01	1.01	0.99
P1XDD20V	G2FD060(S,H)24	0.99	1.00	1.04

MATCHING INDOOR COMPONENTS

ADD-ON COILS - FOR FURNACE APPLICATIONS

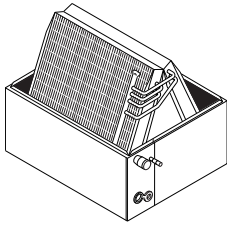

G1UA
1/2 CASED
UPFLOW

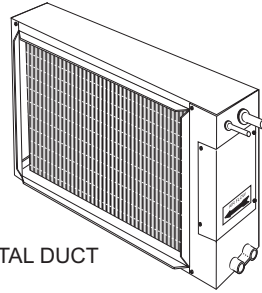

G1HD
HORIZONTAL DUCT

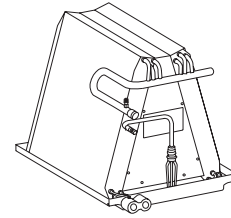

G1NA
UNCASED
UPFLOW

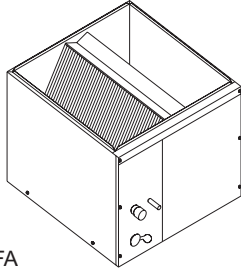

G1FA
FULL CASED
UPFLOW

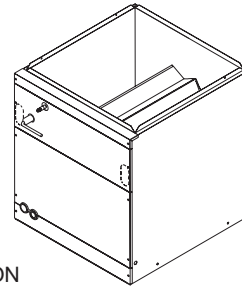

G2FD*
MULTI-POSITION
(UPFLOW, HORIZONTAL
AND DOWNFLOW)

* Available with factory installed horizontal drain pan.

AIR HANDLERS - FOR NON-FURNACE APPLICATIONS

N1AH OR N1VS
MODULAR BLOWER
(UPFLOW, HORIZONTAL
AND DOWNFLOW)

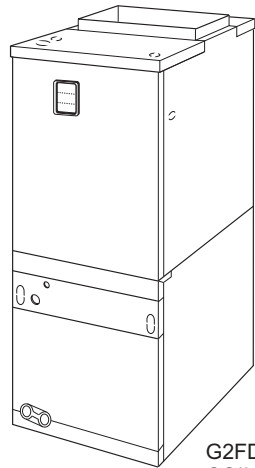

G2FD
COIL

F2RC / F2FC OR
F2RP / F2FP / F3RP / F3FP/ F2FV
FAN COIL UNITS (UPFLOW, HORIZONTAL)

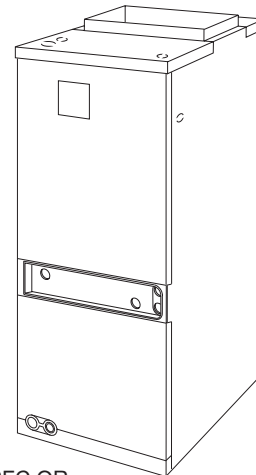

NOTES

