



Heating and Air Conditioning

TECHNICAL GUIDE

SPLIT-SYSTEM HEAT PUMPS

12 SEER

MODELS:

E*RC018 THRU 060
(1.5 THRU 5 TONS, 1 PH)

E*RC036 THRU 060
(3 THRU 5 TONS, 3 PH)



This product was manufactured in a plant whose quality system is certified/registered as being in conformity with ISO 9001.



Certification applies only when the complete system is listed with ARI.



Due to continuous product improvement, specifications are subject to change without notice.

Visit us on the web at www.york.com for the most up-to-date technical information.

Additional rating information can be found at www.ariprimenet.org.

DESCRIPTION

The 12 SEER series heat pumps are designed for use with a variety of UPG evaporator sections to suit any application need. A full line of matching Add-On Coils are available for use with upflow, downflow or horizontal furnaces. Matching Air Handlers are also available for upflow, downflow or horizontal installation to provide a complete system. Electric heat may be installed in air handlers. All units are factory charged to assure easy installation.

WARRANTY

Single Phase Units:

5-year limited parts warranty.

10-year limited compressor warranty.

Three Phase Units:

1-year limited parts warranty.

5-year limited compressor warranty.

FEATURES

- **DURABLE CONSTRUCTION** - The outdoor unit is constructed of pre-painted steel that offers tough protection against corrosion and resists fading when exposed to sunlight. Drain holes are incorporated into the base pan to permit free drainage of moisture.
- **QUALITY COILS** - The coil is constructed of copper tube and aluminum fins.
- **COIL PROTECTION** - Coils are protected from damage by a polymer mesh applied between the coil face, and a PVC coated steel coil guard.
- **PROTECTED COMPRESSOR** - The hermetic compressor is internally protected against high pressure and temperature by the simultaneous operation of a high pressure relief valve and temperature sensors which stop the compressor if operating temperatures go too high. Both protectors reset automatically. A discharge line solid core filter drier further protects the compressor.
- **TIME TEMPERATURE DEFROST CONTROL** - Includes a five-minute anti-short cycle timer to protect the compressor from short cycling. Field selectable 30, 60, 90 minutes defrost intervals.
- **LOW OPERATING SOUND LEVEL** - The compressor is mounted on rubber isolators to reduce operating sounds. The slow moving condenser fan keeps air turbulence and sound to a low level.
- **EASY ACCESS** - Removable panel affords accessibility to the electrical box.
- **FULLY CHARGED AND FACTORY WIRED** - to simplify installation and reduce labor costs. Only power supply and control wiring and refrigerant lines must be connected. All models are sweat connect with reusable service valves.
- **Factory tested** - to verify system operation and control functioning before shipment.
- **U.L. and C.U.L. listed** - approved for outdoor application.

Certified in accordance with the Unitary Small Equipment certification program, which is based on ARI Standard 210/240.

Physical and Electrical Data - 1 Phase

MODEL		E1RC018S06	E1RC024S06	E1RC030S06	E1RC036S06	E1RC042S06	E2RC048S06	E2RC060S06
Unit Supply Voltage		208/230 – 1 – 60						
Normal Voltage Range ¹		187 to 252						
Minimum Circuit Ampacity		11.7	14.9	18.4	21.3	30.6	31.1	42.6
Max. Overcurrent Device Amps ²		20	25	30	30	45	50	70
Compressor Type ³		Inertia	Inertia	Inertia	Inertia	Scroll	Scroll	Scroll
Compressor Amps	Rated Load	9.0	10.9	13.7	16	23.5	23.8	33.1
	Locked Rotor	48	60	75	81	104	124	175
Crankcase Heater		Yes	Yes	Yes	Yes	No	No	No
Fan Motor Amps	Rated Load	0.5	1.3	1.3	1.3	1.3	1.3	1.3
	Fan Diameter Inches	18	22	22	22	22	24	24
Fan Motor	Rated HP	1/12	1/4	1/4	1/4	1/4	1/4	1/4
	Nominal RPM	1,100	850	850	850	850	850	850
	Nominal CFM	1,850	3,150	3,150	3,150	3,150	3,250	3,250
Coil	Face Area Sq. Ft.	12.58	15.72	15.72	19.65	19.65	22.50	22.50
	Rows Deep	1	1	1	1	1	2	2
	Fin / Inches	13	13	13	13	13	14	14
Liquid Line OD		3/8	3/8	3/8	3/8	3/8	3/8	3/8
Vapor Line OD		3/4	3/4	3/4	7/8	7/8	7/8	1 1/8
Unit Charge (Lbs. - Oz.) ⁴		5 - 13	6 - 7	6 - 9	7 - 4	7 - 1	13 - 9	12 - 11
Charge Per Foot, Oz.		0.68	0.68	0.68	0.70	0.70	0.70	0.76
Operating Weight Lbs.		142	163	167	178	180	254	262

Physical and Electrical Data - 3 Phase

MODEL		E1RC036S25	E1RC048S25	E1RC060S25	E1RC036S46	E1RC048S46	E1RC060S46
Unit Supply Voltage		208/230-3-60			460 - 3 - 60		
Normal Voltage Range ¹		187-252			432-504		
Minimum Circuit Ampacity		13.7	20.8	24.2	7.2	10.5	11.7
Max. Overcurrent Device Amps ²		20	35	40	15	15	20
Compressor Type ³		Recip	Scroll ^B	Scroll ^C	Recip	Scroll ^B	Scroll ^C
Compressor Amps	Rated Load	9.9	15.6	18.3	5.1	7.7	8.7
	Locked Rotor	78	93	123	40	47	62
Crankcase Heater		Yes	No	No	Yes	No	No
Fan Motor Amps	Rated Load	1.3	1.3	1.3	0.8	0.8	0.8
	Fan Diameter Inches	22	24	24	22	24	24
Fan Motor	Rated HP	1/4	1/4	1/4	1/4	1/4	1/4
	Nominal RPM	850	850	850	850	850	850
	Nominal CFM	3,300	3,400	3,400	3,300	3,400	3,400
Coil	Face Area Sq. Ft.	19.65	27.00	27.00	19.65	27.00	27.00
	Rows Deep	1	2	2	1	2	2
	Fin / Inches	18	14	14	18	14	14
Liquid Line OD		3/8	3/8	3/8	3/8	3/8	3/8
Vapor Line OD		3/4	7/8	7/8	3/4	7/8	7/8
Unit Charge (Lbs. - Oz.) ⁴		9 - 5	13 - 9	12 - 9	9 - 5	13 - 9	12 - 9
Charge Per Foot, Oz.		0.68	0.70	0.70	0.68	0.70	0.70
Operating Weight Lbs.		185	240	258	185	241	258

1. Rated in accordance with ARI Standard 110, utilization range "A".
2. Dual element fuses or HACR circuit breaker.
3. All scrolls listed with a superscript "B" are Bristol scrolls. All scrolls listed with a superscript "C" are Copeland scrolls.
4. The Unit Charge is correct for the outdoor unit, matched indoor coil and 15 feet of refrigerant tubing. For tubing lengths other than 15 feet, add or subtract the amount of refrigerant, using the difference in length multiplied by the per foot value.

Additional R-22 Charge / Orifice Size for Various Matched Systems - 1 Phase

Outdoor Unit	E1RC018S06	E1RC024S06	E1RC030S06	E1RC036S06	E1RC042S06	E2RC048S06	E2RC060S06
Unit Orifice (s) ¹	53,55	59,61	67,69,71	71,75	81	87	96
Factory R-22 Charge, lbs-oz	5 - 13	6 - 7	6 - 9	7 - 4	7 - 1	13 - 9	12 - 11
Indoor Coil	Coil Orifice ²	System Orifice - Additional Charge, Oz					
G2FD024(S,H)14,17(T)	61	53 + 2 ⁴	701 ^{3,5} + 0				
G2FD030(S,H)17(T)	65		61 + 0 ⁴	69 + 3			
			701 ^{3,5} + 0	701 ^{3,5} + 3			
G2FD035(S,H)14	65		61 + 0 ⁴	69 + 3			
G2FD036(S,H)17,21(T)	75			71 + 5 ⁴	75 + 0 ⁴		
				701 ³ + 5	702 ^{3,5} + 0		
G2FD042(S,H)21(T)	78				75 + 3	78 + 11 ⁴	
					702 ^{3,5} + 0	702 ^{3,5} + 11	
G2FD046(S,H)17	78				75 + 3		
G2FD048(S,H)21,24	84					702 ³ + 14	87 + 0
						81 + 17	
G2FD060(S,H)24	90					81 + 24	87 + 0
						702 ³ + 24	96 + 5 ⁴
G2FD061H24	90						87 + 10
							96 + 15 ⁴
G1HA024H14	61	53 + 02					
G1HA024H14T	TXV 701	+02	+0				
G1HA036H14	75						
G1HA036H14T	TXV 702			+05	+0		
G1HA036H17	78				75 + 03	78 + 11	
G1HA036H17T	TXV 702				+0	+11	
G1HA048H21	84				75 + 08		87 + 00
G1HA048H21T	TXV 703						
G1HA060H24	90						87 + 05
G1HA060H24T	TXV 703						96 + 05
G1HD024	59	53 + 0 ⁴	701 ³ + 0				
G1HD036	69		61 + 6 ⁴	701 ³ + 8	702 ³ + 2		
G1HD048	81			69 + 14 ⁴	75 + 7 ⁴	78 + 7 ⁴	
G1HD060	93						87 + 0
							96 + 1 ⁴
G1FA/G1UA024S14,17	59	53 + 0 ⁴					
G1FA/G1UA030S14	65	53 + 0	701 ³ + 0				
G1FA/G1UA036S14	73			69 + 5 ⁴			
G1FA/G1UA036S17,21	73		61 + 0 ⁴	69 + 3 ⁴			
G1FA/G1UA048S21	84				75 + 8 ⁴	81 + 11 ⁴	87 + 0
G1FA/G1UA060S21,24	90						87 + 5
							96 + 5 ⁴
G1NA030S17K	63	55 + 4 ⁴	59 + 1 ⁴				
G1NA030S21M	63		59 + 1 ⁴				
G1NA036S17L	71			67 + 0 ⁴	71 + 11 ⁴		
G1NA048S21D	78			67 + 0 ⁴	71 + 11 ⁴	78 + 0 ⁴	
G1NA048S24P	78					78 + 0 ⁴	
G1NA042S24W	84						87 + 20
G1NA060S24T	87						96 + 0 ⁴
G1NF036SOF	67		59 + 1 ⁴	67 + 1 ⁴	71 + 11 ⁴		
G1NF048SOF	78					78 + 0 ⁴	
G1NF060SOF	87						87 + 20 ⁴
							96 + 9 ⁴
F2RP/F2FP024	61	55 + 0					
F2RP/F2FP030	65		61 + 0				
F2RP/F2FP036	75			71 + 7	75 + 0		

Additional R-22 Charge / Orifice Size for Various Matched Systems - 1 Phase

Outdoor Unit	E1RC018S06	E1RC024S06	E1RC030S06	E1RC036S06	E1RC042S06	E2RC048S06	E2RC060S06
Unit Orifice (s) ¹	53,55	59,61	67,69,71	71,75	81	87	96
Factory R-22 Charge, lbs-oz	5 - 13	6 - 7	6 - 9	7 - 4	7 - 1	13 - 9	12 - 11
Indoor Coil	Coil Orifice ²	System Orifice - Additional Charge, Oz					
F2RP/F2FP042 (T)	78			75 + 3	702 ^{3,5} + 11		
F2FP045	78					87 + 5	
F2FP048 (T)	84				81 + 17	703 ^{3,5} + 0	
F2FP060 (T)	90						703 ^{3,5} + 5
F2FV060	90					87 + 5	96 + 5

FOOTNOTES:

1. These orifices are packed in the customer packet of each outdoor unit.
2. These orifices are factory mounted in the flow control device of each indoor coil. A TXV is factory mounted if model number has (T) suffix.
3. A TXV kit must be used with these coils to obtain system performance. (701,702,703 indicates 1TV07 ...series).
4. Systems matched with furnaces or air handlers not equipped with blower-off delays, may require blower Time Delay Kit #2FD0670224.
5. This TXV is factory installed on Indoor Coil model with (T) suffix.

PROCEDURES:

1. Unit factory charge listed on the unit nameplate includes refrigerant for the condenser, the smallest evaporator and for 15 feet of interconnecting line tubing.
2. Verify the orifice size and additional charge required for specific evaporator coil in the system using the above table.
3. Additional charge for the amount of interconnecting line tubing greater than 15 feet at the rate specified in the table above.
4. Permanently mark the unit nameplate with the total system charge. Total System Charge = Base Charge (as shipped) + adder for evaporator + adder for line set.
5. If the orifice in the evaporator was changed, verify the evaporator nameplate has been marked with the correct orifice size.

Additional R-22 Charge / Orifice Size for Various Matched Systems - 3 Phase

Outdoor Unit	E1RC036S(25,46)	E1RC048S(25,46)	E1RC060S(25,46)
Unit Orifice (s) ¹	73	87	99
Factory R-22 Charge, lbs-oz	9 - 5	13 - 9	12 - 9
Indoor Coil	Coil Orifice ²	System Orifice = Additional Charge, Oz	
G1UA048S(21,24)	84	73 + 0	87 + 0
G1UA060S24	90	—	87 + 5
G1FA048S(21,24)	84	73 + 0	87 + 0
G1FA060S24	90	—	87 + 5
G1HA048H21	84	73 + 2	—
G1HA060H24	90	—	87 + 5
G2FD048S(21,24)	84	73 + 2	87 + 2
G2FD060S24	90	—	87 + 5

Footnotes:

1. These orifices are packed in the instruction/warranty packet of each outdoor unit.
2. These orifices are factory mounted in the flow control device of each indoor coil.
3. A TXV is factory mounted in the coil or air handler.

PROCEDURES:

1. Unit factory charge listed on the unit nameplate includes refrigerant for the condenser, the smallest evaporator and for 15 feet of interconnecting line tubing.
2. Verify the orifice size and additional charge required for specific evaporator coil in the system using the above table.
3. Additional charge for the amount of interconnecting line tubing greater than 15 feet at the rate specified in the table above.
4. Permanently mark the unit nameplate with the total system charge. Total System Charge = Base Charge (as shipped) + adder for evaporator + adder for line set.
5. If the orifice in the evaporator was changed, verify the evaporator nameplate has been marked with the correct orifice size.

COOLING CAPACITY - With Air Handler Coils

UNIT MODEL	AIR HANDLER			COIL ^{1,6} MODEL	COOLING					
	MODEL ⁶	ELECTRIC ² HEAT KW	W		RATED CFM	NET MBH		SEER W/O TXV	SEER + TXV ³	EER
1 PH 12 SEER HP WITH N-AH / G2FD										
E1RC018S06	N1AHB0806	2,5,8,10	17	G2FD024(S,H)17 (T)	650	17.8	12.8	-	12.00	10.35
E1RC024S06	N1AHB0806	2,5,8,10	17	G2FD024(S,H)17 (T)	840	23.4	17.3	-	12.00	10.25
	N1AHB0806	2,5,8,10	17	G2FD030(S,H)17 (T)	840	23.8	17.6	12.0	12.10	10.35
E1RC030S06	N1AHB1206	5,8,10,15,19	17	G2FD036(S,H)17 (T)	1025	28	20.7	11.8	12.00	10.30
E1RC036S06	N1AHB1206	5,8,10,15,19	17	G2FD036(S,H)17 (T)	1250	33.4	24.7	12.0	12.10	10.10
E1RC042S06	N1AHC1606	5,8,10,15,20	21	G2FD042(S,H)21 (T)	1400	40	30.0	12.0	12.00	10.45
E2RC048S06	N1AHC1606	5,8,10,15,20	21	G2FD048(S,H)21	1600	45.5	33.3	12.0	-	10.70
	N1AHD2006	8,10,15,20,25,30	24	G2FD060(S,H)24	1600	46.5	34.4	12.0	-	10.90
	N1AHD2006	8,10,15,20,25,30	24	G2FD061H24	1600	47	36.3	12.0	-	11.00
E2RC060S06	N1AHD2006	8,10,15,20,25,30	24	G2FD060(S,H)24	1700	57.5	40.4	12.0	-	10.75
	N1AHD2006	8,10,15,20,25,30	24	G2FD061H24	2000	59	44.0	-	12.00	10.80
1 PH 12 SEER HP / N1VS - VARIABLE SPEED										
E1RC018S06	N1VSB12	5,8,10,15,19	17	G2FD024(S,H)17	645	18.4	12.8	13.00	-	11.80
E1RC024S06	N1VSB12	5,8,10,15,19	17	G2FD030(S,H)17	785	24.4	17.6	13.00	-	11.50
E1RC030S06	N1VSB12	5,8,10,15,19	17	G2FD036(S,H)17	1000	28.6	20.7	13.00	-	11.20
E1RC036S06	N1VSB12	5,8,10,15,19	17	G2FD036(S,H)17	1150	34.0	24.7	13.00	-	11.00
	N1VSB12	5,8,10,15,19	17	G2FD046(S,H)17	1150	34.6	25.1	13.00	-	11.00
E1RC042S06	N1VSC16	5,8,10,15,20	21	G2FD048(S,H)21	1425	41.5	30.4	13.00	-	11.00
E2RC048S06	N1VSD20	8,10,15,20,25,30	24	G2FD060(S,H)24 (T)	1600	47.0	34.4	-	12.60	11.40
	N1VSD20	8,10,15,20,25,30	24	G2FD061H24	1600	47.5	36.3	-	12.65	11.55
E2RC060S06	N1VSD20	8,10,15,20,25,30	24	G2FD060(S,H)24 (T)	1860	59.0	40.4	-	13.50	11.90
	N1VSD20	8,10,15,20,25,30	24	G2FD061H24	1900	59.5	44.0	-	12.35	11.05
1 PH 12 SEER HP / F2RP / FP / FV ^{4,5}										
E1RC018S06	F2RP/F2FP024	5,8,10	18	-	650	18.0	13.3	12.00	-	10.50
E1RC024S06	F2RP/F2FP030	5,8,10,15	18	-	800	23.6	17.5	12.00	-	10.50
E1RC030S06	F2RP/F2FP030	5,8,10,15	18	-	1025	27.8	20.6	11.30	-	10.25
	F2RP/F2FP036	5,8,10,15,19	21	-	1000	28.6	21.2	12.00	-	10.60
E1RC036S06	F2RP/F2FP036	5,8,10,15,19	21	-	1200	34.0	25.2	12.00	-	10.40
	F2RP/F2FP042	5,8,10,15	21	-	1200	34.0	25.2	12.00	-	10.40
E1RC042S06	F2RP/F2FP042 (T)	5,8,10,15	21	-	1400	39.5	29.2	-	11.70	10.25
	F2FP048	5,8,10,15,20,25	24	-	1400	41.0	30.3	12.00	-	10.60
E2RC048S06	F2FP045	5,8,10,15	24	-	1500	46.0	33.5	12.00	-	11.00
	F2FP048 (T)	5,8,10,15,20,25	24	-	1600	45.5	33.7	-	12.00	10.55
	F2FV060	8,10,15,20,25	24	-	1600	47.0	35.9	12.60	-	11.40
E2RC060S06	F2FP060 (T)	5,8,10,15,20,25	24	-	1700	57.0	39.9	-	12.00	10.40
	F2FV060	8,10,15,20,25	24	-	1900	57.5	43.4	12.30	-	10.65

Rated in accordance with DOE test procedures (Federal Register 12-27-79 and 3-18-88) and ARI Standards 210.

Cooling MBH based on 80°F entering air temperature, 50% RH, and rated air flow.

EER (Energy Efficiency Ratio) is the total cooling output in BTU's at a 95°F outdoor ambient divided by the total electric power in watt-hours at those conditions.

SEER (Seasonal Energy Efficiency Ratio) is the total cooling output in BTU's during a normal annual usage period for cooling divided by the total electric power input in watt-hours during the same period.

1. G2FD coils available with a factory installed horizontal drain pan. See price pages for specific model number.
 2. Single phase units require single phase 2HK heaters. Three phase units require three phase 2HK heaters.
 3. TXV = Thermal Expansion Valve kit required. Use 1TV700 series kit.
 4. To meet R=4.2 insulation requirements, substitute F2FP for F2RP, and F2FC for F2RC. models. All ratings remain the same.
 5. FG8, FG9, and FL8 furnaces and F2RP / F2RC air handlers have B.O.D (Blower on Delay) standard.
 6. A TXV is factory mounted in the Indoor Coil or Air Handler with model numbers containing a (T) suffix.
- = Not applicable

COOLING CAPACITY - Upflow, Downflow, & Horizontal Furnaces and Coils

UNIT MODEL	FURNACE**		COIL ¹ MODEL	COOLING					
	CFM RANGE (MIN.-MAX.)	W		RATED CFM	NET MBH		SEER W/O TXV	SEER + TXV ²	EER
					TOTAL	SENS.			
E1RC018S06	575 725	14,17	G1FA024S14,17	650	17.6	13.0	11.70*	-	10.30
		14	G1FA030S14	650	17.8	13.2	11.85*	-	10.40
		14	G1HA024H14 (T)	650	17.4	12.8	12.00	12.00	10.25
		-	G1HD024	650	18.0	12.2	12.00*	-	10.55
		17	G1NA030S17K	650	18.0	12.2	12.00*	-	10.50
		14,17	G1UA024S14,17	650	17.6	13.0	11.70*	-	10.30
		14	G1UA030S14	650	17.8	13.2	11.85*	-	10.40
		14,17	G2FD024(S,H)14,17(T)	650	17.8	12.8	-	12.00	10.35
E1RC024S06	750 950	14	G1FA030S14(T)	840	23.4	17.3	-	12.00	10.25
		17,21	G1FA036S17,21	840	23.8	17.6	12.00*	-	10.35
		14	G1HA024H14T	840	23.0	17.3	12.00	12.00	10.25
		-	G1HD024	840	23.8	18.7	-	12.20	10.35
		-	G1HD036	840	24.2	19.0	12.00*	-	10.50
		17	G1NA030S17K	850	23.6	16.9	12.00	-	10.50
		21	G1NA030S21M	850	23.6	16.9	12.00	-	10.50
		14	G1UA030S14	840	23.4	17.3	-	12.00	10.25
		17,21	G1UA036S17,21	840	23.8	17.6	12.00*	-	10.35
		14,17	G2FD024(S,H)14,17(T)	840	23.4	17.3	-	12.00	10.25
E1RC030S06	900 1150	17	G2FD030(S,H)17(T)	840	23.8	17.6	12.00*	12.10	10.35
		14	G2FD035(S,H)14	840	23.8	17.6	12.00*	-	10.35
		14	G1FA036S14	1025	28.2	20.4	11.50*	-	10.35
		17,21	G1FA036S17,21	1025	27.8	20.6	11.50*	-	10.25
		14	G1HA036H14T	1025	27.4	20.7	12.00	12.00	10.45
		-	G1HD036	1025	28.2	22.4	-	12.00	10.35
		-	G1HD048	1025	29.4	23.3	12.15*	-	10.70
		17	G1NA036S17L	1000	30.0	20.7	12.00*	-	10.90
		21	G1NA048S21D	1000	30.0	20.7	12.00*	-	10.85
		14	G1UA036S14	1025	28.2	20.4	11.50*	-	10.35
		17,21	G1UA036S17,21	1025	27.8	20.5	11.50*	-	10.25
		17	G2FD030(S,H)17(T)	1025	27.8	20.5	11.50*	11.65	10.25
E1RC036S06	1050 1350	14	G2FD035(S,H)14	1025	27.8	20.5	11.65	-	10.25
		17	G2FD036(S,H)17	1025	28.0	20.7	11.80*	12.00	10.30
		21	G2FD036(S,H)21	1025	28.0	20.7	-	12.00	10.55
		21	G1FA048S21	1250	34.8	25.8	12.20*	-	10.50
		14	G1HA036H14T	1150	33.6	25.2	-	12.00	10.35
		17	G1HA036H17(T)	1200	33.4	25.4	12.00	12.00	10.30
		21	G1HA048H21	1200	34.0	25.8	12.00	12.00	10.50
		-	G1HD036	1250	33.4	26.4	-	12.00	10.10
		-	G1HD048	1250	36.0	27.9	12.00*	-	10.50
		17	G1NA036S17L	1200	34.0	24.1	12.00*	-	10.70
		21	G1NA048S21D	1200	34.0	24.1	12.00*	-	10.60
		21,24	G1UA048S21	1250	34.8	25.8	12.20*	-	10.50
E1RC036S(25,46)	1050 1450	17	G2FD036(S,H)17(T)	1250	33.4	24.7	12.00*	12.10	10.10
		21	G2FD036(S,H)21(T)	1200	34.0	25.2	-	12.15	10.35
		21	G2FD042(S,H)21(T)	1250	34.2	25.4	12.10*	12.20	10.30
		21	G1FA048(S,H)21	1250	34.6	25.8	12.00	-	10.55
		21	G1HA048H21	1250	34.4	25.1	12.00	-	10.50
		21	G1UA048(S,H)21	1250	34.6	25.8	12.00	-	10.55
		21,24	G2FD048(S,H)21,24	1250	35.0	25.1	12.00	-	10.70

For Notes see Page 7.

COOLING CAPACITY - Upflow, Downflow, & Horizontal Furnaces and Coils (Continued)

UNIT MODEL	FURNACE**		COIL ¹ MODEL	COOLING					
	CFM RANGE (MIN.-MAX.)	W		RATED CFM	NET MBH		SEER W/O TXV	SEER + TXV ²	EER
					TOTAL	SENS.			
E1RC042S06	1225 1575	21	G1FA048S21	1400	40.5	30.0	12.00*	-	10.65
		17	G1HA036H17(T)	1300	39.5	30.0	12.00	12.00	10.35
		-	G1HD048	1400	40.5	31.5	12.00*	-	10.60
		21	G1NA048S21D	1400	40.5	29.7	12.00*	-	10.50
		21,24	G1UA048S21	1400	40.5	30.0	12.00*	-	10.65
		21	G2FD042(S,H)21(T)	1400	40.0	30.0	12.00*	12.00	10.45
		21,24	G2FD048(S,H)21,24(T)	1450	40.5	30.4	-	12.00	10.65
		24	G2FD060(S,H)24(T)	1400	41.0	30.8	12.10*	12.30	10.90
E2RC048S06	1400 1800	21	G1FA048S21	1500	45.5	33.0	12.00	-	10.80
		21,24	G1FA060S21,24	1600	46.5	34.4	12.00	-	10.90
		21	G1HA048H21	1500	44.5	33.0	12.00	-	10.80
		24	G1HA060H24	1600	46.0	34.4	12.00	-	10.90
		-	G1HD060	1600	46.0	34.1	12.00	-	10.80
		24	G1NA042S24W	1500	46.0	32.8	12.00	-	10.75
		21,24	G1UA048S21	1500	45.5	33.0	12.00	-	10.80
		21,24	G1UA060S21,24	1600	46.5	34.4	12.00	-	10.90
		21,24	G2FD048(S,H)21,24	1600	45.5	33.3	12.00	-	10.70
		24	G2FD060(S,H)24	1600	46.5	34.4	12.00	-	10.90
		24	G2FD061H24	1600	47.0	36.3	12.00	-	11.00
E1RC048S(25,46)	1400 1800	21	G1FA048(S,H)21	1600	45.0	32.5	12.00	-	10.25
		21,24	G1FA060(S,H)21,24	1600	45.5	33.0	12.00	-	10.35
		24	G1HA060H24	1600	45.0	32.5	12.00	-	10.30
		21	G1UA048(S,H)21	1600	45.0	32.6	12.00	-	10.25
		21,24	G1UA060(S,H)21,24	1600	45.5	33.0	12.00	-	10.35
		21,24	G2FD048(S,H)21,24	1600	45.0	32.5	12.00	-	10.25
		24	G2FD060(S,H)24	1600	45.5	33.0	12.00	-	10.35
E2RC060S06	1600 2100	21,24	G1FA060S21,24	1700	57.5	40.4	12.00*	-	10.75
		24	G1HA060H24	1700	57.5	40.0	12.00	-	10.75
		-	G1HD060	1800	58.0	40.7	12.00*	-	10.80
		24	G1NA060S24T	1800	56.5	39.6	12.00*	-	10.55
		21,24	G1UA060S21,24	1700	57.5	40.4	12.00*	-	10.75
		24	G2FD060(S,H)24	1700	57.5	40.4	12.00*	-	10.75
		24	G2FD061H24	2000	59.0	44.0	-	12.00*	10.80
E1RC060S(25,46)	1500 1900	21,24	G1FA060(S,H)21,24	1700	55.5	38.4	12.00	-	10.70
		24	G1HA060H24	1700	55.0	37.5	12.00	-	10.70
		21,24	G1UA060(S,H)21,24	1700	55.5	38.4	12.00	-	10.70
		24	G2FD060(S,H)24	1700	55.5	38.4	12.00	-	10.70

1. A TXV is factory mounted in the Indoor Coil or Air Handler with model numbers containing a (T) suffix.

2. TXV = Use 1TV700 Series Kit.

* Requires a 2FD Blower Time Delay unless a standard furnace is equipped with one.

** Refer to Quick Selection Chart for specific furnace match-up.

COOLING CAPACITY - With Variable Speed Furnaces

UNIT MODEL	VARIABLE SPEED FURNACE MODEL	COIL MODEL ^{1,4}	W	COOLING					
				RATED CFM	NET MBH		SEER W/O TXV	SEER + TXV ²	EER
					TOTAL	SENS.			
1 PH 12 SEER HP - VARIABLE SPEED³									
E1RC018S06	P1DUA12V	G1FA024S14(T)	14	685	18.0	13.4	-	12.75	11.40
	P1DUA12V	G1FA030S14(T)	14	685	18.2	13.6	-	13.00	11.55
	P1DUA12V	G2FD024(S,H)14(T)	14	685	18.2	13.2	-	13.00	11.50
	P1XDB12V	G2FD024(S,H)17(T)	17	620	18.2	13.2	-	13.00	11.75
	P1XUB12V	G1FA024S17(T)	17	660	18.0	13.4	-	12.75	11.40
	P1XUB12V	G2FD024(S,H)17(T)	17	660	18.2	13.2	-	13.00	11.50
E1RC024S06	P1DUA12V	G1FA030S14(T)	14	875	23.8	17.7	-	12.75	11.05
	P1DUA12V	G2FD024(S,H)14(T)	14	875	23.8	17.7	-	12.75	11.05
	P1DUB16V	G1FA036S17	17	840	24.2	18.0	-	12.75	11.20
	P1DUB16V	G2FD024(S,H)17(T)	17	840	23.8	17.7	-	12.75	11.05
	P1DUB16V	G2FD030(S,H)17(T)	17	840	24.2	18.0	-	13.00	11.15
	P1XDB12V	G2FD024(S,H)17(T)	17	815	23.6	17.5	-	13.00	11.30
	P1XDB12V	G2FD030(S,H)17(T)	17	830	24.2	18.0	-	13.20	11.60
	P1XUB12V	G1FA036S17	17	820	24.4	18.2	-	13.00	11.35
	P1XUB12V	G2FD024S17(T)	17	820	24.0	17.9	-	13.00	11.20
	P1XUB12V	G2FD030S17(T)	17	820	24.4	18.2	-	13.00	11.35
E1RC030S06	P1DUA12V	G1FA036S14	14	1080	28.6	20.8	-	12.00	10.80
	P1DUA12V	G2FD035(S,H)14(T)	14	975	28.2	20.9	-	12.50	11.05
	P1DUB16V	G1FA036S17	17	1050	28.4	21.2	-	12.25	11.20
	P1DUB16V	G2FD036(S,H)17	17	1050	28.6	21.3	-	12.75	11.25
	P1XUB12V	G1FA036S17	17	1050	28.2	21.0	-	12.25	10.95
	P1XUB12V	G2FD030(S,H)17(T)	17	1050	28.2	20.9	-	12.50	10.95
	P1XUB12V	G2FD036(S,H)17	17	1050	28.4	21.1	-	12.75	11.05
	P1XDB12V	G2FD036(S,H)17	17	1040	28.2	20.9	-	12.40	10.85
E1RC036S06	P1DUB16V	G2FD036(S,H)17(T)	17	1250	33.8	25.1	-	12.50	10.70
	P1DUC20V	G1FA048S21	21	1250	35.4	26.4	-	12.75	11.40
	P1DUC20V	G2FD036(S,H)21(T)	21	1200	34.6	25.8	-	12.75	11.15
	P1DUC20V	G2FD042(S,H)21(T)	21	1200	34.8	26.2	-	12.75	11.10
	P1XDB12V	G2FD036(S,H)17(T)	17	1130	33.4	24.7	-	12.00	10.85
	P1XUB12V	G2FD036(S,H)17(T)	17	1200	33.8	25.1	-	12.25	10.50
	P1XUC16V	G1FA048S21	21	1260	35.4	26.4	-	12.75	11.20
	P1XUC16V	G2FD036(S,H)21(T)	21	1200	34.4	25.6	-	12.75	11.00
	P1XUC16V	G2FD042(S,H)21(T)	21	1200	34.8	26.2	-	12.75	11.00
E1RC042S06	P1DUC20V	G1FA048S21	21	1400	41.0	30.5	-	12.50	11.15
	P1DUC20V	G2FD042(S,H)21(T)	21	1400	40.5	30.5	-	12.50	10.95
	P1DUC20V	G2FD048(S,H)21	21	1460	41.0	30.9	-	12.25	11.05
	P1XDD20V	G2FD048(S,H)24	24	1365	41.5	31.9	-	12.80	11.35
	P1XUC16V	G1FA048S21	21	1400	41.0	30.5	-	12.50	11.15
	P1XUC16V	G2FD042(S,H)21(T)	21	1400	40.5	30.5	-	12.25	10.85
	P1XUC16V	G2FD048(S,H)21	21	1480	40.5	30.4	-	12.10	10.70
E2RC048S06	P1DUC20V	G1FA048S21(T)	21	1500	46.0	33.5	-	12.25	11.15
	P1DUC20V	G1FA060S21(T)(T)	21	1610	46.5	34.4	-	12.10	11.15
	P1DUC20V	G2FD048(S,H)21(T)	21	1610	45.5	33.3	-	12.10	10.90
	P1XDD20V	G2FD048(S,H)24(T)	24	1610	47.0	34.8	-	12.40	11.00
	P1XUC16V	G1FA048S21(T)	21	1480	45.5	33.0	-	12.10	10.90
	P1XUC16V	G1FA060S21(T)	21	1480	46.0	33.9	-	12.10	10.95
	P1XUC16V	G2FD048(S,H)21(T)	21	1480	45.0	32.8	-	12.10	10.65
	P1XUD20V	G1FA060S24(T)	24	1620	46.5	34.4	-	12.10	11.10
	P1XUD20V	G2FD060(S,H)24(T)	24	1620	46.5	34.4	-	12.20	11.10
E2RC060S06	P1DUC20V	G1FA060S21(T)	21	1730	57.5	40.4	-	12.10	10.80
	P1XDD20V	G2FD060(S,H)24(T)	24	1805	57.5	40.4	-	11.80	10.40
	P1XUC20V	G1FA060S21(T)	21	1620	57.0	39.9	-	12.10	10.70
	P1XUD20V	G1FA060S24(T)	24	1620	57.0	39.9	-	12.10	10.70
	P1XUD20V	G2FD060(S,H)24(T)	24	1620	57.0	39.9	-	12.10	10.70
	P1XUD20V	G2FD061H24	24	1620	58.5	43.5	-	12.10	10.55

1. G2FD coils available with a factory installed horizontal drain pan. See price pages for specific model number.
2. TXV = Use 1TV700 Series Kit.
3. Variable speed furnaces have B.O.D (Blower on Delay) standard.
4. A TXV is factory mounted in the Indoor Coil or Air Handler with model numbers containing a (T) suffix.

HEATING PERFORMANCE - With Air Handler

UNIT MODEL*	COIL ¹ MODEL	ARI HEATING ²							OUTDOOR TEMP ³									
		47°F			17°F			HSPF	-3°F		7°F		27°F		37°F		57°F	
		MBH	COP	KW	MBH	COP	KW		MBH	KW	MBH	KW	MBH	KW	MBH	KW	MBH	KW
E1RC018S06	F2RP/F2FP024	19.0	3.20	1.74	10.6	2.06	1.52	7.20	7.2	1.44	8.9	1.47	13.0	1.63	14.8	1.58	19.3	1.75
E1RC024S06	F2RP/F2FP030	24.0	3.16	2.23	14.0	2.06	2.00	7.30	9.1	1.75	1.3	1.86	15.8	2.08	21.1	2.13	27.1	2.32
E1RC030S06	F2RP/F2FP030	29.0	3.30	2.58	18.0	2.20	2.40	7.60	10.7	2.28	14.3	2.34	22.2	2.59	26.4	2.78	32.7	2.63
	F2RP/F2FP036	29.6	3.40	2.55	18.0	2.30	2.29	8.00	11.6	2.02	15.0	2.22	20.2	2.34	26.0	2.43	33.9	2.68
E1RC036S06	F2RP/F2FP036	35.0	3.50	2.93	20.6	2.30	2.62	8.00	12.1	2.26	15.9	2.40	25.0	2.86	30.8	2.79	39.6	3.12
	F2RP/F2FP042	35.0	3.50	2.93	20.6	2.30	2.62	8.00	12.1	2.26	15.9	2.40	25.0	2.86	30.8	2.79	39.6	3.12
E1RC042S06	F2RP/F2FP042	41.5	3.38	3.60	25.2	2.30	3.21	8.00	14.3	2.95	19.8	3.08	31.4	3.43	37.6	3.65	46.9	3.73
	F2FP048	42.0	3.60	3.42	25.4	2.38	3.14	8.00	14.8	2.93	20.1	3.04	30.9	3.24	36.7	3.33	48.8	3.54
E2RC048S06	F2FP045	47.0	3.22	4.28	29.4	2.40	3.59	8.00	17.7	3.13	23.5	3.36	33.7	3.71	37.9	3.78	52.9	4.39
	F2FP048	47.5	3.18	4.38	30.0	2.40	3.66	8.00	18.3	3.19	24.2	3.42	34.3	3.76	38.6	3.86	53.3	4.62
	F2FV060	46.0	3.34	4.04	28.4	2.54	3.28	8.25	16.7	2.77	22.5	3.02	32.7	3.40	37.0	3.52	51.9	4.29
E2RC060S06	F2FP060	59.0	3.40	5.08	35.2	2.30	4.41	7.75	19.3	3.96	27.3	4.18	38.8	4.45	42.5	4.49	66.9	5.31
	F2FV060	57.5	3.80	4.43	33.6	2.50	3.94	8.25	17.7	3.61	25.6	3.77	37.2	3.94	40.9	3.95	65.5	4.60

- Rated CFM same as for cooling.
- Heating MBH based on ARI standards of 70° DB entering indoor air, 72% RH outdoor air with 25 feet of interconnecting piping and no supplemental electric heat operation.
- Integrated heating capacities include the effect of defrost cycles in the temperature range where they occur.
CP equals MBH output divided by (total KW input x 3.412).
HSPF (Heating Seasonal Performance Factor) is the total heating output during a normal annual usage period for heating divided by the total electric power input during the same period.
— = Not Applicable.

HEATING PERFORMANCE - Furnace Coils

UNIT MODEL*	COIL ¹ MODEL	ARI HEATING ²							Variable Speed	OUTDOOR TEMP ³									
		47°F			17°F			HSPF		-3°F		7°F		27°F		37°F		57°F	
		MBH	COP	KW	MBH	COP	KW			STD	N1VS	MBH	KW	MBH	KW	MBH	KW	MBH	KW
E1RC018S06	G2FD024(S,H)14,17	18.8	3.40	1.65	10.6	2.04	1.52	7.0	7.1	7.2	1.44	8.9	1.47	13.0	1.63	14.8	1.58	19.3	1.71
	G1HA024H14(T)	18.4	3.40	1.65	10.2	2.04	1.52	7.0	--	7.2	1.44	8.9	1.47	13.0	1.63	14.8	1.58	19.3	1.71
	G1HD024	19.0	3.24	1.72	10.4	2.04	1.49	7.0	--	4.7	1.34	7.5	1.42	12.8	1.62	15.2	1.74	21.9	1.79
	G1NA030S17K	18.0	3.26	1.62	10.8	2.06	1.54	7.2	--	6.0	1.48	8.4	1.51	13.0	1.58	15.2	1.63	20.4	1.65
	G1UA024S14,17	18.8	3.14	1.75	10.4	2.02	1.50	7.0	--	5.0	1.33	7.7	1.42	13.1	1.59	15.8	1.67	21.8	1.84
	G1UA030S14	19.0	3.22	1.73	10.4	2.04	1.49	7.1	--	4.7	1.33	7.5	1.42	12.8	1.59	15.2	1.69	21.9	1.81
	G1FA024S14,17	18.8	3.14	1.75	10.4	2.02	1.50	7.0	--	5.0	1.33	7.7	1.42	13.1	1.59	15.8	1.67	21.8	1.84
G1FA030S14	19.0	3.22	1.73	10.4	2.04	1.49	7.1	--	4.7	1.33	7.5	1.42	12.8	1.59	15.2	1.69	21.9	1.81	
E1RC024S06	G2FD024(S,H)14,17	23.4	3.04	2.26	13.8	2.02	2.00	7.2	--	7.4	1.83	10.6	1.92	16.5	2.03	19.1	2.06	26.6	2.34
	G1HA024H14(T)	23.0	3.04	2.26	13.6	2.02	2.00	7.2	--	7.4	1.83	10.6	1.92	16.5	2.03	19.1	2.06	26.6	2.34
	G2FD030(S,H)14,17	23.6	3.12	2.22	14.0	2.06	1.99	7.3	7.3	7.9	1.81	11.0	1.90	17.8	2.08	20.3	2.60	27.7	2.31
	G2FD035(S,H)14	23.6	3.12	2.22	14.0	2.06	1.99	7.3	--	8.0	1.82	11.0	1.90	17.0	2.08	20.3	2.16	27.6	2.31
	G1HD024S	23.4	3.08	2.22	13.8	2.05	1.97	7.2	--	7.7	1.78	10.7	1.88	16.9	2.07	20.1	2.15	27.5	2.32
	G1HD036S	23.6	3.24	2.22	14.0	2.12	1.99	7.3	--	7.9	1.80	11.0	1.90	17.0	2.09	20.2	2.16	27.9	2.30
	G1NA030S17K	24.0	3.16	2.23	14.0	2.06	1.99	7.3	--	7.3	1.84	10.7	1.91	16.9	2.08	19.7	2.16	27.3	2.30
	G1NA030S21M	24.0	3.16	2.23	14.0	2.06	1.99	7.3	--	7.3	1.84	10.7	1.91	16.9	2.08	19.7	2.16	27.3	2.30
	G1UA030S14	23.6	3.12	2.22	14.0	2.06	1.99	7.3	--	7.9	1.81	11.0	1.90	17.0	2.08	20.3	2.16	27.7	2.34
	G1UA036S17,21	23.6	3.12	2.22	14.0	2.06	1.99	7.3	--	7.9	1.81	11.0	1.90	17.0	2.08	20.3	2.16	27.7	2.34
G1FA030S14	23.6	3.12	2.22	14.0	2.06	1.99	7.3	--	7.9	1.81	11.0	1.90	17.0	2.08	20.3	2.16	27.7	2.34	
G1FA036S17,21	23.6	3.12	2.22	14.0	2.06	1.99	7.3	--	7.9	1.81	11.0	1.90	17.0	2.08	20.3	2.16	27.7	2.34	
E1RC030S06	G2FD030(S,H)17	29.6	3.36	2.58	18.0	2.28	2.31	8.0	--	10.2	2.10	14.1	2.21	21.9	2.42	26.1	2.52	35.2	2.78
	G2FD035(S,H)14	29.6	3.36	2.58	18.0	2.28	2.31	8.0	--	10.2	2.10	14.1	2.21	21.9	2.42	26.1	2.52	35.2	2.78
	G2FD036(S,H)17	30.0	3.40	2.59	18.2	2.30	2.32	8.0	8.1	10.3	2.10	14.2	2.21	22.2	2.45	26.4	2.52	35.8	2.77
	G2FD036(S,H)21	29.6	3.38	2.55	18.0	2.28	2.32	8.0	--	10.5	2.13	14.4	2.22	22.0	2.41	26.1	2.50	35.1	2.74
	G1HA036H14(T)	29.0	3.38	2.55	17.6	2.28	2.32	7.9	--	10.5	2.13	14.4	2.22	22.0	2.41	26.1	2.50	35.1	2.74
	G1HD036S	30.0	3.50	2.51	18.2	2.34	2.27	8.0	--	10.3	2.07	14.2	2.17	22.2	2.37	26.4	2.46	35.7	2.70
	G1HD048S	30.4	3.54	2.51	18.4	2.36	2.27	8.0	--	10.3	2.08	14.3	2.17	22.3	2.37	26.6	2.46	36.1	2.68
	G1NA036S17L	29.6	3.40	2.55	18.0	2.30	2.29	8.0	--	10.3	2.12	14.1	2.21	21.3	2.34	24.6	2.39	33.5	2.64
	G1NA048S21D	29.6	3.40	2.55	18.0	2.30	2.29	8.0	--	10.3	2.12	14.1	2.21	21.3	2.34	24.6	2.39	33.5	2.64
	G1UA036S14	29.8	3.42	2.57	18.2	2.28	2.34	8.0	--	10.5	2.19	14.3	2.26	20.8	2.31	23.3	2.27	33.7	2.64
	G1UA036S17,21	29.6	3.36	2.58	18.0	2.28	2.31	8.0	--	10.2	2.10	14.1	2.21	21.9	2.42	26.1	2.52	35.2	2.78
	G1FA036S14	29.8	3.42	2.57	18.2	2.28	2.34	8.0	--	10.5	2.19	14.3	2.26	20.8	2.31	23.3	2.27	33.7	2.64
	G1FA036S17,21	29.6	3.36	2.58	18.0	2.28	2.31	8.0	--	10.2	2.10	14.1	2.21	21.9	2.42	26.1	2.52	35.2	2.78

For Notes see Page 10.

HEATING PERFORMANCE - Furnace Coils (Continued)

UNIT MODEL*	COIL ¹ MODEL	ARI HEATING ²							Variable Speed N1VS	OUTDOOR TEMP ³									
		47°F			17°F			HSPF		-3°F		7°F		27°F		37°F		57°F	
		MBH	COP	KW	MBH	COP	KW			STD	MBH	KW	MBH	KW	MBH	KW	MBH	KW	MBH
E1RC036S06	G2FD036(S,H)17	35.4	3.54	2.93	20.8	2.20	2.77	8.0	8.1	10.6	2.61	15.7	2.69	25.9	2.85	31.6	2.93	41.1	3.03
	G2FD036(S,H)21	35.0	3.46	2.96	20.4	2.16	2.77	7.8	--	10.1	2.56	15.2	2.66	25.6	2.87	31.2	2.96	40.7	3.14
	G2FD042(S,H)21	35.4	3.52	2.95	20.8	2.30	2.65	8.0	--	11.1	2.45	15.9	2.55	24.9	2.66	28.9	2.68	40.3	3.05
	G1HA036H17	34.6	3.52	2.95	20.4	2.30	2.65	7.9	--	11.1	2.45	15.9	2.55	24.9	2.66	28.9	2.68	40.3	3.05
	G1HD036S	35.4	3.56	2.91	20.8	2.20	2.76	8.0	--	10.4	2.58	15.6	2.67	26.0	2.85	31.6	2.92	41.2	3.07
	G1HD048S	35.4	3.58	2.89	20.8	2.22	2.75	8.0	--	10.4	2.58	15.6	2.66	26.0	2.83	31.7	2.90	41.2	3.04
	G1NA036S17L	36.0	3.50	3.01	20.6	2.30	2.62	8.0	--	10.3	2.37	15.5	2.49	24.5	2.70	28.4	2.78	41.1	3.14
	G1NA048S21D	36.0	3.50	3.01	20.6	2.30	2.62	8.0	--	10.3	2.37	15.5	2.49	24.5	2.70	28.4	2.78	41.1	3.14
G1UA048S21	35.8	3.58	2.93	20.8	2.32	2.63	8.0	--	0.4	2.37	15.6	2.50	26.0	2.76	31.9	2.88	41.6	3.07	
E1RC036S(25,46)	G1FA048(S,H)21	34.0	3.38	2.95	20.2	2.50	2.37	8.00		11.0	2.00	15.6	2.19	24.1	2.50	27.9	2.63	38.6	3.15
	G1UA048(S,H)21	34.0	3.38	2.95	20.2	2.50	2.37	8.00		11.0	2.00	15.6	2.19	24.1	2.50	27.9	2.63	38.6	3.15
	G1HA048H21	33.6	3.36	2.93	19.8	2.48	2.34	8.00		10.6	1.95	15.2	2.14	23.6	2.46	27.4	2.58	38.2	3.13
E1RC042S06	G2FD048(S,H)21,24	34.4	3.38	2.98	20.4	2.50	2.39	8.00		11.1	2.01	15.7	2.21	24.3	2.53	28.3	2.66	39.1	3.18
	G2FD042(S,H)21	41.5	3.42	3.56	25.2	2.32	3.18	8.0	--	14.5	2.90	19.9	3.04	30.5	3.32	36.3	3.45	48.1	3.71
	G2FD048(S,H)21,24	41.5	3.42	3.56	25.2	2.32	3.18	8.0	8.1	14.3	2.93	19.8	3.06	28.1	3.15	31.1	3.12	46.9	3.68
	G2FD060(S,H)24	42.0	3.58	3.44	25.4	2.36	3.15	8.0	--	14.3	2.96	19.9	3.06	29.7	3.31	34.1	3.47	47.5	3.53
	G1HA048H21	41.5	3.50	3.52	25.0	2.36	3.15	7.9	--	14.6	2.94	20.0	3.05	30.8	3.26	36.7	3.38	48.9	3.59
	G1HD048S	42.0	3.54	3.47	25.4	2.38	3.13	8.0	--	14.7	2.89	20.0	3.01	30.8	3.24	36.6	3.35	48.8	3.64
	G1NA048S21D	41.0	3.30	3.64	27.4	2.50	3.21	8.0	--	18.3	2.93	22.9	3.07	30.3	3.33	33.2	3.45	45.5	3.78
	G1UA048S21	42.0	3.50	3.52	25.4	2.36	3.15	8.0	--	14.6	2.94	20.0	3.05	30.8	3.26	36.7	3.38	48.9	3.59
G1FA048S21	42.0	3.50	3.52	25.4	2.36	3.15	8.0	--	14.6	2.94	20.0	3.05	30.8	3.26	36.7	3.38	48.9	3.59	
E2RC048S06	G2FD048(S,H)21,24	47.5	3.22	4.35	29.8	2.42	3.61	8.0	--	18.0	3.11	23.9	3.36	34.1	3.71	38.4	3.81	53.4	4.60
	G2FD060(S,H)24	47.5	3.16	4.04	29.6	2.38	3.28	8.0	8.2	16.7	2.77	22.5	3.02	32.7	3.40	37.0	3.52	51.9	4.29
	G2FD061H24	45.0	3.30	4.00	28.6	2.56	3.27	--	8.2	17.7	2.79	23.1	3.03	32.6	3.39	36.6	3.51	50.5	4.24
	G1HA048H21(T)	46.5	3.24	4.30	29.0	2.40	3.61	7.9	--	17.7	3.16	23.6	3.39	34.0	3.70	38.4	3.79	53.5	4.52
	G1HD060S	46.5	3.24	4.21	29.6	2.38	3.64	8.0	--	18.3	3.27	24.0	3.46	33.7	3.71	37.9	3.78	52.1	4.39
	G1NA042S24W	48.5	3.36	4.22	30.4	2.50	3.56	8.0	--	18.3	3.13	24.4	3.35	34.3	3.65	37.2	3.73	54.5	4.44
	G1UA048S21	47.5	3.24	4.30	29.6	2.40	3.61	8.0	--	17.7	3.16	23.6	3.39	34.0	3.70	38.4	3.79	53.5	4.52
	G1UA060S21,24	47.5	3.16	4.17	29.6	2.38	3.60	8.0	--	17.6	3.21	23.3	3.40	34.7	3.80	40.8	4.00	55.6	4.46
	G1FA048S21	47.5	3.24	4.30	29.6	2.40	3.61	8.0	--	17.7	3.16	23.6	3.39	34.0	3.70	38.4	3.79	53.5	4.52
G1FA060S21,24	47.5	3.16	4.17	29.6	2.38	3.60	8.0	--	17.6	3.21	23.3	3.40	34.7	3.80	40.8	4.00	55.6	4.46	
E1RC048S(25,46)	G1UA048(S,H)21	46.5	3.36	4.06	29.0	2.38	3.57	8.00		17.3	3.25	23.2	3.41	36.5	3.97	44.0	4.37	52.3	4.22
	G1UA060(S,H)21,24	47.0	3.40	4.05	29.4	2.40	3.59	8.00		17.5	3.34	23.4	3.46	36.7	3.97	44.2	4.36	52.9	4.05
	G1FA048(S,H)21	46.5	3.36	4.06	29.0	2.38	3.57	8.00		17.3	3.25	23.2	3.41	36.5	3.97	44.0	4.37	52.3	4.22
	G1FA060(S,H)21,24	47.0	3.40	4.05	29.4	2.40	3.59	8.00		17.5	3.34	23.4	3.46	36.7	3.97	44.2	4.36	52.9	4.05
	G1HA060H24	47.0	3.40	4.05	29.4	2.38	3.62	8.00		17.5	3.34	23.4	3.46	36.7	3.97	44.2	4.36	52.9	4.05
	G2FD048(S,H)21,24	47.0	3.38	4.08	29.2	2.40	3.57	8.00		17.3	3.23	23.3	3.40	36.6	3.97	44.1	4.37	52.9	4.24
	G2FD060(S,H)24	47.0	3.40	4.05	29.4	2.40	3.59	8.00		17.5	3.34	23.4	3.46	36.7	3.97	44.2	4.36	52.9	4.05
E2RC060S06	G2FD060(S,H)24	58.5	3.50	4.90	34.8	2.40	4.25	8.0	8.3	19.0	3.82	26.9	4.03	38.6	4.31	42.3	4.36	66.4	5.11
	G2FD061H24	59.5	3.50	4.98	35.6	2.40	4.31	8.0	8.1	19.7	3.86	27.6	4.09	39.2	4.35	42.9	4.39	67.5	5.21
	G1HA060H24(T)	57.5	3.50	4.90	34.8	2.40	4.25	8.0	--	19.0	3.82	26.9	4.03	38.6	4.31	42.3	4.36	66.4	5.11
	G1HD060S	59.0	3.50	4.90	35.0	2.40	4.28	8.0	--	19.0	3.88	29.9	4.08	38.4	4.33	42.1	4.37	66.4	5.10
	G1NA060S24T	58.5	3.38	5.07	35.0	2.40	4.27	7.8	--	19.3	3.74	27.2	4.01	38.6	4.35	42.2	4.43	66.3	5.34
	G1UA060S21,24	58.5	3.50	4.90	34.8	2.40	4.25	8.0	--	19.0	3.82	26.9	4.03	38.6	4.31	42.3	4.36	66.4	5.11
	G1FA060S21,24	58.5	3.50	4.90	34.8	2.40	4.25	8.0	--	19.0	3.82	26.9	4.03	38.6	4.31	42.3	4.36	66.4	5.11
E1RC060S(25,46)	G1UA060(S,H)21,24	59.0	3.48	4.97	37.0	2.92	3.72	8.00		22.3	3.86	30.0	4.08	40.4	4.32	43.8	4.33	66.3	5.19
	G1FA060(S,H)21,24	59.0	3.48	4.97	37.0	2.92	3.72	8.00		22.3	3.86	30.0	4.08	40.4	4.32	43.8	4.33	66.3	5.19
	G1HA060H24	58.5	3.48	4.93	36.6	2.92	3.68	8.00		22.0	3.81	29.3	4.03	40.0	4.27	43.4	4.29	65.8	5.15
	G2FD060(S,H)24	59.0	3.48	4.97	37.0	2.92	3.72	8.00		22.3	3.86	30.0	4.08	40.4	4.32	43.8	4.33	66.3	5.19

1. Rated CFM same as for cooling.
 2. Heating MBH based on ARI standards of 70° DB entering indoor air, 72% RH outdoor air with 25 feet of interconnecting piping and no supplemental electric heat operation.
 3. Integrated heating capacities include the effect of defrost cycles in the temperature range where they occur.
 CP equals MBH output divided by (total KW input x 3.412).
 HSPF (Heating Seasonal Performance Factor) is the total heating output during a normal annual usage period for heating divided by the total electric power input during the same period.
 -- = Not Applicable.

HEATING PERFORMANCE - With Variable Speed Furnaces

UNIT MODEL	FURNACE	COIL ¹ MODEL	ARI HEATING ²							OUTDOOR TEMP ³									
			47°F			17°F			HSP F	-3°F		7°F		27°F		37°F		57°F	
			MBH	COP	KW	MBH	COP	KW	STD	MBH	KW	MBH	KW	MBH	KW	MBH	KW	MBH	KW
E1RC018S06	P1DUA12V	G1FA024S14	18.4	3.32	1.62	10.0	2.12	1.38	7.50	4.6	1.29	7.3	1.37	12.7	1.46	15.4	1.54	21.4	1.62
	P1DUA12V	G1FA030S14	18.5	3.40	1.60	9.8	2.16	1.33	7.45	4.2	1.29	7.1	1.36	12.3	1.46	14.7	1.56	21.4	1.60
	P1DUA12V	G2FD024(S,H)14	18.3	3.62	1.49	10.0	2.16	1.36	7.50	6.7	1.34	8.4	1.39	12.5	1.50	14.3	1.45	18.8	1.52
	P1XDB12V	G2FD024(S,H)17	18.3	3.40	1.58	11.2	2.26	1.45	7.00	6.7	1.32	8.4	1.37	12.5	1.48	14.3	1.43	18.8	1.50
	P1XUB12V	G1FA024S17	18.4	3.32	1.62	10.0	2.12	1.38	7.50	4.6	1.29	7.3	1.37	12.7	1.46	15.4	1.54	21.4	1.62
	P1XUB12V	G2FD024(S,H)17	18.3	3.62	1.49	10.0	2.14	1.37	7.50	6.7	1.34	8.4	1.39	12.5	1.50	14.3	1.45	18.8	1.52
E1RC024S06	P1DUA12V	G1FA030S14	23.0	3.16	2.13	13.4	2.10	1.87	7.50	7.5	1.77	10.6	1.86	16.6	1.95	19.9	2.03	27.3	2.09
	P1DUA12V	G2FD024(S,H)14	23.0	3.16	2.13	13.4	2.10	1.87	7.50	7.0	1.79	10.2	1.87	16.1	1.90	18.7	1.93	26.2	2.13
	P1DUB16V	G1FA036S17	23.2	3.26	2.08	13.6	2.14	1.86	7.60	7.5	1.77	10.6	1.86	16.6	1.95	19.9	2.03	27.3	2.09
	P1DUB16V	G2FD024(S,H)17	23.0	3.16	2.13	13.4	2.10	1.87	7.50	7.0	1.79	10.2	1.87	16.1	1.90	18.7	1.93	26.2	2.13
	P1DUB16V	G2FD030(S,H)17	23.2	3.26	2.08	13.6	2.14	1.86	7.60	7.5	1.77	10.6	1.86	17.4	1.95	19.9	2.03	27.3	2.09
	P1XDB12V	G2FD024(S,H)17	22.9	3.20	2.10	13.0	2.06	1.85	7.20	6.9	1.77	10.1	1.85	16.0	1.88	18.6	1.91	26.1	2.11
	P1XDB12V	G2FD030(S,H)17	23.0	3.28	2.06	13.2	2.10	1.84	7.30	7.3	1.74	10.4	1.83	17.2	1.92	19.7	2.00	27.1	2.06
	P1XUB12V	G1FA036S17	23.1	3.28	2.06	13.4	2.16	1.82	7.60	7.4	1.74	10.5	1.83	16.5	1.92	19.8	2.00	27.2	2.06
	P1XUB12V	G2FD024(S,H)17	22.9	3.20	2.10	13.2	2.10	1.84	7.50	6.9	1.77	10.1	1.85	16.0	1.88	18.6	1.91	26.1	2.11
E1RC030S06	P1DUA12V	G1FA036S14	29.5	3.52	2.46	17.8	2.34	2.23	8.30	10.2	2.17	14.0	2.25	20.5	2.22	23.0	2.18	33.4	2.48
	P1DUA12V	G2FD035(S,H)14	29.1	3.50	2.44	17.4	2.38	2.14	8.30	9.7	2.06	13.6	2.16	21.4	2.27	25.6	2.37	34.7	2.43
	P1DUB16V	G1FA036S17	29.0	3.54	2.40	17.4	2.38	2.14	8.35	9.6	2.04	13.5	2.14	21.3	2.25	25.5	2.35	34.6	2.41
	P1DUB16V	G2FD036(S,H)17	29.4	3.58	2.41	17.6	2.42	2.13	8.45	9.7	2.03	13.6	2.14	21.6	2.27	25.8	2.34	35.2	2.41
	P1DXUB12V	G1FA036S17	29.0	3.54	2.40	17.4	2.38	2.14	8.30	9.6	2.04	13.5	2.14	21.3	2.25	25.5	2.35	34.6	2.41
	P1DXUB12V	G2FD030(S,H)17	29.0	3.54	2.40	17.4	2.38	2.14	8.30	9.6	2.04	13.5	2.14	21.3	2.25	25.5	2.35	34.6	2.41
	P1DXUB12V	G2FD036(S,H)17	29.4	3.58	2.41	17.6	2.42	2.13	8.35	9.7	2.03	13.6	2.14	21.6	2.27	25.8	2.34	35.2	2.41
	P1XDB12V	G2FD036(S,H)17	29.6	3.50	2.48	17.8	2.34	2.23	8.00	9.8	2.11	13.7	2.21	21.5	2.32	25.7	2.42	34.8	2.48
E1RC036S06	P1DUB16V	G2FD036(S,H)17	34.9	3.68	2.78	20.2	2.26	2.62	8.20	10.1	2.55	15.2	2.63	25.4	2.71	31.1	2.79	40.6	2.79
	P1DUC20V	G1FA048S21	35.1	3.78	2.72	20.0	2.44	2.40	8.30	9.7	2.30	14.9	2.43	25.3	2.56	31.2	2.68	40.9	2.73
	P1DUC20V	G2FD036(S,H)21	34.4	3.62	2.78	19.8	2.24	2.59	8.10	9.5	2.48	14.6	2.59	25.0	2.69	30.6	2.78	40.1	2.78
	P1DUC20V	G2FD042(S,H)21	34.4	3.64	2.77	19.6	2.24	2.56	8.10	9.5	2.47	14.6	2.58	25.0	2.68	30.6	2.77	40.1	2.77
	P1XDB12V	G2FD036(S,H)17	35.0	3.50	2.93	19.8	2.30	2.52	8.00	10.2	2.56	15.3	2.64	25.5	2.72	31.2	2.80	40.7	2.80
	P1XUB12V	G2FD036(S,H)17	35.1	3.64	2.82	20.4	2.24	2.67	8.25	10.3	2.59	15.4	2.67	25.6	2.75	31.3	2.83	40.8	2.83
	P1XUC16V	G1FA048S21	35.3	3.74	2.76	20.2	2.40	2.47	8.30	9.9	2.34	15.1	2.47	25.5	2.60	31.4	2.72	41.1	2.77
	P1XUC16V	G2FD036(S,H)21	34.5	3.60	2.81	19.8	2.24	2.59	8.10	9.6	2.51	14.7	2.62	25.1	2.72	30.7	2.81	40.2	2.81
E1RC042S06	P1DUC20V	G1FA048S21	41.5	3.60	3.38	24.8	2.40	3.03	8.50	14.1	2.91	19.5	3.01	30.3	3.12	36.2	3.24	48.4	3.38
	P1DUC20V	G2FD042(S,H)21	41.0	3.52	3.42	24.6	2.38	3.03	8.40	14.0	2.90	19.4	3.04	30.0	3.18	35.8	3.31	47.6	3.42
	P1DUC20V	G2FD048(S,H)21	41.7	3.58	3.41	25.0	2.40	3.05	8.25	14.0	2.96	19.5	3.08	27.8	3.05	30.8	3.02	46.6	3.46
	P1XDD20V	G2FD048(S,H)24	-0.5	3.48	0.04	27.2	2.70	2.95	8.00	13.8	2.91	19.3	3.03	27.6	3.00	30.6	2.97	46.4	3.41
	P1XUC16V	G1FA048S21	41.6	3.60	3.38	25.0	2.42	3.03	8.40	14.2	2.92	19.6	3.02	30.4	3.13	36.3	3.25	48.5	3.39
	P1XUC16V	G2FD042(S,H)21	41.2	3.50	3.45	24.8	2.36	3.08	8.25	14.2	2.94	19.6	3.08	30.2	3.22	36.0	3.35	47.8	3.46
	P1XUC16V	G2FD048(S,H)21	42.0	3.52	3.49	25.4	2.38	3.13	8.15	14.3	3.05	19.8	3.17	28.1	3.14	31.1	3.11	46.9	3.55
E2RC048S06	P1DUC20V	G1FA048S21	47.2	3.30	4.19	29.2	2.44	3.51	8.20	17.4	3.29	23.3	3.51	33.7	3.60	38.1	3.69	53.2	4.20
	P1DUC20V	G1FA060S21	47.3	3.20	4.33	29.4	2.42	3.56	8.15	17.4	3.33	23.1	3.53	34.5	3.73	40.6	3.93	55.4	4.10
	P1DUC20V	G2FD048(S,H)21	47.3	3.26	4.25	29.6	2.44	3.55	8.15	17.8	3.31	23.7	3.56	33.9	3.66	38.2	3.76	53.2	4.30
	P1XDD20V	G2FD048(S,H)24	47.4	7.95	1.75	29.4	2.38	3.62	7.95	17.9	3.33	23.8	3.58	34.0	3.68	38.3	3.78	53.3	4.32
	P1XUC16V	G1FA048S21	47.4	3.26	4.26	29.4	2.42	3.56	8.15	17.6	3.36	23.5	3.58	33.9	3.67	38.3	3.76	53.4	4.27
	P1XUC16V	G1FA060S21	47.3	3.18	4.35	29.0	2.38	3.57	8.05	17.4	3.33	23.1	3.53	34.5	3.73	40.6	3.93	55.4	4.10
	P1XUC16V	G2FD048(S,H)21	47.3	3.24	4.27	29.2	2.42	3.54	8.10	17.8	3.29	23.7	3.54	33.9	3.64	38.2	3.74	53.2	4.28
	P1XUD20V	G1FA060S24	47.3	3.20	4.33	29.4	2.40	3.59	8.10	17.4	3.35	23.1	3.55	34.5	3.75	40.6	3.95	55.4	4.12
	P1XUD20V	G2FD060(S,H)24	47.3	3.20	4.33	29.4	2.40	3.59	8.10	17.4	3.35	23.1	3.55	34.5	3.75	40.6	3.95	55.4	4.12

For Notes see Page 12.

HEATING PERFORMANCE - With Variable Speed Furnaces (Continued)

UNIT MODEL	FURNACE	COIL ¹ MODEL	ARI HEATING ²							OUTDOOR TEMP ³									
			47°F			17°F			HSP F	-3°F		7°F		27°F		37°F		57°F	
			MBH	COP	KW	MBH	COP	KW	STD	MBH	KW	MBH	KW	MBH	KW	MBH	KW	MBH	KW
E2RC060S06	P1DUC20V	G1FA060S21	58.4	3.52	4.86	34.6	2.42	4.19	8.05	18.9	4.00	26.8	4.22	38.5	4.28	42.2	4.33	66.3	4.87
	P1XDD20V	G2FD060(S,H)24	59.2	8.00	2.17	35.4	2.34	4.43	8.00	19.7	4.25	27.6	4.47	39.3	4.53	43.0	4.58	67.1	5.12
	P1XUC20V	G1FA060S21	58.1	3.56	4.78	34.4	2.44	4.13	8.10	18.6	3.92	26.5	4.14	38.2	4.20	41.9	4.25	66.0	4.79
	P1XUD20V	G1FA060S24	58.1	3.56	4.78	34.4	2.44	4.13	8.10	18.6	3.92	26.5	4.14	38.2	4.20	41.9	4.25	66.0	4.79
	P1XUD20V	G2FD060(S,H)24	58.1	3.56	4.78	34.4	2.44	4.13	8.10	18.6	3.92	26.5	4.14	38.2	4.20	41.9	4.25	66.0	4.79
	P1XUD20V	G2FD061H24	58.7	3.62	4.76	34.6	2.44	4.15	8.25	18.9	3.87	26.8	4.09	38.4	4.13	42.1	4.17	66.7	4.76

1. Rated CFM same as for cooling.
2. Heating MBH based on ARI standards of 70° DB entering indoor air, 72% RH outdoor air with 25 feet of interconnecting piping and no supplemental electric heat operation.
3. Integrated heating capacities include the effect of defrost cycles in the temperature range where they occur.
 CP equals MBH output divided by (total KW input x 3.412).
 HSPF (Heating Seasonal Performance Factor) is the total heating output during a normal annual usage period for heating divided by the total electric power input during the same period.
 — = Not Applicable.

ACCESSORIES

Refer to Price Manual for specific model numbers.

Start Assist Kit (2SA067*)

Blower Time Delay - Available to increase efficiency when installed. Installs on indoor section and maintains blower for approximately one minute after cooling thermostat has been satisfied.

Hard Start Kits - Provides required starting torque for use with Thermal Expansion Valve Kit.

Low Temperature Cutout (2LT06700224) - Prevents heat pump operation below -10°F ambient temperature.

Compressor Blanket - Designed to further reduce the normal operating sound.

Add-on Fossil Fuel Control - Interface controls for use with gas, oil furnaces and the heat pump system are available.

Thermal Expansion Valve Kit - 1TV0700 Series TXV kit used to improve system performance.

Outdoor Thermostat (2TD06700124) - Provides additional staging of supplemental electric heat.

Room Thermostats - A wide selection of matching thermostats is available to provide features required for any installation.

2H/1C, manual change-over electronic non-programmable thermostat.

3H/2C, non-programmable digital thermostat.

3H/2C, auto/manual changeover, electronic programmable, 7-day, hardwire thermostat.

* For the most current accessory information, refer to the price book or consult factory.

SOUND RATINGS

UNIT MODEL	SOUND RATINGS DECIBELS
018	80
024	80
030	80
036	80
042	80
048	80
060	80

*Rated in accordance with ARI Standard 270.

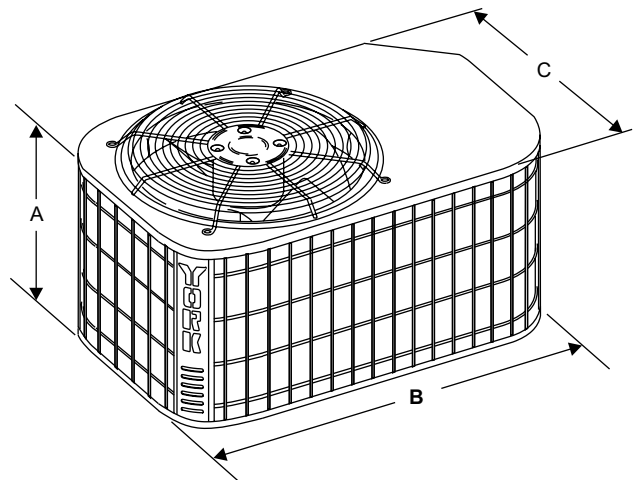

All dimensions are in inches. They are subject to change without notice. Certified dimensions will be provided upon request.

UNIT MODEL	DIMENSIONS (INCHES)			REFRIGERANT CONNECTION LINE SIZE	
	A ¹	B	C	Liquid	Vapor
018	25	35	23	3/8"	3/4"
024	27	37	27		
030	27	37	27		
036	33	37	27		7/8"
042	33	37	27		
048	32	43	32		
060	32	43	32	7/8" ²	1-1/8" ²

1. Including Fan Guard.
2. Three-phase uses 7/8". Single-phase uses 1-1/8".

TYPICAL INSTALLATION - DRHS018 THRU 060

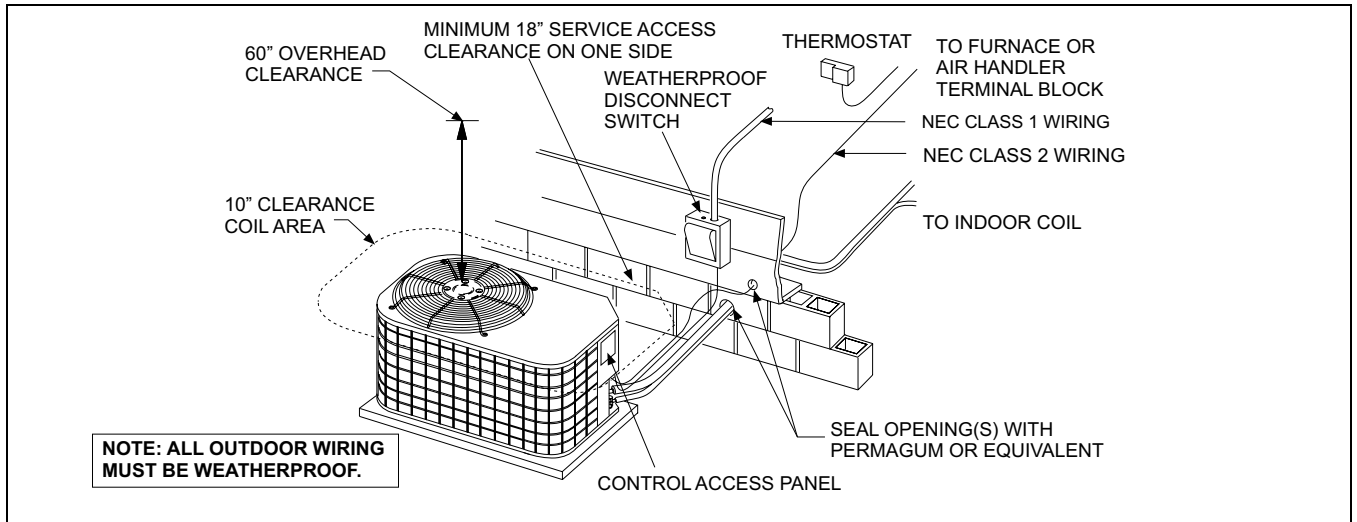

TYPICAL FIELD WIRING - 1 Phase Application

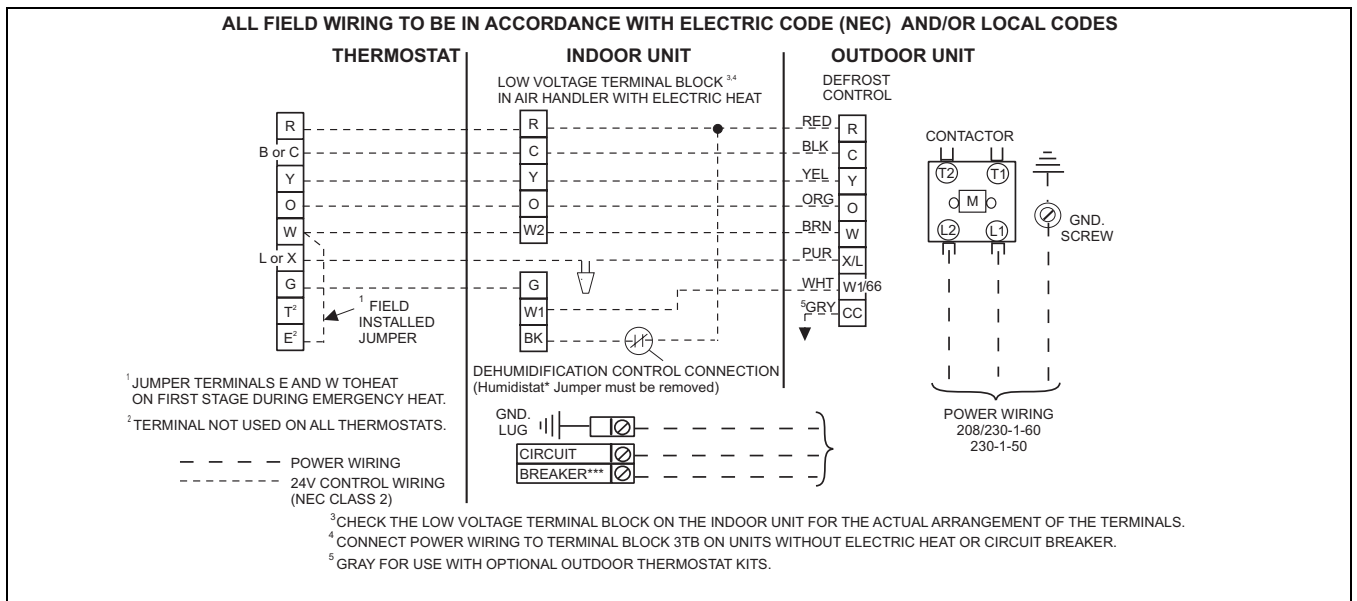

TYPICAL FIELD WIRING - 3 Phase Application

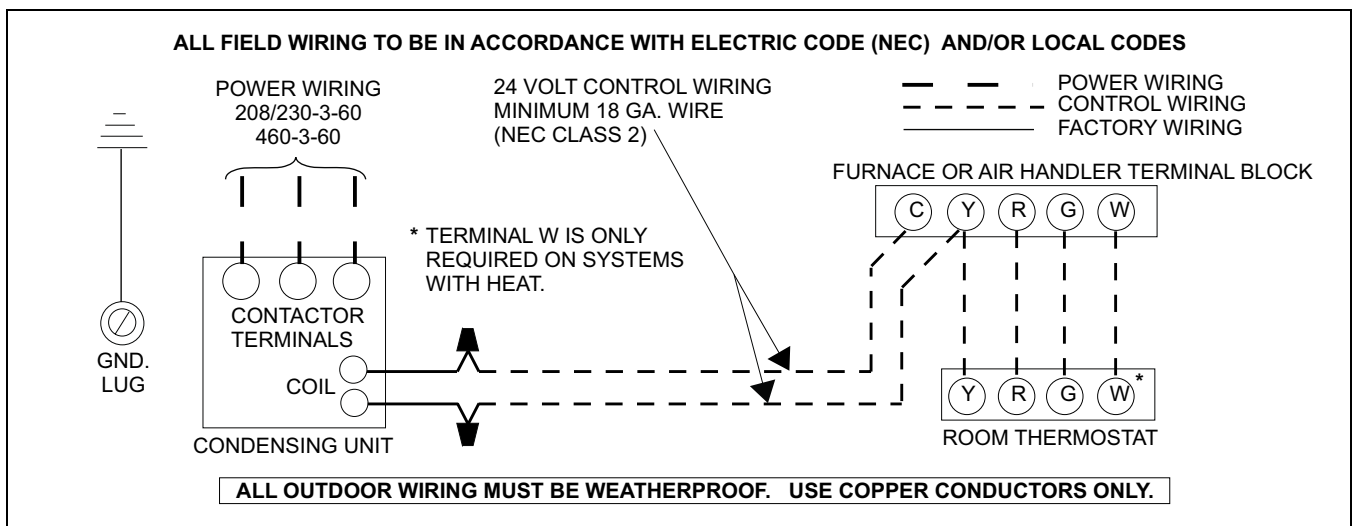

COOLING PERFORMANCE DATA										
AIR CONDITIONER MODEL NO.		E1RC018S06								
INDOOR COIL MODEL NO.		F2RP/F2FP024								
CONDENSER ENTERING AIR TEMPERATURE	D CFM	500			650			800		
	ID DB (°F)	85	80	70	85	80	70	85	80	70
	ID WB (°F)	72	67	57	72	67	57	72	67	57
75	T.C.	21.0	19.0	17.5	21.4	19.8	18.3	21.9	20.6	19.2
	S.C.	12.7	12.1	11.3	13.9	13.7	13.1	15.2	15.4	14.8
	KW	1.49	1.45	1.44	1.55	1.52	1.50	1.59	1.57	1.55
85	T.C.	20.2	18.0	16.3	20.9	18.9	17.2	21.7	19.8	18.0
	S.C.	12.4	11.6	10.8	14.0	13.5	12.5	15.6	15.5	14.2
	KW	1.58	1.55	1.52	1.65	1.61	1.59	1.70	1.67	1.64
95	T.C.	19.3	17.0	15.1	20.4	18.0	16.0	21.6	19.0	16.8
	S.C.	12.1	11.1	10.3	14.0	13.3	11.9	16.0	15.5	13.5
	KW	1.68	1.64	1.61	1.75	1.71	1.67	1.81	1.76	1.73
105	T.C.	17.7	15.5	13.5	18.8	16.4	15.2	19.8	17.3	16.9
	S.C.	11.5	10.4	9.6	13.4	12.4	11.0	15.3	14.4	12.4
	KW	1.76	1.71	1.69	1.83	1.78	1.75	1.89	1.84	1.81
115	T.C.	16.2	14.1	11.9	17.1	14.8	14.5	18.0	15.6	17.0
	S.C.	10.9	9.8	8.9	12.8	11.5	10.2	14.7	13.2	11.4
	KW	1.84	1.78	1.77	1.91	1.85	1.83	1.97	1.91	1.89
125	T.C.	14.6	12.6	10.4	15.4	13.3	13.7	16.3	13.9	17.1
	S.C.	10.3	9.2	8.2	12.1	10.6	9.3	14.0	12.1	10.4
	KW	1.92	1.85	1.85	1.99	1.92	1.91	2.05	1.98	1.97

NOTE: ALL CAPACITIES INCLUDE INDOOR FAN HEAT AT 1250 BTUH/1000 CFM.

Multipliers for determining the performance with other indoor sections.

NOTE: For dry bulb temperatures different than those listed (between 73-87 F), sensible capacity increases by 1060 BTUH per 1000 CFM per degree above the listed temperature and decreases by 1060 BTUH per 1000 CFM per degree below the listed temperature.

Air Handler	Coil	T.C.	S.C.	KW
N1AHB0806	G2FD024(S,H)17	0.99	0.96	1.00
N1VSB12	G2FD024(S,H)17	1.02	0.96	0.91
	G1FA024S14,17	0.98	0.98	1.00
	G1FA030S14	0.99	0.99	1.00
	G1HD024	1.00	0.92	1.00
	G1NA030S17K	1.00	0.92	1.00
	G1UA024S14,17	0.98	0.98	1.00
	G1UA030S14	0.99	0.99	1.00
	G2FD024(S,H)14,17	0.99	0.96	1.00
	G1HA024H14	0.97	0.94	0.98

Variable Speed Furnace	Coil	T.C.	S.C.	KW
P1DUA12V	G1FA024S14	1.00	1.01	0.92
P1DUA12V	G1FA030S14	1.01	1.02	0.92
P1DUA12V	G2FD024(S,H)14	1.01	0.99	0.92
P1XDB12V	G2FD024(S,H)17	1.01	0.99	0.90
P1XUB12V	G1FA024S17	1.00	1.01	0.92
P1XUB12V	G2FD024(S,H)17	1.01	0.99	0.92

COOLING PERFORMANCE DATA													
AIR CONDITIONER MODEL NO.		E1RC024S06											
INDOOR COIL MODEL NO.		F2RP/F2FP030											
CONDENSER ENTERING AIR TEMPERATURE	ID CFM	700				850				1000			
	ID DB (°F)	85	80	75	70	85	80	75	70	85	80	75	70
	ID WB (°F)	72	67	62	57	72	67	62	57	72	67	62	57
75	T.C.	27.7	25.3	23.3	20.9	28.1	25.8	23.8	21.3	28.3	25.9	24.0	21.5
	S.C.	16.6	16.5	15.9	16.7	17.4	17.5	16.8	17.7	17.8	17.9	17.2	18.1
	KW	1.90	1.89	1.89	1.85	1.95	1.94	1.94	1.91	2.00	2.00	1.99	1.96
85	T.C.	27.1	24.8	22.8	20.4	27.6	25.3	23.3	21.1	27.8	25.4	23.4	21.3
	S.C.	16.7	16.7	16.1	16.9	17.7	17.8	17.1	18.2	18.2	18.3	17.6	18.7
	KW	2.05	2.03	2.01	1.97	2.11	2.09	2.07	2.03	2.16	2.14	2.12	2.09
95	T.C.	25.5	23.3	21.4	19.2	25.9	23.6	21.7	19.6	26.0	23.7	22.0	19.8
	S.C.	16.4	16.4	15.8	16.6	17.6	17.5	16.9	17.7	18.0	18.0	17.5	18.3
	KW	2.22	2.19	2.16	2.11	2.28	2.25	2.22	2.17	2.33	2.30	2.28	2.23
105	T.C.	23.4	21.4	19.6	17.6	23.7	21.6	20.0	17.9	23.8	21.8	20.2	18.3
	S.C.	15.8	15.8	15.2	15.9	17.0	17.0	16.3	17.0	17.6	17.6	16.9	17.6
	KW	2.39	2.35	2.31	2.25	2.45	2.41	2.38	2.31	2.50	2.47	2.43	2.38
115	T.C.	21.3	19.4	17.9	15.9	21.5	19.7	18.2	16.6	21.7	19.9	18.3	16.8
	S.C.	15.1	15.1	14.5	15.1	16.3	16.3	15.5	15.9	17.0	16.8	16.0	16.1
	KW	2.56	2.51	2.46	2.39	2.62	2.57	2.52	2.46	2.68	2.63	2.58	2.53
125	T.C.	19.2	17.4	16.1	14.2	19.3	17.8	16.3	15.3	19.6	18.0	16.3	15.3
	S.C.	14.4	14.4	13.7	14.3	15.6	15.6	14.8	14.8	16.4	16.0	15.1	14.6
	KW	2.73	2.67	2.61	2.53	2.79	2.73	2.66	2.61	2.86	2.79	2.73	2.68

NOTE: ALL CAPACITIES INCLUDE INDOOR FAN HEAT AT 1250 BTUH/1000 CFM.

Multipliers for determining the performance with other indoor sections.

NOTE: For dry bulb temperatures different than those listed (between 73-87 F), sensible capacity increases by 1060 BTUH per 1000 CFM per degree above the listed temperature and decreases by 1060 BTUH per 1000 CFM per degree below the listed temperature.

Air Handler	Coil	T.C.	S.C.	KW
N1AHB0806	G2FD024(S,H)17	0.99	0.99	1.02
N1AHB0806	G2FD030(S,H)17	1.01	1.01	1.02
N1VSB12	G2FD030(S,H)17	1.03	1.01	0.94
	G1FA030S14	0.99	0.99	1.02
	G1FA036S17,21	1.01	1.01	1.02
	G1HD024	1.01	1.07	1.02
	G1HD036	1.03	1.09	1.03
	G1NA030S17K	1.00	0.97	1.00
	G1NA030S21M	1.00	0.97	1.00
	G1UA030S14	0.99	0.99	1.02
	G1UA036S17,21	1.01	1.01	1.02
	G2FD024(S,H)14,17	0.99	0.99	1.02
	G2FD030(S,H)17	1.01	1.01	1.02
	G2FD035(S,H)14	1.01	1.01	1.02
	G1HA024H14	0.97	0.97	1.00

Variable Speed Furnace	Coil	T.C.	S.C.	KW
P1DUA12V	G1FA030S14	1.01	1.01	0.96
P1DUA12V	G2FD024(S,H)14	1.01	1.01	0.96
P1DUB16V	G1FA036S17	1.03	1.03	0.96
P1DUB16V	G2FD024(S,H)17	1.01	1.01	0.96
P1DUB16V	G2FD030(S,H)17	1.03	1.03	0.97
P1XDB12V	G2FD024(S,H)17	1.00	1.00	0.93
P1XDB12V	G2FD030(S,H)17	1.03	1.03	0.93
P1XUB12V	G1FA036S17	1.03	1.04	0.96
P1XUB12V	G2FD024(S,H)17	1.02	1.02	0.95
P1XUB12V	G2FD030(S,H)17	1.03	1.04	0.96

COOLING PERFORMANCE DATA										
AIR CONDITIONER MODEL NO.		E1RC030S06								
INDOOR COIL MODEL NO.		F2RP/F2FP036								
CONDENSER ENTERING AIR TEMPERATURE	ID CFM	800			1000			1200		
	ID DB (°F)	85	80	70	85	80	70	85	80	70
	ID WB (°F)	72	67	57	72	67	57	72	67	57
75	T.C.	32.2	30.6	28.5	32.6	31.4	30.0	32.9	31.8	30.4
	S.C.	20.3	20.0	19.0	21.3	21.2	21.5	22.0	22.2	22.8
	KW	2.32	2.32	2.30	2.40	2.40	2.38	2.52	2.52	2.51
85	T.C.	31.2	28.9	26.0	32.2	30.0	27.5	32.6	30.8	28.3
	S.C.	20.1	19.3	18.0	22.0	21.2	20.5	23.2	22.9	22.2
	KW	2.48	2.46	2.43	2.57	2.55	2.52	2.70	2.68	2.65
95	T.C.	30.2	27.1	23.4	31.7	28.6	24.9	32.3	29.9	26.1
	S.C.	19.9	18.7	17.0	22.8	21.2	19.5	24.5	23.6	21.6
	KW	2.64	2.60	2.56	2.74	2.70	2.65	2.87	2.84	2.79
105	T.C.	27.6	24.4	21.5	29.1	25.8	22.7	29.9	26.9	23.5
	S.C.	18.9	17.7	15.9	21.8	20.2	18.5	23.8	22.5	20.4
	KW	2.79	2.75	2.70	2.89	2.84	2.79	3.03	2.98	2.93
115	T.C.	25.0	21.7	19.5	26.5	23.0	20.5	27.5	24.0	20.9
	S.C.	18.0	16.7	14.8	20.9	19.2	17.5	23.1	21.3	19.2
	KW	2.93	2.89	2.84	3.04	2.98	2.93	3.19	3.12	3.08
125	T.C.	22.3	19.1	17.6	23.9	20.2	18.2	25.2	21.1	18.4
	S.C.	17.0	15.8	13.7	19.9	18.2	16.5	22.4	20.2	18.0
	KW	3.07	3.03	2.98	3.19	3.12	3.07	3.35	3.26	3.23

NOTE: ALL CAPACITIES INCLUDE INDOOR FAN HEAT AT 1250 BTUH/1000 CFM.

Multipliers for determining the performance with other indoor sections.

NOTE: For dry bulb temperatures different than those listed (between 73-87 F), sensible capacity increases by 1060 BTUH per 1000 CFM per degree above the listed temperature and decreases by 1060 BTUH per 1000 CFM per degree below the listed temperature.

Air Handler	Coil	T.C.	S.C.	KW
N1AHB1206	G2FD036(S,H)17	0.98	0.98	1.01
N1VSB12	G2FD036(S,H)17	1.00	0.98	0.95
F2RP/F2FP030		0.97	0.97	1.01
	G1FA036S14	0.99	0.96	1.01
	G1FA036S17,21	0.97	0.97	1.01
	G1HD036	0.99	1.06	1.01
	G1HD048	1.03	1.10	1.02
	G1NA036S17L	1.05	0.98	1.02
	G1NA048S21D	1.05	0.98	1.02
	G1UA036S14	0.99	0.96	1.01
	G1UA036S17,21	0.97	0.97	1.01
	G2FD030(S,H)17	0.97	0.97	1.01
	G2FD035(S,H)14	0.97	0.97	1.01
	G2FD036(S,H)17	0.98	0.98	1.01
	G2FD036(S,H)21	0.98	0.98	0.98
	G1HA036H14	0.96	0.96	0.96

Variable Speed Furnace	Coil	T.C.	S.C.	KW
P1DUA12V	G1FA036S14	1.00	0.98	0.98
P1DUA12V	G2FD035(S,H)14	0.99	0.99	0.95
P1DUB16V	G1FA036S17	0.99	1.00	0.94
P1DUB16V	G2FD036(S,H)17	1.00	1.00	0.94
P1XUB12V	G1FA036S17	0.98	0.99	0.96
P1XUB12V	G2FD030(S,H)17	0.98	0.99	0.96
P1XUB12V	G2FD036(S,H)17	0.99	0.99	0.96
P1XDB12V	G2FD036(S,H)17	0.99	0.99	0.96

COOLING PERFORMANCE DATA										
AIR CONDITIONER MODEL NO.		E1RC036S06								
INDOOR COIL MODEL NO.		F2RP/F2FP036								
CONDENSER ENTERING AIR TEMPERATURE	ID CFM	1000			1200			1400		
	ID DB (°F)	85	80	70	85	80	70	85	80	70
	ID WB (°F)	72	67	57	72	67	57	72	67	57
75	T.C.	38.3	36.4	34.5	38.5	36.7	35.1	38.8	37.0	35.7
	S.C.	23.5	23.4	23.4	24.5	24.5	25.1	25.5	25.6	26.8
	KW	2.85	2.83	2.80	2.91	2.89	2.86	3.03	3.01	3.00
85	T.C.	37.0	34.7	31.8	37.6	35.3	32.6	38.2	36.0	33.5
	S.C.	23.9	23.2	22.3	25.5	24.8	24.2	27.2	26.5	26.2
	KW	3.06	3.02	2.98	3.07	3.03	2.99	3.26	3.21	3.17
95	T.C.	35.7	33.0	29.1	36.6	34.0	30.1	37.5	35.0	31.2
	S.C.	24.3	22.9	21.2	26.6	25.2	23.4	28.9	27.4	25.6
	KW	3.27	3.20	3.15	3.34	3.27	3.22	3.48	3.41	3.35
105	T.C.	33.0	29.7	26.6	34.0	30.7	27.4	35.0	31.6	28.2
	S.C.	23.4	21.6	20.1	25.8	23.9	22.2	28.1	26.1	24.2
	KW	3.19	3.10	3.04	3.26	3.17	3.11	3.39	3.32	3.25
115	T.C.	30.4	26.5	24.1	31.4	27.4	24.7	32.4	28.2	25.3
	S.C.	22.6	20.3	19.1	24.9	22.5	21.0	27.3	24.8	22.9
	KW	3.12	3.00	2.92	3.18	3.08	3.00	3.31	3.23	3.15
125	T.C.	27.7	23.3	21.6	28.8	24.1	21.9	29.8	24.9	22.3
	S.C.	21.8	18.9	18.1	24.1	21.2	19.8	26.5	23.4	21.5
	KW	3.05	2.90	2.80	3.10	2.99	2.89	3.23	3.14	3.05

NOTE: ALL CAPACITIES INCLUDE INDOOR FAN HEAT AT 1250 BTUH/1000 CFM.

Multipliers for determining the performance with other indoor sections.

NOTE: For dry bulb temperatures different than those listed (between 73-87 F), sensible capacity increases by 1060 BTUH per 1000 CFM per degree above the listed temperature and decreases by 1060 BTUH per 1000 CFM per degree below the listed temperature.

Air Handler	Coil	T.C.	S.C.	KW
N1AHB1206	G2FD036(S,H)17	0.98	0.98	1.01
N1VSB12	G2FD036(S,H)17	1.00	0.98	0.95
N1VSB12	G2FD046(S,H)17	1.02	1.00	0.96
F2RP/F2FP042		1.00	1.00	1.00
	G1FA048S21	1.02	1.02	1.01
	G1HD036	0.98	1.05	1.01
	G1HD048	1.06	1.11	1.05
	G1NA036S17L	1.00	0.96	0.97
	G1NA048S21D	1.00	0.96	0.98
	G1UA048S21	1.02	1.02	1.01
	G2FD036(S,H)17	0.98	0.98	1.01
	G2FD036(S,H)21	1.00	1.00	1.00
	G2FD042(S,H)21	1.01	1.01	1.02
	G1HA036H17	0.99	0.99	1.00

Variable Speed Furnace	Coil	T.C.	S.C.	KW
P1DUB16V	G2FD036(S,H)17	0.99	1.00	0.97
P1DUC20V	G1FA048S21	1.04	1.05	0.95
P1DUC20V	G2FD036(S,H)21	1.02	1.02	0.95
P1DUC20V	G2FD042(S,H)21	1.02	1.04	0.96
P1XDB12V	G2FD036(S,H)17	0.98	0.98	0.94
P1XUB12V	G2FD036(S,H)17	0.99	1.00	0.98
P1XUC16V	G1FA048S21	1.04	1.05	0.97
P1XUC16V	G2FD036(S,H)21	1.01	1.02	0.96
P1XUC16V	G2FD042(S,H)21	1.02	1.04	0.97

COOLING PERFORMANCE DATA																
AIR CONDITIONER MODEL NO.		E1RC036S(25,46)														
INDOOR COIL MODEL NO.		G1FA048S21														
CONDENSER ENTERING AIR TEMPERATURE	ID CFM	1050					1250					1450				
	ID DB (°F)	80	80	80	80	75	80	80	80	80	75	80	80	80	80	75
	ID WB (°F)	72	67	62	55	62	72	67	62	55	62	72	67	62	55	62
75	T.C.	40.0	37.2	33.6	32.2	33.6	40.7	37.7	34.4	33.7	34.4	41.4	38.2	35.2	35.2	35.2
	S.C.	18.8	24.9	29.9	32.1	25.5	19.4	26.5	32.3	33.7	27.7	20.0	28.0	34.6	35.2	29.9
	KW	2.77	2.71	2.55	2.53	2.63	2.89	2.79	2.69	2.67	2.72	3.00	2.87	2.83	2.80	2.80
85	T.C.	39.1	35.3	31.4	30.5	31.4	39.7	36.2	33.1	32.2	33.1	40.3	37.0	34.9	33.8	34.9
	S.C.	18.8	24.3	29.1	30.1	24.6	19.7	26.3	31.5	31.9	26.8	20.6	28.2	33.9	33.8	29.1
	KW	3.00	2.90	2.77	2.75	2.80	3.10	3.00	2.92	2.88	2.98	3.20	3.10	3.07	3.01	3.17
95	T.C.	38.2	33.4	29.1	28.8	29.1	38.7	34.6	31.8	30.6	31.8	39.2	35.8	34.5	32.4	34.5
	S.C.	18.7	23.7	28.2	28.0	23.6	20.0	26.1	30.7	30.2	25.9	21.2	28.4	33.2	32.4	28.2
	KW	3.23	3.08	3.00	2.98	2.97	3.31	3.21	3.15	3.10	3.25	3.39	3.33	3.31	3.22	3.53
105	T.C.	34.9	30.5	27.2	26.9	27.2	35.5	31.5	29.3	28.5	29.3	36.1	32.6	31.5	30.0	31.5
	S.C.	17.6	22.6	26.5	26.4	22.5	18.9	24.9	28.6	28.2	24.5	20.2	27.2	30.6	30.0	26.5
	KW	3.39	3.24	3.16	3.15	3.20	3.49	3.37	3.31	3.27	3.44	3.58	3.49	3.45	3.39	3.69
115	T.C.	31.6	27.5	25.2	25.1	25.2	32.3	28.4	26.9	26.4	26.9	32.9	29.3	28.5	27.7	28.5
	S.C.	16.6	21.6	24.9	24.7	21.3	17.9	23.8	26.4	26.2	23.1	19.3	26.0	27.9	27.6	24.9
	KW	3.56	3.40	3.32	3.32	3.42	3.66	3.53	3.46	3.44	3.64	3.77	3.65	3.60	3.57	3.85
125	T.C.	28.3	24.6	23.3	23.2	23.3	29.1	25.4	24.4	24.3	24.4	29.8	26.1	25.5	25.3	25.5
	S.C.	15.5	20.5	23.2	23.1	20.2	16.9	22.7	24.3	24.2	21.7	18.3	24.8	25.3	25.2	23.2
	KW	3.72	3.57	3.49	3.49	3.65	3.84	3.68	3.61	3.62	3.83	3.96	3.80	3.74	3.74	4.01

NOTE: ALL CAPACITIES INCLUDE INDOOR FAN HEAT AT 1250 BTUH/1000 CFM.

Multipliers for determining the performance with other indoor sections.

NOTE: For dry bulb temperatures different than those listed (between 73-87 F), sensible capacity increases by 1060 BTUH per 1000 CFM per degree above the listed temperature and decreases by 1060 BTUH per 1000 CFM per degree below the listed temperature.

Coil	T.C.	S.C.	KW
G1UA048S21	1.00	1.00	1.00
G1HA048H21	1.01	1.02	1.00
G2FD048S(21,24)	0.99	0.97	1.00

COOLING PERFORMANCE DATA													
AIR CONDITIONER MODEL NO.		E1RC042S06											
INDOOR COIL MODEL NO.		F2FP048											
CONDENSER ENTERING AIR TEMPERATURE	ID CFM	1200				1400				1600			
	ID DB (°F)	85	80	75	70	85	80	75	70	85	80	75	70
	ID WB (°F)	72	67	62	57	72	67	62	57	72	67	62	57
75	T.C.	47.5	43.8	40.7	36.7	48.0	44.3	41.2	37.4	48.4	44.7	41.7	37.7
	S.C.	29.2	29.4	28.4	30.1	30.7	30.9	29.9	31.9	31.9	32.1	31.2	32.9
	KW	3.24	3.19	3.18	3.13	3.33	3.29	3.28	3.23	3.47	3.42	3.41	3.36
85	T.C.	45.4	41.9	38.9	35.1	45.8	42.3	39.5	35.7	46.1	42.5	39.8	36.0
	S.C.	28.5	28.7	27.8	29.3	29.9	30.2	29.4	31.0	31.1	31.2	30.3	32.1
	KW	3.54	3.50	3.48	3.43	3.55	3.51	3.48	3.44	3.77	3.74	3.71	3.66
95	T.C.	42.4	39.1	36.4	32.8	42.8	39.5	37.0	33.3	43.0	39.9	37.2	33.7
	S.C.	27.4	27.6	26.7	28.2	29.0	29.2	28.3	29.9	29.1	29.5	28.3	31.0
	KW	3.79	3.76	3.73	3.68	3.89	3.85	3.82	3.78	4.02	3.98	3.96	3.92
105	T.C.	39.4	36.3	33.9	30.6	39.8	36.8	34.3	31.1	40.0	37.0	34.5	31.9
	S.C.	26.4	26.5	25.8	27.2	28.0	28.3	27.1	28.8	29.3	29.3	28.1	30.2
	KW	4.07	4.04	4.00	3.96	4.17	4.13	4.11	4.06	4.29	4.26	4.24	4.21
115	T.C.	36.6	33.8	31.4	28.4	36.9	34.1	31.8	29.4	37.1	34.3	32.1	29.8
	S.C.	25.5	25.6	24.6	26.2	27.2	27.2	26.2	27.9	28.2	28.2	27.3	28.2
	KW	4.38	4.35	4.33	4.27	4.47	4.44	4.42	4.38	4.61	4.58	4.55	4.51
125	T.C.	33.8	31.3	28.8	26.2	34.0	31.4	29.3	27.7	34.2	31.6	29.7	27.7
	S.C.	24.6	24.7	23.5	25.2	26.4	26.1	25.2	27.0	27.1	27.1	26.5	26.2
	KW	4.69	4.66	4.66	4.58	4.77	4.75	4.73	4.70	4.93	4.90	4.86	4.81

NOTE: ALL CAPACITIES INCLUDE INDOOR FAN HEAT AT 1250 BTUH/1000 CFM.

Multipliers for determining the performance with other indoor sections.

NOTE: For dry bulb temperatures different than those listed (between 73-87 F), sensible capacity increases by 1060 BTUH per 1000 CFM per degree above the listed temperature and decreases by 1060 BTUH per 1000 CFM per degree below the listed temperature.

Air Handler	Coil	T.C.	S.C.	KW
N1AHC1606	G2FD042(S,H)21	0.98	0.99	0.99
N1VSC16	G2FD048(S,H)21	1.01	1.00	0.98
F2RP/F2FP042		0.96	0.96	1.00
	G1FA048S21	0.99	0.99	0.98
	G1HD048	0.99	1.04	0.99
	G1NA048S21D	0.99	0.98	1.00
	G1UA048S21	0.99	0.99	0.98
	G2FD042(S,H)21	0.98	0.99	0.99
	G2FD048(S,H)21,24	0.99	1.00	0.98
	G2FD060(S,H)24	1.00	1.02	0.97
	G1HA036H17	0.96	0.97	0.97

Variable Speed Furnace	Coil	T.C.	S.C.	KW
P1DUC20V	G1FA048S21	1.00	1.01	0.95
P1DUC20V	G2FD042(S,H)21	0.99	1.01	0.96
P1DUC20V	G2FD048(S,H)21	1.00	1.02	0.96
P1XDD20V	G2FD048(S,H)24	1.01	2.37	0.95
P1XUC16V	G1FA048S21	1.00	1.01	0.95
P1XUC16V	G2FD042(S,H)21	0.99	1.01	0.97
P1XUC16V	G2FD048(S,H)21	0.99	1.00	0.98

COOLING PERFORMANCE DATA													
AIR CONDITIONER MODEL NO.		E2RC048S06, E1RC048S(25,46)*											
INDOOR COIL MODEL NO.		G1NA042S24W											
CONDENSER ENTERING AIR TEMPERATURE	ID CFM	1400				1600				1800			
	ID DB (°F)	85	80	75	70	85	80	75	70	85	80	75	70
	ID WB (°F)	72	67	62	57	72	67	62	57	72	67	62	57
75	T.C.	52.6	48.2	44.5	39.8	53.5	49.1	45.4	41.0	53.9	49.5	45.8	41.4
	S.C.	32.6	32.8	31.5	33.2	34.9	35.0	33.7	35.7	36.0	36.2	34.9	36.9
	KW	3.74	3.68	3.64	3.57	3.87	3.82	3.78	3.71	3.93	3.88	3.84	3.77
85	T.C.	50.5	46.3	42.7	38.2	51.3	47.1	43.6	39.3	51.8	47.5	44.0	39.7
	S.C.	31.9	32.0	30.8	32.3	34.1	34.2	33.0	34.9	35.4	35.5	34.3	36.0
	KW	3.92	3.85	3.79	3.70	4.06	3.99	3.93	3.84	4.12	4.05	3.99	3.91
95	T.C.	48.7	44.5	41.0	36.8	49.7	45.5	42.1	37.7	49.9	45.7	42.5	38.1
	S.C.	31.1	31.2	30.0	31.7	33.6	33.7	32.6	34.1	34.6	34.7	33.6	35.2
	KW	4.26	4.17	4.08	3.96	4.40	4.31	4.22	4.11	4.47	4.37	4.29	4.18
105	T.C.	46.7	42.7	39.3	35.3	47.6	43.6	40.3	36.1	47.9	43.9	40.5	36.5
	S.C.	30.4	30.4	29.3	30.9	32.9	32.9	31.7	33.3	33.9	33.9	32.7	34.5
	KW	4.60	4.48	4.37	4.22	4.74	4.62	4.52	4.38	4.82	4.69	4.59	4.46
115	T.C.	44.8	40.9	37.5	33.6	45.5	41.6	38.4	34.4	45.8	41.9	38.7	34.9
	S.C.	29.8	29.8	28.7	30.1	32.0	32.0	30.8	32.2	33.1	33.2	31.8	33.5
	KW	4.95	4.79	4.66	4.50	5.11	4.95	4.82	4.66	5.18	5.02	4.90	4.74
125	T.C.	42.9	39.1	35.8	32.0	43.4	39.6	36.5	32.7	43.7	39.8	36.8	33.2
	S.C.	29.2	29.2	28.1	29.3	31.1	31.1	29.8	31.1	32.3	32.5	31.0	32.5
	KW	5.30	5.10	4.95	4.78	5.48	-0.72	5.12	4.94	5.54	5.35	5.21	5.02

NOTE: ALL CAPACITIES INCLUDE INDOOR FAN HEAT AT 1250 BTUH/1000 CFM.

Multipliers for determining the performance with other indoor sections.

NOTE: For dry bulb temperatures different than those listed (between 73-87 F), sensible capacity increases by 1060 BTUH per 1000 CFM per degree above the listed temperature and decreases by 1060 BTUH per 1000 CFM per degree below the listed temperature.

Air Handler	Coil	T.C.	S.C.	KW
N1AHC1606	G2FD048(S,H)21	0.99	1.02	0.99
N1AHD2006	G2FD060(S,H)24	1.01	1.05	1.00
N1AHD2006	G2FD061H24	1.02	1.11	1.00
N1VSD20	G2FD060(S,H)24	1.02	1.05	0.96
N1VSD20	G2FD061H24	1.03	1.11	0.96
F2FP045		1.00	1.02	0.98
F2FP048		0.99	1.03	1.01
F2FV060		1.02	1.09	0.96
	G1FA048S21*	0.99	1.01	1.09
	G1FA060S21,24	1.01	1.05	1.00
	G1HD060	1.00	1.04	1.00
	G1UA048S21*	0.99	1.01	0.98
	G1UA060S21,24	1.01	1.05	1.00
	G2FD048(S,H)21,24*	0.99	1.02	0.99
	G2FD060(S,H)24	1.01	1.05	1.00
	G2FD061H24	1.02	1.11	1.00
	G1HA048H21	0.97	0.99	1.07

* Matchups marked with asterisks are the only ones that may be matched with 3-Phase outdoor units.

Variable Speed Furnace	Coil	T.C.	S.C.	KW
P1DUC20V	G1FA048S21	1.00	1.02	0.96
P1DUC20V	G1FA060S21	1.01	1.05	0.97
P1DUC20V	G2FD048(S,H)21	0.99	1.02	0.98
P1XDD20V	G2FD048(S,H)24	1.02	1.06	1.00
P1XUC16V	G1FA048S21	0.99	1.01	0.98
P1XUC16V	G1FA060S21	1.00	1.03	0.98
P1XUC16V	G2FD048(S,H)21	0.98	1.00	0.99
P1XUD20V	G1FA060S24	1.01	1.05	0.98
P1XUD20V	G2FD060(S,H)24	1.01	1.05	0.98

COOLING PERFORMANCE DATA										
AIR CONDITIONER MODEL NO.		E2RC060S06								
INDOOR COIL MODEL NO.		G2FD060(S,H)24								
CONDENSER ENTERING AIR TEMPERATURE	ID CFM	1500			1700			1900		
	ID DB (°F)	85	80	70	85	80	70	85	80	70
	ID WB (°F)	72	67	57	72	67	57	72	67	57
75	T.C.	63.5	60.9	57.7	63.8	61.5	58.3	64.0	62.1	59.0
	S.C.	40.1	39.7	38.2	42.1	41.7	40.5	44.1	43.7	42.8
	KW	4.31	4.31	4.31	4.38	4.38	4.38	4.46	4.46	4.45
85	T.C.	62.2	58.7	54.5	62.8	59.5	55.4	63.4	60.3	56.2
	S.C.	39.9	38.7	36.8	42.3	41.0	39.2	44.6	43.3	41.7
	KW	4.81	4.79	4.77	4.88	4.87	4.84	4.96	4.94	4.91
95	T.C.	61.0	56.4	51.4	61.9	57.5	52.4	62.8	58.6	53.4
	S.C.	39.7	37.8	35.3	42.4	40.4	38.0	45.2	42.9	40.6
	KW	5.31	5.27	5.23	5.38	5.35	5.30	5.46	5.43	5.38
105	T.C.	57.5	52.4	47.6	58.5	53.6	48.6	59.4	54.7	49.6
	S.C.	38.5	36.2	34.0	41.3	38.8	36.5	44.1	41.3	39.0
	KW	5.90	5.85	5.79	5.98	5.93	5.87	6.06	6.01	5.95
115	T.C.	54.1	48.5	43.8	55.1	49.6	44.8	56.1	50.8	45.8
	S.C.	37.4	34.6	32.7	40.2	37.2	35.1	43.1	39.8	37.5
	KW	6.49	6.42	6.35	6.58	6.51	6.43	6.66	6.59	6.52
125	T.C.	50.7	44.5	40.0	51.7	45.7	41.0	52.7	46.9	42.0
	S.C.	36.3	33.0	31.4	39.1	35.6	33.7	42.0	38.2	36.0
	KW	7.08	6.99	6.91	7.18	7.09	6.99	7.26	7.17	7.09

NOTE: ALL CAPACITIES INCLUDE INDOOR FAN HEAT AT 1250 BTUH/1000 CFM.

Multipliers for determining the performance with other indoor sections.

NOTE: For dry bulb temperatures different than those listed (between 73-87 F), sensible capacity increases by 1060 BTUH per 1000 CFM per degree above the listed temperature and decreases by 1060 BTUH per 1000 CFM per degree below the listed temperature.

Air Handler	Coil	T.C.	S.C.	KW
N1AHD2006	G2FD060(S,H)24	1.00	1.00	1.00
N1AHD2006	G2FD061H24	1.03	1.09	1.02
N1VSD20	G2FD060(S,H)24	1.03	1.00	0.93
N1VSD20	G2FD061H24	1.03	1.09	1.01
F2FP060		0.99	0.99	1.02
F2FV060		1.00	1.07	1.01
	G1FA060S21,24	1.00	1.00	1.00
	G1HD060	1.01	1.01	1.00
	G1NA060S24T	0.98	0.98	1.00
	G1UA060S21,24	1.00	1.00	1.00
	G2FD061H24	1.03	1.09	1.02
	G1HA060H24	0.98	0.98	0.98

Variable Speed Furnace	Coil	T.C.	S.C.	KW
P1DUC20V	G1FA060S21	1.00	1.00	1.00
P1XDD20V	G2FD060(S,H)24	1.00	1.00	1.03
P1XUC20V	G1FA060S21	0.99	0.99	1.00
P1XUD20V	G1FA060S24	0.99	0.99	1.00
P1XUD20V	G2FD060(S,H)24	0.99	0.99	1.00
P1XUD20V	G2FD061H24	1.02	1.08	1.04

COOLING PERFORMANCE DATA																
AIR CONDITIONER MODEL NO.		E1RC060S25,46														
INDOOR COIL MODEL NO.		G1FA060S21,24														
CONDENSER ENTERING AIR TEMPERATURE	ID CFM	1500					1700					1900				
	ID DB (°F)	80	80	80	80	75	80	80	80	80	75	80	80	80	80	75
	ID WB (°F)	72	67	62	55	62	72	67	62	55	62	72	67	62	55	62
75	T.C.	62.6	59.3	53.6	53.7	53.6	62.8	59.7	56.4	54.9	56.4	62.9	60.0	59.2	56.1	59.2
	S.C.	29.2	38.2	45.7	38.9	48.8	30.3	40.2	47.4	41.2	50.5	31.3	42.2	49.0	43.5	52.2
	KW	4.15	4.10	4.03	4.03	4.46	4.23	4.17	4.16	4.12	4.62	4.30	4.24	4.29	4.20	4.78
85	T.C.	61.4	56.5	51.2	51.2	51.2	61.8	57.1	52.9	52.2	52.9	62.3	57.7	54.6	53.1	54.6
	S.C.	28.9	37.2	44.6	37.8	47.3	30.1	39.3	46.7	40.0	48.9	31.3	41.4	48.7	42.2	50.5
	KW	4.63	4.55	4.47	4.47	4.84	4.71	4.62	4.57	4.57	4.92	4.79	4.70	4.68	4.66	5.01
95	T.C.	60.1	53.7	48.7	48.7	48.7	60.9	54.6	49.4	49.4	49.4	61.6	55.4	50.0	50.1	50.0
	S.C.	28.5	36.2	43.5	36.6	45.8	29.9	38.4	46.0	38.8	47.3	31.3	40.5	48.4	41.0	48.7
	KW	5.10	5.00	4.92	4.91	5.21	5.19	5.08	4.99	5.02	5.23	5.27	5.16	5.06	5.12	5.24
105	T.C.	56.9	50.8	45.8	45.6	45.8	57.6	51.8	46.5	46.3	46.5	58.3	52.7	47.2	47.0	47.2
	S.C.	27.5	35.0	41.9	35.2	43.5	28.9	37.1	44.0	37.4	44.9	30.2	39.2	46.1	39.6	46.3
	KW	5.69	5.56	5.43	5.45	5.70	5.77	5.66	5.51	5.56	5.71	5.85	5.76	5.59	5.66	5.73
115	T.C.	53.7	47.8	42.9	42.5	42.9	54.4	49.0	43.6	43.2	43.6	55.0	50.1	44.3	43.9	44.3
	S.C.	26.6	33.9	40.3	33.9	41.3	27.8	35.9	42.1	36.1	42.6	29.1	38.0	43.8	38.3	43.9
	KW	6.29	6.12	5.95	5.99	6.19	6.36	6.24	6.03	6.09	6.20	6.43	6.35	6.12	6.19	6.21
125	T.C.	50.5	44.9	40.0	39.4	40.0	51.1	46.2	40.8	40.1	40.8	51.7	47.4	41.5	40.8	41.5
	S.C.	25.6	32.7	38.7	32.5	39.0	26.8	34.7	40.1	34.7	40.3	28.0	36.7	41.5	36.9	41.5
	KW	6.88	6.68	6.46	6.53	6.68	6.95	6.82	6.56	6.63	6.69	7.01	6.95	6.65	6.73	6.69

NOTE: ALL CAPACITIES INCLUDE INDOOR FAN HEAT AT 1250 BTUH/1000 CFM.

Multipliers for determining the performance with other indoor sections.

NOTE: For dry bulb temperatures different than those listed (between 73-87 F), sensible capacity increases by 1060 BTUH per 1000 CFM per degree above the listed temperature and decreases by 1060 BTUH per 1000 CFM per degree below the listed temperature.

Coil	T.C.	S.C.	KW
G1UA048S21	1.00	1.00	1.00
G1HA048H21	1.01	1.02	1.00
G2FD048S(21,24)	0.99	0.97	1.00

HEATING PERFORMANCE DATA										
CONDENSING UNIT MODEL NO.		E1RC018S06								
EVAPORATOR COIL MODEL NO.		F2RP/F2FP024								
AIR TEMP. ENTERING OUTDOOR UNIT	AIR TEMP. ENTERING INDOOR COIL	ID CFM								
		500			650			800		
		MBTUH	KW	C.O.P.	MBTUH	KW	C.O.P.	MBTUH	KW	C.O.P.
60	60	24.9	1.78	4.11	25.1	1.76	4.18	25.3	1.75	4.25
	70	22.2	1.83	3.57	22.9	1.83	3.68	23.6	1.82	3.80
	80	19.7	1.90	3.05	20.9	1.91	3.20	22.0	1.93	3.35
47	60	20.2	1.67	3.55	20.8	1.69	3.61	21.4	1.71	3.67
	70	18.0	1.72	3.08	19.0	1.74	3.20	19.9	1.76	3.32
	80	15.9	1.78	2.62	17.2	1.80	2.80	18.5	1.82	2.97
40	60	17.3	1.47	3.46	17.8	1.48	3.54	18.2	1.48	3.62
	70	15.6	1.55	2.94	16.1	1.57	3.01	16.6	1.58	3.08
	80	13.7	1.67	2.41	14.3	1.70	2.47	14.9	1.72	2.53
30	60	14.9	1.36	3.23	15.5	1.33	3.44	16.2	1.30	3.66
	70	13.1	1.46	2.64	13.9	1.45	2.80	14.6	1.45	2.97
	80	11.1	1.62	2.01	12.0	1.66	2.13	12.9	1.69	2.23
17	60	11.2	1.46	2.26	11.6	1.50	2.27	12.0	1.55	2.28
	70	9.8	1.46	1.98	10.6	1.50	2.06	11.3	1.55	2.13
	80	8.5	1.47	1.70	9.5	1.51	1.85	10.6	1.56	1.99
10	60	9.1	1.41	1.90	9.6	1.45	1.95	10.2	1.49	1.99
	70	8.1	1.39	1.71	8.7	1.43	1.79	9.4	1.48	1.86
	80	7.1	1.38	1.51	7.9	1.42	1.63	8.7	1.47	1.73

NOTE: ALL CAPACITIES INCLUDE INDOOR FAN HEAT AT 1250 BTUH/1000 CFM.

Multipliers for determining the performance with other indoor sections.

Air Handler	Coil	MBH	KW	COP
N1AHB0806	G2FD024(S,H)17	0.99	1.06	0.93
N1VSB12	G2FD024(S,H)17	0.99	1.09	0.90
	G1FA024S14,17	0.99	0.98	1.01
	G1FA030S14	1.00	1.01	0.99
	G1HD024	1.00	1.01	0.99
	G1NA030S17K	0.95	1.02	0.93
	G1UA024S14,17	0.99	0.98	1.01
	G1UA030S14	1.00	1.01	0.99
	G2FD024(S,H)14,17	0.99	1.06	0.93
	G1HA024H14	0.97	1.04	0.92

Variable Speed Furnace	Coil	T.C.	S.C.	KW
P1DUA12V	G1FA024S14	0.97	1.04	0.93
P1DUA12V	G1FA030S14	0.98	1.06	0.92
P1DUA12V	G2FD024(S,H)14	0.97	1.13	0.85
P1XDB12V	G2FD024(S,H)17	0.96	1.06	0.91
P1XUB12V	G1FA024S17	0.97	1.04	0.93
P1XUB12V	G2FD024(S,H)17	0.97	1.13	0.85

HEATING PERFORMANCE DATA										
CONDENSING UNIT MODEL NO		E1RC024S06								
EVAPORATOR COIL MODEL NO		F2RP/F2FP030								
AIR TEMP. ENTERING OUTDOOR UNIT	AIR TEMP. ENTERING INDOOR COIL	ID CFM								
		700			850			1000		
		MBTUH	KW	C.O.P.	MBTUH	KW	C.O.P.	MBTUH	KW	C.O.P.
60	60	28.7	2.22	3.79	29.1	2.22	3.83	29.4	2.25	3.85
	70	26.8	2.26	3.48	27.5	2.27	3.56	27.9	2.29	3.58
	80	24.9	2.29	3.19	26.0	2.30	3.32	26.4	2.32	3.33
47	60	24.3	2.14	3.34	25.1	2.17	3.39	25.4	2.19	3.40
	70	22.4	2.19	3.00	23.6	2.22	3.12	24.1	2.24	3.15
	80	20.4	2.23	2.68	22.1	2.26	2.87	22.8	2.29	2.92
40	60	21.5	2.08	3.04	22.3	2.09	3.13	22.6	2.13	3.11
	70	20.0	2.13	2.75	20.9	2.15	2.86	21.3	2.18	2.87
	80	18.4	2.18	2.48	19.5	2.19	2.61	20.0	2.23	2.64
30	60	18.3	1.97	2.72	19.2	1.99	2.83	19.7	2.01	2.87
	70	17.1	2.02	2.48	17.9	2.05	2.56	18.4	2.08	2.59
	80	15.8	2.06	2.25	16.6	2.10	2.31	17.0	2.14	2.33
17	60	15.9	1.91	2.44	15.6	1.95	2.35	15.8	1.99	2.33
	70	13.8	1.96	2.07	14.0	1.99	2.06	14.4	2.04	2.07
	80	11.7	2.01	1.71	12.5	2.04	1.79	13.0	2.09	1.82
10	60	12.5	1.81	2.02	13.3	1.86	2.09	13.6	1.90	2.10
	70	10.5	1.85	1.67	11.7	1.90	1.81	12.3	1.94	1.86
	80	8.5	1.89	1.31	10.2	1.94	1.54	11.0	1.99	1.62

NOTE: ALL CAPACITIES INCLUDE INDOOR FAN HEAT AT 1250 BTUH/1000 CFM.

Multipliers for determining the performance with other indoor sections.

Air Handler	Coil	MBH	KW	COP
N1AHB0806	G2FD024(S,H)17	0.98	0.97	1.01
N1AHB0806	G2FD030(S,H)17	0.98	0.99	0.99
N1VSB12	G2FD030(S,H)17	0.98	1.02	0.96
	G1FA030S14	0.98	0.97	1.01
	G1FA036S17,21	0.98	0.99	0.99
	G1HD024	0.98	0.98	0.99
	G1HD036	0.98	1.03	0.95
	G1NA030S17K	1.00	1.01	0.99
	G1NA030S21M	1.00	1.01	0.99
	G1UA030S14	0.98	0.97	1.01
	G1UA036S17,21	0.98	0.99	0.99
	G2FD024(S,H)14,17	0.98	0.97	1.01
	G2FD030(S,H)17	0.98	0.99	0.99
	G2FD030(S,H)17	0.98	0.99	0.99
	G2FD035(S,H)14	0.98	0.99	0.99
	G1HA024H14	0.96	0.95	1.00

Variable Speed Furnace	Coil	T.C.	S.C.	KW
P1DUA12V	G1FA030S14	0.96	1.01	0.95
P1DUA12V	G2FD024(S,H)14	0.96	1.01	0.95
P1DUB16V	G1FA036S17	0.96	1.04	0.93
P1DUB16V	G2FD024(S,H)17	0.96	1.01	0.95
P1DUB16V	G2FD030(S,H)17	0.97	1.04	0.93
P1XDB12V	G2FD024(S,H)17	0.95	1.02	0.94
P1XDB12V	G2FD030(S,H)17	0.96	1.04	0.92
P1XUB12V	G1FA036S17	0.96	1.04	0.92
P1XUB12V	G2FD024(S,H)17	0.95	1.02	0.94
P1XUB12V	G2FD030(S,H)17	0.96	1.04	0.92

HEATING PERFORMANCE DATA										
CONDENSING UNIT MODEL NO		E1RC030S06								
EVAPORATOR COIL MODEL NO		F2RP/F2FP036								
AIR TEMP. ENTERING OUTDOOR UNIT	AIR TEMP. ENTERING INDOOR COIL	ID CFM								
		800			1000			1200		
		MBTUH	KW	C.O.P.	MBTUH	KW	C.O.P.	MBTUH	KW	C.O.P.
60	60	34.6	2.55	3.98	35.1	2.48	4.16	34.1	2.25	4.45
	70	33.5	2.69	3.65	34.5	2.62	3.86	34.1	2.39	4.19
	80	32.3	2.79	3.40	33.9	2.73	3.64	34.1	2.49	4.02
47	60	31.4	2.47	3.74	30.4	2.44	3.66	30.3	2.25	3.95
	70	29.3	2.58	3.33	29.0	2.58	3.30	29.7	2.38	3.67
	80	27.3	2.67	2.99	28.7	2.68	3.14	29.2	2.49	3.44
40	60	26.4	2.41	3.20	27.4	2.42	3.32	27.6	2.24	3.62
	70	24.8	2.53	2.88	26.3	2.54	3.05	27.0	2.36	3.36
	80	23.2	2.63	2.60	25.3	2.64	2.81	26.4	2.46	3.14
30	60	23.1	2.34	2.91	24.2	2.36	3.00	24.9	2.22	3.29
	70	21.7	2.44	2.61	23.0	2.46	2.74	23.9	2.30	3.04
	80	20.2	2.53	2.34	21.8	2.56	2.50	22.8	2.39	2.80
17	60	18.9	2.22	2.50	19.4	2.27	2.50	19.9	2.13	2.74
	70	17.3	2.28	2.23	18.0	2.38	2.20	18.6	2.20	2.49
	80	15.7	2.36	1.95	16.5	2.41	2.00	17.4	2.28	2.24
10	60	16.0	2.14	2.20	16.7	2.19	2.24	17.5	2.07	2.47
	70	14.1	2.18	1.90	15.2	2.23	2.00	16.0	2.11	2.23
	80	12.2	2.23	1.60	13.6	2.29	1.74	14.5	2.16	1.97

NOTE: ALL CAPACITIES INCLUDE INDOOR FAN HEAT AT 1250 BTUH/1000 CFM.

Multipliers for determining the performance with other indoor sections.

Air Handler	Coil	MBH	KW	COP
N1AHB1206	G2FD036(S,H)17	1.01	1.00	1.01
F2RP/F2FP030		0.98	0.97	1.01
N1VSB12	G2FD036(S,H)17	1.00	1.03	0.97
	G1FA036S14	1.01	1.01	1.00
	G1FA036S17,21	1.00	0.99	1.01
	G1HD036	1.01	1.03	0.98
	G1HD048	1.03	1.04	0.99
	G1NA036S17L	1.00	1.00	1.00
	G1NA048S21D	1.00	1.00	1.00
	G1UA036S14	1.01	1.01	1.00
	G1UA036S17,21	1.00	0.99	1.01
	G2FD030(S,H)17	1.00	0.99	1.01
	G2FD030(S,H)17	1.00	0.99	1.01
	G2FD035(S,H)14	1.00	0.99	1.01
	G2FD036(S,H)17	1.01	1.00	1.01
	G2FD036(S,H)21	1.00	0.99	1.01
	G1HA036H14	0.99	0.98	1.00

Variable Speed Furnace	Coil	T.C.	S.C.	KW
P1DUA12V	G1FA036S14	1.00	1.04	0.96
P1DUA12V	G2FD035(S,H)14	0.98	1.03	0.95
P1DUB16V	G1FA036S17	0.98	1.04	0.94
P1DUB16V	G2FD036(S,H)17	0.99	1.05	0.94
P1XUB12V	G1FA036S17	0.99	1.05	0.96
P1XUB12V	G2FD030(S,H)17	0.99	1.05	0.96
P1XUB12V	G2FD036(S,H)17	0.99	1.06	0.94
P1XDB12V	G2FD036(S,H)17	0.98	1.04	0.96

HEATING PERFORMANCE DATA										
CONDENSING UNIT MODEL NO		E1RC036S06								
EVAPORATOR COIL MODEL NO		F2RP/F2FP036								
AIR TEMP. ENTERING OUTDOOR UNIT	AIR TEMP. ENTERING INDOOR COIL	ID CFM								
		1000			1200			1400		
		MBTUH	KW	C.O.P.	MBTUH	KW	C.O.P.	MBTUH	KW	C.O.P.
60	60	42.0	2.86	4.30	42.1	2.85	4.33	42.2	2.84	4.35
	70	40.0	2.98	3.94	40.9	2.99	4.02	41.8	2.99	4.10
	80	38.0	3.13	3.56	39.7	3.15	3.69	41.4	3.17	3.83
47	60	36.2	2.80	3.79	36.4	2.80	3.81	36.6	2.81	3.83
	70	34.2	2.92	3.44	35.0	2.93	3.50	35.7	2.95	3.56
	80	32.1	3.06	3.08	33.5	3.09	3.18	34.9	3.12	3.28
40	60	32.3	2.73	3.47	32.7	2.75	3.49	33.1	2.77	3.51
	70	30.5	2.83	3.17	31.2	2.85	3.21	31.8	2.88	3.25
	80	28.4	2.95	2.83	29.4	2.98	2.89	30.3	3.01	2.95
30	60	27.7	2.60	3.13	28.4	2.63	3.17	29.1	2.65	3.22
	70	26.0	2.65	2.88	26.8	2.69	2.92	27.6	2.73	2.97
	80	23.8	2.73	2.55	24.7	2.78	2.60	25.6	2.84	2.65
17	60	22.3	2.49	2.62	22.8	2.54	2.63	23.2	2.58	2.64
	70	20.0	2.57	2.29	20.6	2.62	2.30	21.1	2.67	2.32
	80	17.9	2.65	1.98	18.5	2.70	2.01	19.1	2.76	2.03
10	60	18.8	2.36	2.34	19.4	2.42	2.36	20.0	2.47	2.38
	70	16.2	2.42	1.97	17.1	2.47	2.03	17.6	2.53	2.04
	80	13.8	2.46	1.64	14.8	2.51	1.73	15.3	2.58	1.74

NOTE: ALL CAPACITIES INCLUDE INDOOR FAN HEAT AT 1250 BTUH/1000 CFM.

Multipliers for determining the performance with other indoor sections.

Air Handler	Coil	MBH	KW	COP
N1AHB1206	G2FD036(S,H)17	1.01	1.01	1.00
F2RP/F2FP042		1.00	1.00	1.00
N1VSB12	G2FD036(S,H)17	1.01	1.03	0.98
N1VSB12	G2FD046(S,H)17	1.01	1.03	0.98
	G1FA048S21	1.02	1.02	1.00
	G1HD036	1.01	1.02	0.99
	G1HD048	1.01	1.02	0.99
	G1NA036S17L	1.03	0.94	1.09
	G1NA048S21D	1.03	1.00	1.03
	G1UA048S21	1.02	1.02	1.00
	G2FD036(S,H)17	1.01	1.01	1.00
	G2FD036(S,H)21	1.00	0.99	1.01
	G2FD042(S,H)21	1.01	1.01	1.01
	G1HA036H17	0.99	0.99	1.00

Variable Speed Furnace	Coil	T.C.	S.C.	KW
P1DUB16V	G2FD036(S,H)17	1.00	1.05	0.95
P1DUC20V	G1FA048S21	1.00	1.08	0.93
P1DUC20V	G2FD036(S,H)21	0.98	1.03	0.95
P1DUC20V	G2FD042(S,H)21	0.98	1.04	0.94
P1XDB12V	G2FD036(S,H)17	1.00	1.00	1.00
P1XUB12V	G2FD036(S,H)17	1.00	1.04	0.96
P1XUC16V	G1FA048S21	1.01	1.07	0.94
P1XUC16V	G2FD036(S,H)21	0.99	1.03	0.96
P1XUC16V	G2FD042(S,H)21	0.98	1.03	0.96

HEATING PERFORMANCE DATA										
CONDENSING UNIT MODEL NO		E1RC036S25/46								
EVAPORATOR COIL MODEL NO		G1FA048S21								
AIR TEMP. ENTERING OUTDOOR UNIT	AIR TEMP. ENTERING INDOOR COIL	ID CFM								
		1050			1250			1450		
		MBTUH	KW	C.O.P.	MBTUH	KW	C.O.P.	MBTUH	KW	C.O.P.
60	60	39.7	3.08	3.78	38.3	3.02	3.72	36.8	2.96	3.65
	70	39.5	3.24	3.59	38.5	3.19	3.54	37.5	3.15	3.50
	80	39.2	3.39	3.39	38.7	3.37	3.37	38.1	3.35	3.34
47	60	35.1	2.81	3.66	34.1	2.78	3.59	33.0	2.76	3.51
	70	34.2	2.93	3.42	34.0	2.95	3.38	33.1	2.91	3.34
	80	32.9	3.03	3.18	33.0	3.05	3.18	33.1	3.06	3.17
40	60	31.3	2.66	3.45	31.0	2.67	3.41	30.7	2.67	3.37
	70	30.3	2.76	3.23	30.5	2.78	3.22	30.7	2.81	3.21
	80	29.3	2.85	3.01	30.0	2.90	3.03	30.7	2.95	3.05
30	60	28.1	2.57	3.21	28.1	2.59	3.18	28.0	2.61	3.15
	70	26.2	2.55	3.02	26.5	2.58	3.01	26.9	2.62	3.01
	80	24.3	2.53	2.82	25.0	2.58	2.85	25.7	2.63	2.87
17	60	21.0	2.36	2.61	21.6	2.41	2.63	22.1	2.45	2.64
	70	19.5	2.25	2.54	20.2	2.37	2.50	20.6	2.54	2.39
	80	18.0	2.55	2.07	18.6	2.59	2.10	19.1	2.63	2.13
10	60	17.2	2.25	2.29	18.1	2.31	2.33	18.9	2.37	2.37
	70	15.9	2.41	1.98	16.6	2.45	2.01	17.2	2.50	2.05
	80	14.6	2.56	1.67	15.1	2.60	1.70	15.5	2.63	1.73

NOTE: ALL CAPACITIES INCLUDE INDOOR FAN HEAT AT 1250 BTUH/1000 CFM.

Multipliers for determining the performance with other indoor sections.

Coil	MBH	KW	COP
G1UA048S21	1.00	1.00	1.00
G1HA048H21	0.99	0.99	0.99
G2FD048S(21,24)	1.01	1.00	1.01

HEATING PERFORMANCE DATA										
CONDENSING UNIT MODEL NO		E1RC042S06								
EVAPORATOR COIL MODEL NO		F2FP048								
AIR TEMP. ENTERING OUTDOOR UNIT	AIR TEMP. ENTERING INDOOR COIL	ID CFM								
		1200			1400			1600		
		MBTUH	KW	C.O.P.	MBTUH	KW	C.O.P.	MBTUH	KW	C.O.P.
60	60	49.7	3.33	4.38	48.5	3.26	4.36	47.2	3.19	4.33
	70	50.9	3.57	4.18	50.0	3.49	4.20	49.1	3.42	4.21
	80	50.8	3.89	3.83	50.2	3.80	3.87	49.7	3.72	3.92
47	60	41.9	3.23	3.81	41.4	3.20	3.80	40.8	3.16	3.79
	70	42.3	3.46	3.58	41.5	3.60	3.38	41.6	3.38	3.61
	80	41.9	3.77	3.26	41.8	3.72	3.29	41.6	3.67	3.33
40	60	37.0	3.19	3.40	36.6	3.16	3.39	36.2	3.14	3.39
	70	36.8	3.42	3.15	36.6	3.39	3.16	36.4	3.36	3.17
	80	36.0	3.71	2.84	35.9	3.67	2.87	35.9	3.63	2.90
30	60	33.9	3.08	3.22	33.9	3.07	3.23	33.9	3.07	3.24
	70	33.2	3.31	2.94	33.2	3.29	2.96	33.1	3.27	2.97
	80	32.2	3.59	2.63	32.1	3.55	2.65	32.0	3.51	2.67
17	60	26.3	2.94	2.62	26.6	2.95	2.64	26.9	2.97	2.66
	70	25.1	3.13	2.35	25.2	3.21	2.30	25.8	3.15	2.40
	80	23.8	3.36	2.08	24.3	3.37	2.11	24.7	3.37	2.15
10	60	23.2	2.84	2.39	23.5	2.87	2.40	23.8	2.90	2.41
	70	21.5	3.00	2.10	22.0	3.03	2.12	22.4	3.06	2.14
	80	20.1	3.20	1.84	20.6	3.23	1.87	21.1	3.26	1.90

NOTE: ALL CAPACITIES INCLUDE INDOOR FAN HEAT AT 1250 BTUH/1000 CFM.

Multipliers for determining the performance with other indoor sections.

Air Handler	Coil	MBH	KW	COP
N1AHC1606	G2FD042(S,H)21	0.99	0.95	1.04
F2RP/F2FP042		0.99	0.94	1.05
N1VSC16	G2FD048(S,H)21	1.00	1.00	1.00
	G1FA048S21	1.00	0.97	1.03
	G1HD048	1.00	0.98	1.02
	G1NA048S21D	0.98	0.92	1.06
	G1UA048S21	1.00	0.97	1.03
	G2FD042(S,H)21	0.99	0.95	1.04
	G2FD048(S,H)21,24	1.00	0.97	1.03
	G2FD060(S,H)24	1.00	0.99	1.01
	G1HA036H17	0.97	0.93	1.03

Variable Speed Furnace	Coil	T.C.	S.C.	KW
P1DUC20V	G1FA048S21	0.99	1.00	0.99
P1DUC20V	G2FD042(S,H)21	0.98	0.98	1.00
P1DUC20V	G2FD048(S,H)21	0.99	0.99	1.00
P1XDD20V	G2FD048(S,H)24	0.96	0.97	1.00
P1XUC16V	G1FA048S21	0.99	1.00	0.99
P1XUC16V	G2FD042(S,H)21	0.98	0.97	1.01
P1XUC16V	G2FD048(S,H)21	1.00	0.98	1.02

HEATING PERFORMANCE DATA										
CONDENSING UNIT MODEL NO		E2RC048S06, E1RC048S(25,46)*								
EVAPORATOR COIL MODEL NO		G1NA042S24W								
AIR TEMP. ENTERING OUTDOOR UNIT	AIR TEMP. ENTERING INDOOR COIL	ID CFM								
		1400			1600			1800		
		MBTUH	KW	C.O.P.	MBTUH	KW	C.O.P.	MBTUH	KW	C.O.P.
60	60	53.1	4.58	3.40	53.3	4.54	3.44	53.6	4.50	3.49
	70	52.8	4.51	3.43	53.2	4.46	3.50	53.6	4.42	3.56
	80	52.4	4.40	3.49	53.0	4.35	3.58	53.7	4.30	3.66
47	60	48.1	4.90	2.88	48.0	4.37	3.23	48.0	3.94	3.57
	70	47.3	4.64	2.99	47.5	4.39	3.18	47.7	4.16	3.36
	80	46.5	4.37	3.12	47.0	4.37	3.15	47.5	4.37	3.19
40	60	48.1	4.42	3.19	46.4	4.35	3.13	44.7	4.28	3.06
	70	46.9	4.49	3.06	45.6	4.43	3.02	44.3	4.38	2.97
	80	45.7	4.52	2.97	44.8	4.47	2.94	44.0	4.43	2.91
30	60	38.6	3.88	2.92	39.1	3.91	2.93	39.6	3.95	2.94
	70	37.6	4.04	2.73	38.0	4.07	2.74	38.4	4.10	2.75
	80	36.5	4.17	2.57	36.9	4.20	2.58	37.3	4.22	2.59
17	60	31.2	3.39	2.70	31.6	3.43	2.71	32.0	3.46	2.71
	70	29.7	3.63	2.40	30.0	3.66	2.41	30.3	3.69	2.41
	80	28.2	3.87	2.14	28.4	3.90	2.14	28.7	3.92	2.14
10	60	26.3	3.02	2.56	26.9	3.06	2.58	27.5	3.10	2.60
	70	24.6	3.28	2.20	25.1	3.31	2.22	25.5	3.34	2.24
	80	22.8	3.56	1.88	23.2	3.58	1.90	23.5	3.61	1.91

NOTE: ALL CAPACITIES INCLUDE INDOOR FAN HEAT AT 1250 BTUH/1000 CFM.

Multipliers for determining the performance with other indoor sections.

Air Handler	Coil	MBH	KW	COP
N1AHC1606	G2FD048(S,H)21	0.98	0.96	1.02
N1AHD2006	G2FD060(S,H)24	0.98	0.94	1.04
N1AHD2006	G2FD061H24	0.96	0.92	1.04
F2FP045		0.97	0.96	1.01
F2FP048		0.98	0.95	1.03
F2FV060		0.97	0.96	1.00
N1VSD20	G2FD060(S,H)24	0.97	0.96	1.00
N1VSD20	G2FD061H24	0.95	0.95	1.00
	G1FA048S21*	0.98	0.96	1.02
	G1FA060S21,24	0.98	0.94	1.04
	G1HD060	0.96	0.96	0.99
	G1UA048S21*	0.98	0.96	1.02
	G1UA060S21,24	0.98	0.94	1.04
	G2FD048(S,H)21,24*	0.98	0.96	1.02
	G2FD060(S,H)24	0.98	0.94	1.04
	G2FD061H24	0.96	0.92	1.04
	G1HA048H21	0.96	0.94	1.01

* Matchups marked with asterisks are the only ones that may be matched with 3-Phase outdoor units.

Variable Speed Furnace	Coil	T.C.	S.C.	KW
P1DUC20V	G1FA048S21	0.97	0.98	0.99
P1DUC20V	G1FA060S21	0.97	0.95	1.02
P1DUC20V	G2FD048(S,H)21	0.98	0.97	1.01
P1XDD20V	G2FD048(S,H)24	0.98	2.37	0.41
P1XUC16V	G1FA048S21	0.98	0.97	1.01
P1XUC16V	G1FA060S21	0.97	0.95	1.03
P1XUC16V	G2FD048(S,H)21	0.97	0.96	1.01
P1XUD20V	G1FA060S24	0.98	0.95	1.02
P1XUD20V	G2FD060(S,H)24	0.98	0.95	1.02

HEATING PERFORMANCE DATA										
CONDENSING UNIT MODEL NO		E2RC060S06								
EVAPORATOR COIL MODEL NO		G2FD060(S,H)24								
AIR TEMP. ENTERING OUTDOOR UNIT	AIR TEMP. ENTERING INDOOR COIL	ID CFM								
		1500			1700			1900		
		MBTUH	KW	C.O.P.	MBTUH	KW	C.O.P.	MBTUH	KW	C.O.P.
60	60	73.4	5.12	4.20	74.1	5.03	4.32	74.8	4.94	4.44
	70	71.6	5.52	3.81	72.9	5.42	3.94	74.1	5.33	4.08
	80	69.7	6.00	3.41	71.6	5.90	3.56	73.4	5.81	3.71
47	60	59.9	4.60	3.82	61.2	4.58	3.92	62.6	4.56	4.02
	70	57.3	4.93	3.41	58.5	4.90	3.50	59.6	4.87	3.59
	80	54.7	5.35	3.00	55.7	5.31	3.07	56.7	5.27	3.15
40	60	50.9	4.35	3.43	51.5	4.34	3.47	52.0	4.33	3.52
	70	47.7	4.63	3.02	47.9	4.59	3.06	48.0	4.56	3.09
	80	44.6	4.99	2.62	44.3	4.92	2.64	43.9	4.86	2.65
30	60	43.4	4.15	3.07	44.3	4.13	3.14	45.2	4.12	3.22
	70	42.2	4.49	2.76	42.3	4.45	2.79	42.3	4.41	2.81
	80	40.9	4.91	2.45	40.2	4.85	2.43	39.5	4.80	2.41
17	60	34.8	3.92	2.61	35.5	3.92	2.66	36.2	3.92	2.71
	70	34.2	4.26	2.36	34.8	4.25	2.40	35.3	4.24	2.44
	80	33.6	4.68	2.11	34.0	4.66	2.14	34.4	4.65	2.17
10	60	30.4	3.89	2.29	30.9	3.91	2.32	31.5	3.94	2.35
	70	28.8	4.22	2.00	29.2	4.24	2.02	29.6	4.25	2.04
	80	27.2	4.66	1.71	27.5	4.67	1.72	27.7	4.68	1.74

NOTE: ALL CAPACITIES INCLUDE INDOOR FAN HEAT AT 1250 BTUH/1000 CFM.

Multipliers for determining the performance with other indoor sections.

Air Handler	Coil	MBH	KW	COP
N1AHD2006	G2FD060(S,H)24	1.00	1.00	1.00
N1AHD2006	G2FD061H24	1.02	1.00	1.02
F2FP060		1.01	0.97	1.04
F2FV060		1.00	0.98	1.02
N1VSD20	G2FD060(S,H)24	0.98	1.09	0.91
N1VSD20	G2FD061H24	1.02	1.02	1.00
	G1FA060S21,24	1.00	1.00	1.00
	G1HD060	1.01	1.00	1.01
	G1NA060S24T	1.00	0.97	1.04
	G1UA060S21,24	1.00	1.00	1.00
	G2FD061H24	1.02	1.00	1.02
	G1HA060H24	0.98	0.98	0.99

Variable Speed Furnace	Coil	T.C.	S.C.	KW
P1DUC20V	G1FA060S21	1.00	1.01	0.99
P1XDD20V	G2FD060(S,H)24	1.01	2.29	0.44
P1XUC20V	G1FA060S21	0.99	1.02	0.98
P1XUD20V	G1FA060S24	0.99	1.02	0.98
P1XUD20V	G2FD060(S,H)24	0.99	1.02	0.98
P1XUD20V	G2FD061H24	1.00	1.03	0.97

HEATING PERFORMANCE DATA										
CONDENSING UNIT MODEL NO		E1RC060S25/46								
EVAPORATOR COIL MODEL NO		G1FA060S21								
AIR TEMP. ENTERING OUTDOOR UNIT	AIR TEMP. ENTERING INDOOR COIL	ID CFM								
		1500			1700			1900		
		MBTUH	KW	C.O.P.	MBTUH	KW	C.O.P.	MBTUH	KW	C.O.P.
60	60	71.6	5.22	4.02	72.4	5.14	4.14	73.2	5.05	4.25
	70	70.5	5.66	3.68	70.8	5.56	3.77	71.2	5.45	3.86
	80	69.3	6.10	3.33	69.3	5.98	3.40	69.2	5.85	3.47
47	60	60.0	4.65	3.78	60.4	4.62	3.84	60.7	4.58	3.89
	70	58.8	5.08	3.43	59.0	4.97	3.48	60.0	4.99	3.56
	80	57.6	5.50	3.07	58.5	5.45	3.15	59.3	5.40	3.22
40	60	53.5	4.42	3.55	54.2	4.41	3.61	54.9	4.40	3.66
	70	52.1	4.81	3.20	52.7	4.78	3.26	53.4	4.75	3.32
	80	50.6	5.21	2.85	51.3	5.16	2.92	51.9	5.11	2.98
30	60	46.0	4.19	3.22	46.6	4.18	3.27	47.2	4.17	3.32
	70	44.8	4.58	2.90	45.7	4.56	2.96	46.6	4.55	3.03
	80	43.5	4.96	2.57	44.7	4.95	2.65	46.0	4.94	2.73
17	60	38.0	3.99	2.79	38.4	3.99	2.82	38.8	3.99	2.85
	70	37.0	4.35	2.52	37.0	3.72	2.92	37.9	3.79	2.93
	80	36.0	4.71	2.24	36.5	4.69	2.28	37.0	4.68	2.32
10	60	33.7	3.89	2.56	34.0	3.89	2.58	34.3	3.90	2.60
	70	32.8	4.23	2.31	33.0	4.23	2.33	33.2	4.22	2.35
	80	32.0	4.58	2.06	32.1	4.56	2.08	32.2	4.54	2.10

Multipliers for determining the performance with other indoor sections.

Coil	MBH	KW	COP
G1UA060(S,H)21,24	1.00	1.00	1.00
G1HA060H24	0.99	1.00	0.99
G2FD060(S,H)24	1.00	1.00	1.00

MATCHING INDOOR COMPONENTS

ADD-ON COILS - FOR FURNACE APPLICATIONS

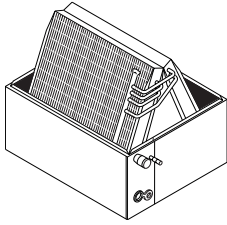

G1UA
1/2 CASED
UPFLOW

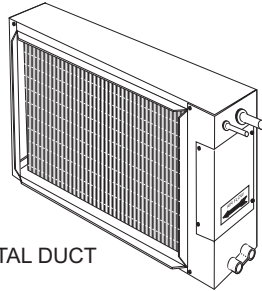

G1HD
HORIZONTAL DUCT

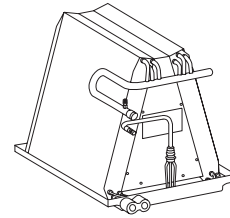

G1NA
UNCASED
UPFLOW

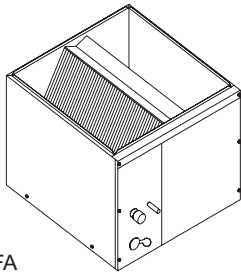

G1FA
FULL CASED
UPFLOW

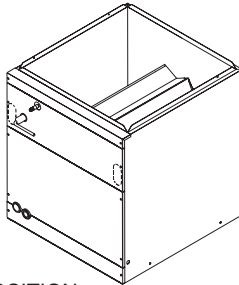

G2FD*
MULTI-POSITION
(UPFLOW, HORIZONTAL
AND DOWNFLOW)

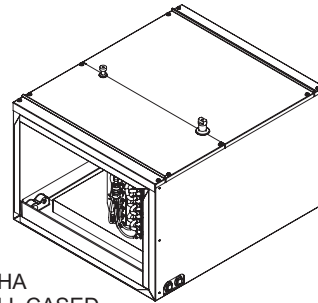

G1HA
FULL CASED
HORIZONTAL

* Available with factory installed horizontal drain pan.

AIR HANDLERS - FOR NON-FURNACE APPLICATIONS

N1AH OR N1VS
MODULAR BLOWER
(UPFLOW, HORIZONTAL
AND DOWNFLOW)

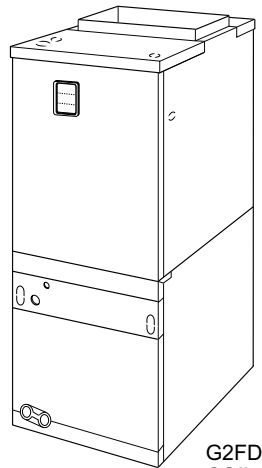

G2FD
COIL

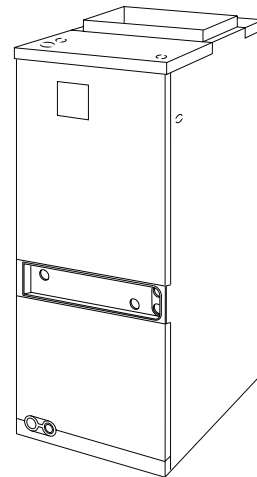

F2RC / F2FC OR
F2RC / F2FP
FAN COIL UNITS
(UPFLOW, HORIZONTAL)