



Heating and Air Conditioning

TECHNICAL GUIDE

SPLIT SYSTEM

AIR COOLED

CONDENSING UNITS

H4CE180 & 240

15 AND 20 NOMINAL TONS

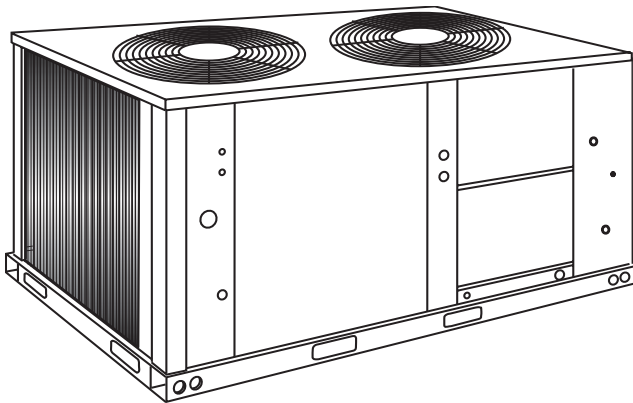

ISO 9001
Certified Quality
Management System



DESCRIPTION

These outdoor condensing units are completely assembled, piped and wired at the factory to provide one-piece shipment and rigging. Each unit is pressurized with a holding charge of Refrigerant-22 for storage and/or shipping.

The compact design, clean styling, and quiet operation make these condensing units suitable for almost any outdoor location. On rooftops . . . because they weigh much less than a single package unit of similar capacity and are much easier to rig and support. At ground level . . . because their ample sub-cooling capacity allows them to be located 18 meters (60 feet) below the evaporator coil.

All sheet metal parts are constructed of commercial grade (G90) galvanized steel. Before painting, each part is thoroughly cleaned to remove any grease or dirt from its surfaces. The external parts are then coated with powder paint to assure a quality finish for many years. This coating system has passed the 750 hour, salt spray test per ASTM Standard B117.

All models include a 1-year limited warranty on the complete unit. The compressor carries an additional 4-year warranty.

A matching line of Evaporator Blower units is also offered to meet your precise capacity and air handling requirements.

FEATURES

- Condenser coil constructed of rifled copper tubes and louvered aluminum fins for durability and long lasting efficient operation.
- Permanently attached base rails with fork lift slots and lifting holes. This design allows for 3-way fork lift access and overhead rigging.
- Both high and low pressure controls.
- Solid state motor protection to prevent the compressor from operating at an unsafe condition.
- Ball bearing condenser fan motors with 5/8 inch shafts.
- Color-coded power and control wiring for easier service and troubleshooting.
- Anti-short cycle timer to protect the compressor.
- A lockout circuit to prevent the unit from cycling on safety control.
- A 24-volt temperature control circuit.
- Standard unit low ambient operation to (35°F).
- A filter-drier (shipped in the unit's compressor compartment for field installation near the evaporator coil).
- Service valves with a back-seating access port for pressure testing the system. Copper stub-outs are factory mounted on the suction and liquid service valves to simplify the field piping connections.
- Separate panel for easy access to the control box without affecting air flow across the condenser coil.
- Exterior access to service pressure port connections.
- Packaging suitable for outdoor storage.
- An optional Phenolic coating is available where the condenser coils are fully dipped in a phenolic coating process to provide longer life in corrosive conditions.

TABLE OF CONTENTS

DESCRIPTION	1
FEATURES	1
FIELD INSTALLED ACCESSORIES	4
SEQUENCE OF OPERATION	9
GUIDE SPECIFICATIONS	10

LIST OF FIGURES

<u>Fig. #</u>	<u>Pg. #</u>
1 UNIT DIMENSIONS AND CLEARANCES	4
2 FIELD WIRING	7

LIST OF TABLES

<u>Tbl. #</u>		<u>Pg. #</u>
1	ARI RATINGS	3
2	UNIT APPLICATION DATA	3
3	PART LOAD CAPACITY AND EFFICIENCY	3
4	PHYSICAL DATA	3
5	ELECTRICAL DATA	3
6	CONDENSING UNIT COOLING CAPACITIES AND POWER REQUIREMENTS	4
7	SYSTEM GROSS COOLING CAPACITIES AND POWER REQUIREMENTS H3CE180 W/K3EU180 ...	5
8	SYSTEM GROSS COOLING CAPACITIES AND POWER REQUIREMENTS H3CE180 W/K3EU180 ..	6
9	SUCTION LINE DATA	8
10	LIQUID LINE DATA	8
11	REFRIGERANT LINE CHARGE	8

TABLE 1: ARI RATINGS

CONDENSING UNIT	AIR HANDLER	NET CAPACITY MBH (1)	EER (1)	IPLV (1)	COND. UNIT SOUND DB(2)	RATED AIR FLOW CFM	RATED EXT. STATIC PRESS IN WC
H3CE150	K3EU180	136	8.8	10.1	91.0	5000	0.35
H3CE180	K3EU180	192	8.7	10.8	91.0	6000	0.35
H3CE240	L4EU240	234	8.8	11.0	89.0	8000	0.40

1. Rated in accordance with ARI 360.
2. Rated in accordance with ARI 370.
3. All ratings were determined with 25 feet of interconnecting tubing and with the air handler in the horizontal position.
For the 180, a 5/8" liquid line and an insulated 1-5/8" suction line were used.
For the 240, a 7/8" liquid line and an insulated 2-1/8" suction line were used.
4. For 208V operation, derate the 180 and 240 capacity 1% and add 2dB to H3CE240 sound rating.

TABLE 2: UNIT APPLICATION DATA

Voltage Variation ¹ Min. / Max.	208/230-3-60	187 / 252
	460-3-60	432 / 504
	575-3-60	540 / 630
Ambient Air on Condenser Coil Min. / Max.		35°F2 / 115°F
Ambient Air on Condenser Coil Min. / Max. with Head Pressure Control		0 - 115°F

1. Utilization range "A" in accordance with ARI Standard 110.
2. The minimum allowed ambient temperature for mechanical cooling without the head pressure control accessory installed must be raised if the indoor air flow is less than the minimum value given in the capacity tables.

TABLE 3: PART LOAD CAPACITY AND EFFICIENCY

CONDENSING UNIT	AIR HANDLER	SINGLE COMPRESSOR NET CAPACITY MBH	EVAPORATOR					CONDENSER ENTERING DRY BULB °F
			IPLV	AIR FLOW CFM	ENTERING DRY BULB °F	ENTERING WET BULB °F	RATED EXT. STATIC PRESS IN WC	
H3CE150	K3EU180	83.7	10.1	5000	80	67	0.35	80
H3CE180	K3EU180	123.8	10.8	6000	80	67	0.35	80
H3CE240	L4EU240	133.7	11.0	800	80	67	0.4	80

TABLE 4: PHYSICAL DATA

MODEL SIZE (MBH)	COMPRESSOR ¹		CONDENSER									UNIT WEIGHT (LBS.)		CHARGE (REFRIGERANT-22 - LBS.OZ.)	
			24" FAN (PROPELLER)			FAN MOTOR ²				COIL					
	RATING (TONS)	CAP. (STG'S.)	QTY.	BLADES/PITCH (DEG.)	NOM. CFM	QTY.	HP	RPM	ROTATION	FINS PER INCH	ROWS DEEP	SHIP.	OPER.	HOLDING ³	OPER ⁴
180	15	2	2	3/34	10,800	2	1	1100	CCWLE	20	2	920	930	1-0	25-0
240	20	2	2	3/34	11,300	2	1	1100	CCWLE	20	2	970	990	1-0	37-0

1. Compressor set consists of two Copeland Scroll compressors manifolded into a single refrigerant circuit.
2. The ball bearing, 48 frame, single phase condenser fan motor have internal protection that is directly connected to the condenser fans. Motor rotation is counter-clockwise when viewing the lead end, which is opposite the shaft end.
3. Holding charge is the amount in the unit as shipped from the factory.
4. Operating refrigerant charge is for the condensing unit and the matching York air handler, but does not include the charge in the interconnecting piping. See the refrigerant line charge table to determine the additional refrigerant charge required for the interconnecting piping.

TABLE 5: ELECTRICAL DATA

MODEL	UNIT POWER SUPPLY	COMPRESSOR ¹			CONDENSER FAN MOTOR			UNIT	
		QTY.	RLA	LRA	QTY.	HP	FLA	MINIMUM CIRCUIT AMPACITY (AMPS)	MAXIMUM FUSE SIZE ² (AMPS)
HCE180A25	208/230/3/60	2	32.1	195	2	1	4.7	81.6	110
HCE180A46	460/3/60	2	16.4	95	2	1	2.5	41.9	50
HCE180A58	575/3/60	2	12.0	80	2	1	2.0	31.2	40
HCE240A25	208/230/3/60	2	42.0	239	2	1	4.7	103.9	125
HCE240A46	460/3/6/60	2	19.2	125	2	1	2.5	48.2	60
HCE240A58	575/3/60	2	13.8	80	2	1	2.0	35.0	45

1. The 208-230 V compressors and motors use a single tap for the entire range of voltages. The 208/230 V to 24 V transformers have different taps for 208 and 230 V.
2. Dual element, time delay type.

FIELD INSTALLED ACCESSORIES

- 0°F LOW AMBIENT - A single phase condenser fan motor and head pressure control to reduce its speed maintain stable system operation at ambient temperatures down to 0°F.
- Coil Guard - A decorative coil guard provides an additional level of protection for the condenser coils.

Low Ambient Cooling

The following accessories are available to provide low ambient operation to 0°F:

2LA04704225	208/230 VOLTS
2LA04704346	460 VOLTS
2LA04704458	575 VOLTS

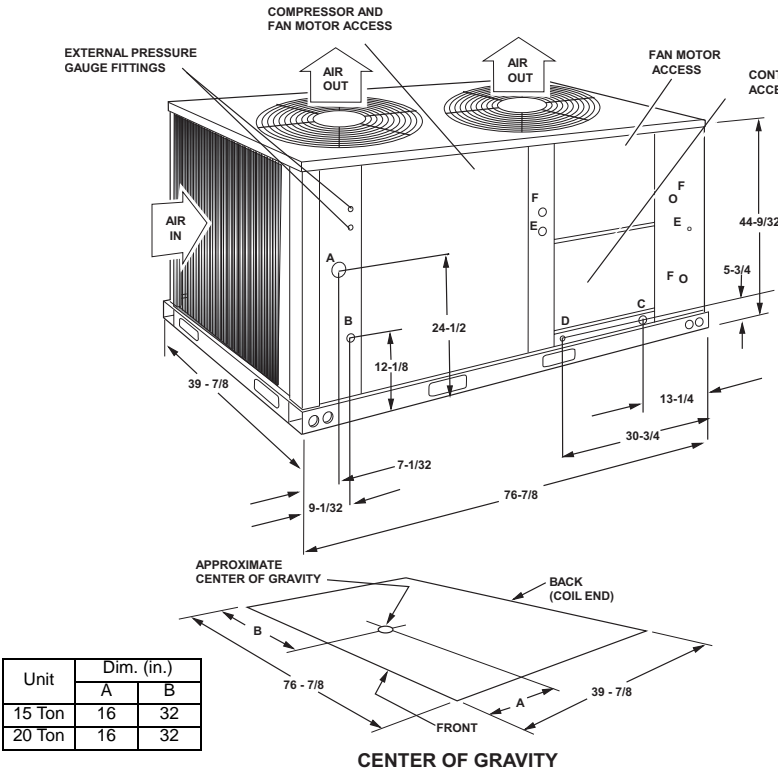

All dimensions are in inches. They are subject to change without notice. Certified dimensions will be provided upon request.

Connection Entry	Connection Size	
	15 Ton	20 Ton
Suction Line	A 1-5/8 ID	2-1/8 ID
Liquid Line	B 5/8 ID	5/8 ID
Power Wiring	C 2-1/8 KO	2-1/8 KO
Control Wiring	D 7/8 KO	7/8 KO
Accessory Wiring	E 7/8 KO	7/8 KO
Accessory Wiring	F 1-3/8 KO	1-3/8 KO

CLEARANCES

Overhead (Top) ¹	120"
Front (Piping and Access Panels)	30"
Left Side	24"
Right Side	24"
Rear	24"
Bottom ²	0"

1. Units must be installed outdoors. Overhanging structures or shrubs should not obstruct condenser air discharge.
2. Adequate snow clearance must be provided if winter operation is expected.

FIGURE 1 - UNIT DIMENSIONS AND CLEARANCES

TABLE 6: CONDENSING UNIT COOLING CAPACITIES AND POWER REQUIREMENTS

MODEL	COMPRESSOR SUCTION		AMBIENT TEMPERATURE ENTERING CONDENSER COIL (°F)											
	PRESSURE (PSIG)	SATURATED TEMP (°F)	65		75		85		95		105		115	
			MBH ¹	kW ²	MBH	kW	MBH	kW	MBH	kW	MBH	kW	MBH	kW
180	54.9	30	155	13.2	147	14.2	138	154	130	16.7	122	18.2	114	20.0
	61.6	35	169	13.561	161	14.5	152	15.7	144	17.0	135	18.5	126	20.3
	68.5	40	184	13.8	175	14.8	166	16.0	157	17.3	148	18.9	139	20.6
	76.0	45	200	14.1	191	15.2	181	16.3	172	17.7	162	19.2	153	21.0
	84.0	50	217	14.5	207	15.5	197	16.7	187	18.1	177	19.6	167	21.4
240	54.9	30	199	16.5	189	18.2	179	20.0	169	21.9	159	24.1	149	26.5
	61.6	35	218	16.8	207	18.5	196	20.3	186	22.3	175	24.5	164	26.9
	68.5	40	238	17.1	226	18.8	215	20.6	203	22.7	192	24.9	180	27.4
	76.0	45	258	17.5	246	19.1	234	21.0	221	23.1	209	25.4	196	27.9
	84.0	50	280	17.8	266	19.5	253	21.4	240	23.5	226	25.8	213	28.4

1. Capacities are net ratings.
 2. Power is for the condensing unit only.

TABLE 7: SYSTEM GROSS COOLING CAPACITIES AND POWER REQUIREMENTS H3CE180 W/K3EU180

AIR ENT. EVAPORATOR		AIR TEMPERATURE ENTERING EVAPORATOR, DRY BULB																	
CFM	WB	POWER INPUT KW	85°F AIR ENTERING CONDENSER								POWER INPUT KW	95°F AIR ENTERING CONDENSER							
			86		80		74		68			86		80		74		68	
			TOTAL	SENS	TOTAL	SENS	TOTAL	SENS	TOTAL	SENS		TOTAL	SENS	TOTAL	SENS	TOTAL	SENS	TOTAL	SENS
7200	72	15.6	205	154	204	115	201	77			17.2	198	151	196	112	193	74		
	67	15.4	197	188	191	149	188	110	185	71	16.9	191	185	183	145	182	108	179	68
	62	15.3	197	197	183	182	176	144	174	106	16.9	191	191	179	179	170	142	168	103
	57	15.3	197	197	182	182	172	172	163	140	16.9	191	191	179	179	167	167	157	136
6600	72	15.5	203	148	202	112	199	75			17.2	196	145	194	109	192	73		
	67	15.4	193	180	189	143	187	108	184	70	16.9	187	177	182	140	180	105	177	67
	62	15.2	193	193	181	174	174	139	172	103	16.8	187	187	175	172	168	136	166	100
	57	15.2	193	193	181	181	169	169	160	134	16.8	187	187	175	175	164	164	155	132
6000	72	15.5	201	142	200	108	197	74			17.1	194	139	192	106	190	71		
	67	15.3	189	172	187	137	185	105	182	69	16.9	184	170	180	134	178	102	175	66
	62	15.2	188	188	177	168	172	134	170	101	16.8	183	183	171	164	166	131	164	98
	57	15.2	188	188	177	177	164	162	158	129	16.8	183	183	171	171	159	158	152	126
5400	72	15.5	199	135	197	105	195	72			17.1	192	133	190	102	188	70		
	67	15.3	186	163	184	131	182	101	180	68	16.9	180	160	178	129	176	99	173	66
	62	15.1	183	183	173	160	170	128	168	98	16.7	178	178	167	156	163	125	162	95
	57	15.1	183	183	172	172	160	155	156	124	16.7	178	178	167	167	155	152	150	121
4800	72	15.4	196	129	194	101	192	71			17.0	189	126	187	98	185	68		
	67	15.2	183	154	181	125	179	98	177	67	16.8	177	151	175	122	173	95	170	65
	62	15.0	177	177	169	150	166	122	165	95	16.6	172	172	163	147	160	119	159	92
	57	15.0	177	177	166	166	156	147	153	118	16.6	172	172	161	161	151	143	147	115

AIR ENT. EVAPORATOR		AIR TEMPERATURE ENTERING EVAPORATOR, DRY BULB																	
CFM	WB	POWER INPUT KW	105°F AIR ENTERING CONDENSER								POWER INPUT KW	115°F AIR ENTERING CONDENSER							
			86		80		74		68			86		80		74		68	
			TOTAL	SENS	TOTAL	SENS	TOTAL	SENS	TOTAL	SENS		TOTAL	SENS	TOTAL	SENS	TOTAL	SENS	TOTAL	SENS
7200	72	19.0	190	148	188	109	185	72			21.0	182	146	180	106	177	69		
	67	18.7	184	181	176	142	174	104	171	65	20.8	177	177	169	140	166	101	163	63
	62	18.7	184	184	172	172	163	139	161	100	20.7	177	177	166	166	156	135	153	96
	57	18.7	184	184	172	172	161	161	151	133	20.7	177	177	166	166	155	155	144	129
6600	72	19.0	188	142	186	106	184	70			21.0	180	139	178	103	175	67		
	67	18.7	180	173	175	137	172	102	170	65	20.7	173	170	167	134	165	98	162	62
	62	18.6	180	181	169	167	161	133	159	97	20.6	173	173	163	163	155	130	152	94
	57	18.6	180	181	169	169	158	158	149	129	20.6	173	173	163	163	152	152	142	125
6000	72	18.9	186	136	184	102	182	69			21.0	178	133	176	99	174	66		
	67	18.7	177	166	173	131	171	99	168	64	20.7	170	162	165	128	163	95	161	61
	62	18.6	176	176	165	161	159	128	158	95	20.6	170	170	159	157	152	124	151	92
	57	18.6	176	176	165	166	155	155	146	123	20.6	170	170	159	159	149	149	141	120
5400	72	18.9	184	129	183	99	180	67			20.9	176	127	175	96	172	65		
	67	18.6	173	157	171	125	169	96	166	63	20.6	167	154	163	122	161	92	159	60
	62	18.5	172	172	161	153	157	122	155	92	20.5	166	166	155	149	150	119	149	89
	57	18.5	172	172	161	161	150	148	144	118	20.5	166	166	155	155	144	144	138	115
4800	72	18.9	181	123	180	96	177	66			20.9	174	120	172	92	170	63		
	67	18.6	170	148	168	119	166	92	164	62	20.6	163	145	161	116	159	89	157	59
	62	18.4	166	166	157	144	154	116	153	89	20.4	161	161	152	142	148	113	146	86
	57	18.4	166	166	156	156	146	140	142	112	20.4	161	161	151	151	140	138	136	109

Notes:

1. Capacities are gross MBH.
2. Temperatures are expressed in °F.
3. Power (kW) is for the condensing unit only and corresponds to 80°F dry bulb air temperature entering the evaporator.
4. Air handler power is not included.
5. Shaded areas represent dry coil operation.

 All Sensible Capacity

3.415 MBH

Blower Motor KW x KW = Blower Motor Heat (MBH)

TABLE 8: SYSTEM GROSS COOLING CAPACITIES AND POWER REQUIREMENTS H3CE180 W/K3EU180

AIR ENT. EVAPORATOR		AIR TEMPERATURE ENTERING EVAPORATOR, DRY BULB																	
CFM	WB	POWER INPUT KW	85°F AIR ENTERING CONDENSER								POWER INPUT KW	95°F AIR ENTERING CONDENSER							
			86		80		74		68			86		80		74		68	
			TOTAL	SENS	TOTAL	SENS	TOTAL	SENS	TOTAL	SENS		TOTAL	SENS	TOTAL	SENS	TOTAL	SENS	TOTAL	SENS
9600	72	22.8	279	204	277	153	273	104			25.2	268	200	266	149	262	100		
	67	22.3	265	251	259	197	257	148	252	96	24.8	255	246	249	193	246	143	242	92
	62	22.2	265	265	248	245	240	192	237	142	24.7	255	255	244	244	230	187	227	137
	57	22.2	265	265	248	248	237	237	221	185	24.6	255	255	244	244	229	229	212	181
8800	72	22.7	277	196	274	149	270	102			25.1	266	192	264	145	259	98		
	67	22.3	261	240	257	190	254	144	250	95	24.7	252	237	247	186	244	140	240	91
	62	22.0	261	261	243	234	237	185	235	138	24.5	252	252	235	231	228	181	225	134
	57	22.0	261	261	243	243	232	232	218	179	24.5	252	252	235	235	224	224	210	174
8000	72	22.6	274	188	271	144	267	100			25.1	263	184	261	141	257	96		
	67	22.2	257	229	254	182	251	140	247	93	24.6	247	225	244	179	241	136	237	90
	62	21.9	257	257	239	224	234	178	232	135	24.4	247	247	230	220	225	174	223	130
	57	21.9	257	257	239	239	221	216	216	173	24.4	247	247	230	230	215	213	207	169
7200	72	22.5	270	180	268	140	264	98			25.0	260	176	257	136	254	94		
	67	22.1	253	218	250	175	247	136	244	92	24.5	243	214	241	171	238	132	234	89
	62	21.7	250	250	234	213	230	171	228	131	24.2	242	242	225	208	222	167	219	127
	57	21.7	250	250	234	234	217	207	212	166	24.2	242	242	225	225	209	203	204	162
6400	72	22.4	266	171	263	135	260	96			24.9	256	168	253	131	250	92		
	67	22.0	247	205	246	167	243	131	240	91	24.4	239	202	237	163	234	127	230	87
	62	21.6	242	242	229	202	226	163	224	127	24.0	234	234	220	197	218	160	215	123
	57	21.6	242	242	227	227	211	196	208	159	24.0	234	234	220	220	203	192	200	155

AIR ENT. EVAPORATOR		AIR TEMPERATURE ENTERING EVAPORATOR, DRY BULB																	
CFM	WB	POWER INPUT KW	105°F AIR ENTERING CONDENSER								POWER INPUT KW	115°F AIR ENTERING CONDENSER							
			86		80		74		68			86		80		74		68	
			TOTAL	SENS	TOTAL	SENS	TOTAL	SENS	TOTAL	SENS		TOTAL	SENS	TOTAL	SENS	TOTAL	SENS	TOTAL	SENS
9600	72	27.9	257	196	255	145	250	96			31.0	245	191	243	141	238	93		
	67	27.4	246	242	239	189	236	139	231	88	30.4	241	241	228	185	225	134	220	84
	62	27.4	246	246	235	235	220	183	218	132	30.4	241	241	226	226	210	179	207	128
	57	27.4	246	246	235	235	220	220	203	176	30.4	241	241	226	226	210	210	194	172
8800	72	27.9	255	188	252	141	248	94			30.9	243	184	241	136	237	91		
	67	27.4	242	232	237	182	234	135	229	87	30.3	232	227	226	178	223	131	219	83
	62	27.2	242	242	231	231	218	176	216	129	30.2	232	232	221	221	208	172	206	125
	57	27.2	242	242	231	231	216	216	201	170	30.2	232	232	221	221	207	207	192	166
8000	72	27.8	252	180	250	136	246	92			30.8	241	177	238	132	234	89		
	67	27.3	238	221	234	174	231	131	227	86	30.3	228	217	223	170	220	127	216	82
	62	27.1	238	238	221	214	215	169	213	126	30.1	228	228	217	217	206	165	203	122
	57	27.1	238	238	221	221	211	211	198	164	30.1	228	228	217	217	203	203	189	159
7200	72	27.7	249	172	247	132	243	90			30.7	238	168	235	128	232	87		
	67	27.2	234	210	231	166	228	127	224	85	30.2	223	205	220	162	218	123	214	81
	62	26.9	234	234	217	204	212	162	210	123	29.9	223	223	208	199	203	158	201	118
	57	26.9	234	234	217	217	202	199	195	157	29.9	223	223	211	211	198	198	187	152
6400	72	27.6	245	163	243	127	239	88			30.6	234	159	232	123	229	85		
	67	27.1	229	197	227	159	224	123	221	84	30.1	219	193	217	154	214	119	211	80
	62	26.7	226	226	211	192	209	155	207	119	29.7	218	218	202	187	199	150	197	114
	57	26.7	226	226	211	211	196	188	192	150	29.7	218	218	202	202	188	182	183	146

Notes:

1. Capacities are gross MBH.
2. Temperatures are expressed in °F.
3. Power (kW) is for the condensing unit only and corresponds to 80°F dry bulb air temperature entering the evaporator.
4. Air handler power is not included.
5. Shaded areas represent dry coil operation.

3.415 MBH All Sensible Capacity

Blower Motor KW x **3.415 MBH** = Blower Motor Heat (MBH)

H3CE150/K3EU180

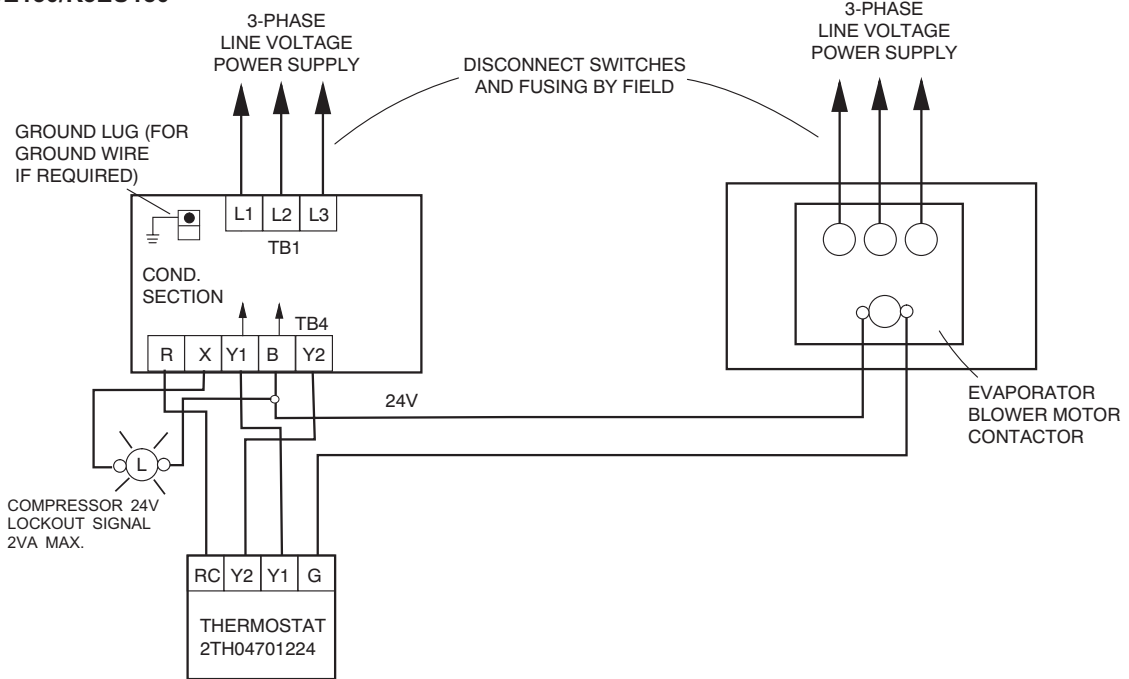

H3CE240/L3EU240

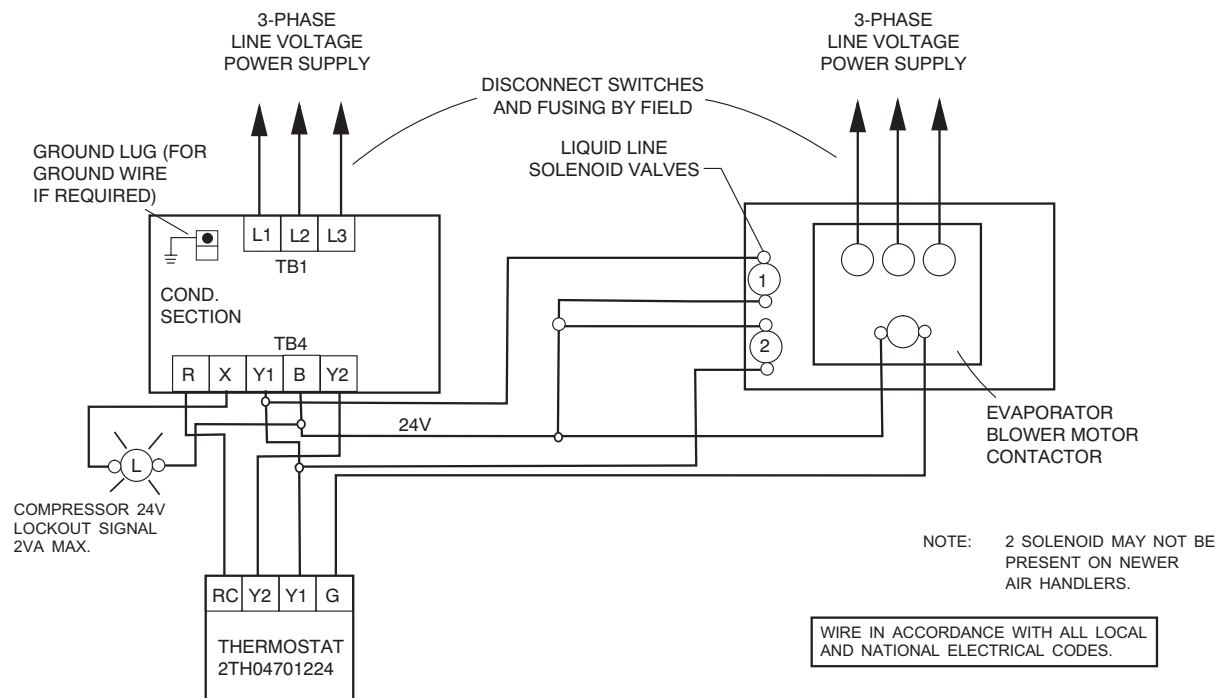

FIELD WIRING:
LOW VOLTAGE CLASS 2 WIRING
LINE VOLTAGE CLASS 1 WIRING

FIGURE 2 - FIELD WIRING

TABLE 9: SUCTION LINE DATA^{1, 2}

MODEL DESIGNATION		NOMINAL CAPACITY (TONS)	REFRIGERANT FLOW RATE ³ (LBS./MIN.)	TYPE L COPPER TUBING (INCHES O.D.)	REFRIGERANT GAS VELOCITY (FT./MIN.)	FRICTION LOSS ^{4, 5} (PSI/100 FT.)
HCE180	Full Capacity	15	45	1-5/8 2-1/8	2300 1360	2.5 0.6
	Part Capacity	8-1/2	25.5	1-5/8 2-1/8	1150 770 ⁶	0.7 0.2
HCE240	Full Capacity	20	60	1-5/8	3120	4.3
				2-1/8	1800	1.2
				2-5/8	1200	0.4
	Part Capacity	10	30	1-5/8 2-1/8 2-5/8	1560 900 ⁶ 600 ⁶	1.2 0.3 0.1

1. All horizontal suction lines should be pitched at least 1: every 20 feet in the direction of the refrigerant flow to aid the return of oil to the compressor.
2. Every vertical suction riser greater than 25 feet in height should have a "P" trap at the bottom to facilitate the return of oil to the compressor. Use short radius fittings for these traps.
3. Based on Refrigerant-22 at the nominal capacity of the condensing unit, a suction temperature of 40°F and a liquid temperature of 105°F
4. Although suction lines should be sized for a friction loss equivalent to a 2°F change in saturation temperature (or approximately 3 psi), sizing the lines for the proper return of oil is more important.
5. These friction losses do not include any allowances for valves or fittings.
6. Since the refrigerant gas velocity may be too low to maintain good oil return up a vertical riser, use the next smaller size. The larger size may be used for horizontal runs for a smaller pressure drop.

TABLE 10: LIQUID LINE DATA

MODEL	NOMINAL CAPACITY	REFRIGERANT FLOW RATE ¹ (LBS./MIN.)	TYPE L COPPER TUBING (INCHES/O.D.)	PRESSURE DROP ²	
				FRICTION ³ (PSI/100 FT.)	VERTICAL RISE (PSI/FT.)
HCE180	15	45	3/4 7/8	4.7	0.5
				2.2	
HCE240	20	60	3/4 7/8	8.0	0.5
				3.5	

1. Based on Refrigerant-22 at the nominal capacity of the condensing unit, a liquid temperature of 105°F and a suction temperature of 40°F
2. These friction losses do not include any allowances for a strainer, filter-drier, solenoid valve, isolation valve or fittings.
3. The total pressure drop of the liquid line for both friction and vertical rise must not exceed 40 PSI. If the pressure drop exceeds 40 PSI, the liquid refrigerant could flash before it reaches the expansion valve. This flashing will not only cause erratic valve operation and poor system performance, but could also damage the expansion valve.

TABLE 11: REFRIGERANT LINE CHARGE¹

Liquid Lines ² Inches, O.D.	5/8	0.113 lb./ft.
	7/8	0.237 lb./ft.
Suction Line ² Inches, O.D.	1-5/8	0.018 lb./ft.
	2-1/8	0.031 lb./ft.
	2-5/8	0.047 lb./ft.

1. Charges are based on 40°F suction temperature and a 105°F liquid temperature.
2. Type "L" copper tubing.

NOTE: Add the operating charge of the condensing unit, the evaporator coil and the refrigerant lines to determine the total refrigerant charge of the system.

SEQUENCE OF OPERATION

FIRST STAGE OF COOLING

A call for cooling at terminal Y1 energizes relay RY1. Relay RY1 closes contacts RY1-1, energizing time delay relay 3TR. If time delay relay 3TR is satisfied as described below, it will energize its output terminal Y2, which is connected to compressor 1 control module terminal M1.

If the compressor 1 control module is satisfied as described below, it will apply power to terminal 7 of low or high pressure lock out relay (LOR) contacts. See a description of the LOR operation below. If the LOR coil is not energized (not locked out), the LOR contacts will be closed, energizing contactor 1M, which powers compressor 1 and condenser fan motor 1.

When 1M is energized on H3CE240 units, auxiliary contact 1M-AC2 is closed, powering terminal 1 for opening the stage 1 solenoid in air handlers which feature a stage 1 solenoid.

If the low ambient temperature switch TLA is closed, it will allow condenser fan 2 contactor 3M to energize. TLA opens as the temperature falls below 50 °F and closes as the ambient rises above 60 °F. TLA is used on the H3CE180, not the H3CE240.

ANTI-SHORT CYCLE TIME DELAY RELAYS 3TR AND 4TR

Relay 3TR, which serves compressor 1 control, has an adjustable low voltage lock out which is set at 20V in the factory. The voltage applied to 3TR must be above its lock out setting and 5 minutes must elapse since the relay was last energized before it will energize its output terminal Y2. Relay 4TR is identical but it serves compressor 2 control.

COMPRESSOR CONTROL MODULE

If the compressor control module terminals L1 (or T1) and L2 (or T2) have 24 V applied and the internal compressor temperature lock out is inactive, the internal switch connecting M1 and M2 will be closed. M1 to M2 will open if one of the compressor's internal temperature sensors exceeds its limit. M1 to M2 stays open for 30 minutes after an internal temperature limit is exceeded. The 30 minute lock out may be reset prior to the 30 minutes expiring by removing power to the control module terminals L1 and L2. During normal operation, each compressor control module should always be powered at the L1 and L2 terminals, whether there is a call for cooling or not.

LOW OR HIGH PRESSURE LOCK OUT OPERATION

If the lock out circuit path is opened during a call for cooling, the lock out relay (LOR) coil will energize, opening LOR-1 contacts and disabling all compressor operation. The lock out circuit path is open if:

- the lock out relay contacts LOR-1 are open, OR
- the low pressure switch LP is open AND the low pressure switch bypass timer contacts 1TR-1 are open, OR
- the high pressure switch HP is open.

Once the LOR coil has been energized, it remains energized, locking out cooling operation until the call for cooling has been removed. When Y1 is returned to 0 volts, the LOR coil is no longer energized, closing the LOR-1 contacts and removing the lock out.

The low pressure bypass timer 1TR leaves the 1TR-1 contacts closed upon the start of a call for cooling until its 90 second (nominal) timer has expired. This bypasses the low pressure switch during start up. After the time delay has elapsed, 1TR-1 contacts are opened, once again allowing low pressure to trigger the lock out circuit if the low pressure switch opens.

During a lock out, the LOR-2 contacts are closed, energizing the X terminal on the terminal board for lighting a lock out warning light.

RESETTING THE LOCK OUT

The lock out may be reset by:

- Turning the thermostat switch to OFF, or
- Momentarily adjusting the cooling set point to its maximum allowed value.

If the unit does not resume operation after the anti-short cycle timer expires or if it continues to lock out after resuming operation, call a service technician to diagnose and repair the unit.



Repeatedly resetting the lock out may cause damage to the unit.

SECOND STAGE OF COOLING

The second stage of cooling will only be enabled if the first stage of cooling is on, closing auxiliary contact 1M-AC1. A call for cooling at terminal Y2 energizes Relay RY2, closing contact RY2-1, and energizing time delay relay 4TR if contact 1M-AC1 is closed. If time delay relay 4TR is satisfied, it will energize its output terminal Y2, which is connected to compressor 2 control module terminal M1.

If the compressor 2 control module is satisfied, it will energize time delay relay TDR. After 4 seconds, TDR energizes compressor 2 contactor 2M. When 2M is energized on H3CE240 units, auxiliary contact 2M-AC1 is closed, powering terminal 2 for opening the stage 2 solenoid in air handlers which feature a stage 2 solenoid.

GUIDE SPECIFICATIONS - H*CE 180 THRU 240

I. General

- A. Units shall be manufactured in a facility registered under the ISO 9002 manufacturing quality standard.
- B. Units shall be UL listed to US and Canadian safety standards.
- C. Unit shall be packaged to allow outdoor storage.
- D. Warranty shall be a full year limited parts warranty on the complete unit with an additional 4-year warranty on the compressor.
- E. Unit shall be rated in accordance with ARI 360.

II. Unit Cabinet

- A. Cabinet shall be constructed of 18 gauge, zinc-coated steel, finished with a powder paint process capable of withstanding a minimum of 750 salt spray hours according to ASTM B117.
- B. Cabinet screws shall comply with the ASTM B117 salt spray test for a minimum of 750 hours.
- C. Panels shall be removable for easy access to all internal components during maintenance and service.
- D. Cabinet shall feature a separate access panel for the controls so that unit airflow need not be disturbed during servicing.
- E. Permanently attached base rails shall have 3-way fork lift access and lifting holes for ease of installation.

III. Compressor

- A. Compressors shall be hermetic scroll.
- B. Compressor shall feature motor overload protection.
- C. A crankcase heater shall keep refrigerant from diluting the compressor oil in the sump. Crankcase heater shall be field replaceable without removal of the charge.
- D. Neoprene isolators shall be used to minimize the transmission of sound and vibration.
- E. Compressor sets shall have two stages, with unloading accomplished through turning off one compressor.

IV. Condenser and Fans

- A. Fan motors shall be direct-drive with propeller-type condenser fans which discharge air vertically upward.

- B. Fan motors shall have permanently lubricated ball-bearings for longer wear during start and stop cycles and shall have inherent overload protection.
- C. Coil shall be constructed of rifled copper tubing mechanically expanded and bonded to louvered aluminum fins. Coil shall include an integral subcooler.

V. Refrigeration Components - Refrigeration system shall contain the following:

- High and low pressure cut-outs
- Suction and liquid line service valves to ease installation and recovery of refrigerant
- External ports to accommodate gauge lines, allowing for easy servicing
- Filter drier shipped in unit for field installation
- Holding charge of Refrigerant-22

VI. Controls - Unit controls shall include:

- A. 24 volt control circuit with terminal blocks.
- B. Color-coded wiring for easy service and troubleshooting
- C. Independent line break thermal protection for the condenser fans.
- D. 5 minute anti-short cycle timer to protect the compressor from frequent cycling.
- E. Unit safety lockouts which automatically reset from the thermostat once the anti-short cycle timer is satisfied. Safety lockouts will also generate a 24 volt signal to the "X" terminal, allowing notification to the user via the thermostat fault light (if present). These safety lockouts shall include:
 1. High refrigerant pressure
 2. Low refrigerant pressure. Low refrigerant pressure shall be bypassed for the first 120 seconds (approximate) of operation to eliminate nuisance trips.
- F. Compressor motor protection to automatically shut-down the unit in the event of motor overcurrent or low control voltage conditions. Unit shall automatically restart after satisfying the anti-short cycle timer.
- G. Low ambient operation down to 35 °F without a low ambient kit. (Operation down to 0 °F with the optional low ambient kit.)

VII. Electrical

- A. Units shall be _____ volts, 3 phase, with a single power point connection.
- B. Unit control circuit shall have a 24 volt transformer, sized sufficiently to operate the indoor fan.
- C. All condenser fan motors and the secondary of each transformer shall be grounded.

VIII. Accessories and Options

- A. **Head Pressure**
Control Shall include a condenser fan motor and a pressure controller, allowing operation of the condensing unit down to 0°F.
- B. **Coil Guard**
Field installed decorative grille shall be placed on the units to provide further coil protection.
- C. **Phenolic Coating on Condenser Coil**
Condenser coils shall be dipped in a four-coat phenolic coating process to provide longer life in corrosive conditions.

Subject to change without notice. Printed in U.S.A.
Copyright © by Unitary Products Group 2003. All rights reserved.

036-21532-001-A-0303
Supersedes: 550.23-TG3Y (0601)

**Unitary
Products
Group**

**5005
York
Drive**

**Norman
OK
73069**