



# YORK®

## Heating and Air Conditioning

### TECHNICAL GUIDE

**AFFINITY**  
**SPLIT-SYSTEM AIR CONDITIONERS**  
**13 SEER**  
**MODELS:**  
**CZB024 THRU 060**  
**(2 THRU 5 NOMINAL TONS)**



Due to continuous product improvement, specifications are subject to change without notice.

Visit us on the web at [www.york.com](http://www.york.com) for the most up-to-date technical information.

Additional rating information can be found at [www.ariprimer.net.org](http://www.ariprimer.net.org).

### DESCRIPTION

The CZB Series condensing unit is the outdoor part of a versatile system of air conditioning. It is designed to be custom matched with one of our complete line of evaporator sections, each designed to serve a specific function. Matching air handlers are available for Upflow, Downflow and Horizontal Left or Right application to provide a complete system. Electric Heaters are available if required. Add-on coils are available for use with upflow, downflow or horizontal furnaces. Field installed accessories are available as needed.

### WARRANTY

*5-year limited parts warranty.*

*10-year limited compressor warranty.*

### FEATURES

- **Superior Coil Protection** – A stamped decorative metal coil guard completely protects coil from debris and other large damaging material while a polymer mesh further protects the coil against smaller particles.
- **Isolated Compressor Compartment** – A molded composite bulkhead isolates the compressor from the rest of the unit reducing sound and vibration.
- **Protected Compressors** – Each compressor is protected against high and low pressure as well as excessive temperature. This is accomplished by the simultaneous operation of high pressure relief valve and temperature sensors which protect the compressor if undesirable conditions occur. A factory installed liquid line filter drier further protects the compressor.
- **Environmentally Friendly Refrigerant** – Next generation refrigerant R-410A delivers environmentally friendly performance with zero ozone depletion.
- **Durable Finish** – Automotive quality finish provides the ultimate protection from harmful U.V. rays as well as rust creep ensuring long-lasting high quality appearance. A powder-paint topcoat is applied over a baked-on primer, using a galvanized, zinc coated steel base material. The result is a finish that has been proven in testing to provide 33% greater durability than conventional powder-coat finishes.
- **Lower Installed Cost** – Designed to provide enhanced installability by featuring a slide-down control compartment allowing easy access to control components along with angled service valves to reduce overall installation time and cost.
- **Low Operating Sound Levels** – A fan design boasting technology adapted from aeronautic and defense engineering provides for whisper quiet operation by allowing airflow to flow smoothly and efficiently across the fan tips.
- **Filter-Drier** – A factory installed, solid core liquid line filter-drier filters harmful debris and moisture from the system.
- **Easy Service Access** – A full end, full service, access panel with handle makes for easy entry to internal components.
- **Long Lasting Operation** – Strong and durable composite base pan provides added strength while resisting rust and corrosion as well as reducing sound and vibration.

Certified in accordance with the Unitary Small Equipment certification program, which is based on ARI Standard 210/240.

**PHYSICAL AND ELECTRICAL DATA**

MODEL		CZB02411	CZB03011	CZB03611	CZB04211	CZB04811	CZB06011
Unit Supply Voltage		208-230/1/60					
Normal Voltage Range <sup>1</sup>		187 to 252					
Minimum Circuit Ampacity		16.5	18.9	22.3	28.7	27.9	34.4
Max. Overcurrent Device Amps <sup>2</sup>		25	30	35	50	45	60
Compressor Type		Scroll	Scroll	Scroll	Scroll	Scroll	Scroll
Compressor Amps	Rated Load	14.3	16.4	16.6	21.8	21.1	26.3
	Locked Rotor	60	73	88	105	113	150
Crankcase Heater		No	No	No	No	No	No
Fan Motor Amps	Rated Load	0.5	0.5	1.5	1.5	1.5	1.5
Fan Diameter Inches		22	22	22	22	22	22
Fan Motor	Rated HP	1/15	1/15	1/4	1/4	1/4	1/4
	Nominal RPM	850	850	850	850	850	850
	Nominal CFM	2,250	2,300	3,200	3,250	3,500	3,500
Coil	Face Area Sq. Ft.	14.86	17.15	17.15	20.58	20.58	20.58
	Rows Deep	1	1	1	1	1	2
	Fins / Inch	22	22	22	22	22	22
Liquid Line OD		3/8	3/8	3/8	3/8	3/8	3/8
Vapor Line OD		3/4	3/4	7/8	7/8	7/8	7/8
Unit Charge (Lbs. - Oz.) <sup>3</sup>		6-4	7-4	6-15	8-13	8-12	13-9
Charge Per Foot, Oz.		0.62	0.62	0.67	0.67	0.67	0.67
Operating Weight Lbs.		170	190	190	205	215	260

1 Rated in accordance with ARI Standard 110, utilization range "A".

2 Dual element fuses or HACR circuit breaker.

3 The Unit Charge is correct for the outdoor unit, matched indoor coil and 15 feet of refrigerant tubing. For tubing lengths other than 15 feet, add or subtract the amount of refrigerant, using the difference in length multiplied by the per foot value.

All dimensions are in inches. They are subject to change without notice. Certified dimensions will be provided upon request.

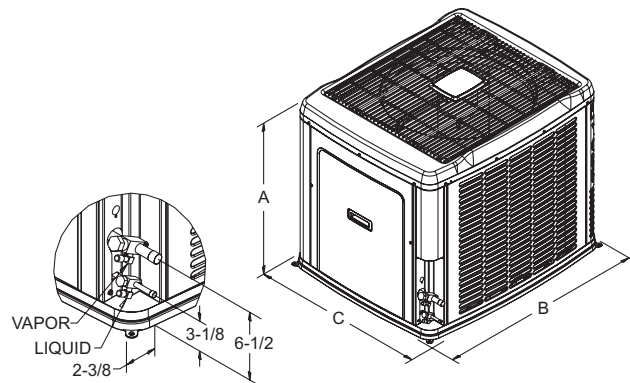
**DIMENSIONS**

Unit Model	Dimensions (Inches)			Refrigerant Connection Line Size	
	A	B	C	Liquid	Vapor
024	29-1/2	37	31	3/8"	3/4"
030	33-1/2	37	31		
036	33-1/2	37	31		7/8"
042	39-1/2	37	31		
048	39-1/2	37	31		
060	39-1/2	37	31		

**Additional R-410A Charge / TXV Size for Various Matched Systems**

Outdoor Unit	CZB02411	CZB03011	CZB03611	CZB04211	CZB04811	CZB06011
Unit Orifice (s)	—	—	—	—	—	—
Factory R-410A Charge, lbs-oz	6-4	7-4	6-15	8-13	8-12	13-9
Indoor Coil <sup>1</sup>	Coil Orifice <sup>2</sup>	TXV Kit <sup>3</sup> - Additional Charge, Oz				
G2FD024(S,H)14,17	61	903 + 3	—	—	—	—
G2FD030(S,H)17	65	903 + 6	903 + 3	—	—	—
G2FD035(S,H)14	65	903 + 6	903 + 3	903 + 0	—	—
G2FD036(S,H)17	75	903 + 12	903 + 7	903 + 3	—	—
G2FD036(S,H)21	75	—	903 + 10	903 + 5	—	—
G2FD042(S,H)21	78	—	903 + 14	903 + 8	904 + 0	—
G2FD046(S,H)17	78	—	903 + 14	903 + 8	904 + 0	905 + 0
G2FD048(S,H)21,24	84	—	—	903 + 16	904 + 6	905 + 8
G2FD060(S,H)24	90	—	—	—	—	905 + 12
G2FD061H24	90	—	—	—	—	905 + 18
G1HA024H14	61	903 + 3	—	—	—	—
G1HA036H14	75	—	—	903 + 5	—	—
G1HA036H17	78	903 + 18	903 + 14	903 + 8	—	—
G1HA048H21	84	—	—	—	904 + 6	905 + 5
G1HA060H24	90	—	—	—	—	906 + 5
G1HD024	59	903 + 4	—	—	—	—
G1HD036	69	—	903 + 10	903 + 6	—	—
G1HD048	81	—	—	—	904 + 2	905 + 4
G1HD060	93	—	—	—	—	906 + 0
G1FA/G1UA024S14,17	59	903 + 0	—	—	—	—
G1FA/G1UA030S14	65	903 + 3	903 + 0	—	—	—
G1FA/G1UA036S14	73	903 + 9	903 + 5	903 + 2	—	—
G1FA/G1UA036S17,21	73	903 + 6	903 + 3	903 + 0	—	—
G1FA/G1UA048S17	84	—	903 + 14	903 + 8	904 + 0	905 + 0
G1FA/G1UA048S21	84	—	903 + 22	903 + 13	904 + 3	905 + 5
G1FA/G1UA060S21,24	90	—	—	—	904 + 10	905 + 12
F2RP024	61	903 + 3	—	—	—	—
F2RP030	65	903 + 6	903 + 3	—	—	—
F2RP036	75	—	903 + 10	903 + 5	—	—
F2RP042	78	—	—	903 + 8	904 + 0	—
F2FP048	84	—	—	903 + 16	904 + 6	905 + 8
F2FP060	90	—	—	—	—	905 + 12
F2FV060	90	—	—	—	—	905 + 12

**FOOTNOTES:**

- 1 Systems matched with furnace or air handlers not equipped with blower-off delays may require blower Time Delay Kit #6918A5011.
- 2 These orifices are factory mounted in the flow device of each indoor coil.
- 3 A TXV kit must be used with these coils to obtain system performance (903, 904, 905, 906 indicates 1TV09...series).

**PROCEDURES:**

1. Unit factory charge listed on the unit nameplate includes refrigerant for the condenser, the smallest evaporator and 15 feet of interconnecting line tubing.
2. Verify the TXV and additional charge required for specific evaporator coil in the system using the above table.
3. Additional charge for the amount of interconnecting line tubing greater than 15 feet at the rate specified on the previous page.
4. Permanently mark the unit nameplate with the total system charge. Total System Charge = Base Charge (as shipped) + adder for evaporator + adder for line set.

**COOLING CAPACITY - With Air Handler Coils**

UNIT MODEL	AIR HANDLER			COIL <sup>1</sup> MODEL	COOLING				
	MODEL	ELECTRIC <sup>2</sup> HEAT KW	W		RATED CFM	TOTAL CAPACITY	SENSIBLE CAPACITY	SEER + TXV <sup>3</sup>	EER
<b>1 PH 13 SEER AC WITH N-AH / G2FD</b>									
CZB02411	N1AHB08	2,5,8,10	17	G2FD024(S,H)17	800	22.6	16.5	12.75	11.05
	N1AHB08	5,8,10,15,19	17	G2FD030(S,H)17	800	23.0	16.8	13.00	11.20
CZB03011	N1AHB12	5,8,10,15,19	17	G2FD030(S,H)17	1000	29.4	21.5	13.00	11.35
	N1AHB12	5,8,10,15,19	17	G2FD036(S,H)17	1000	30.2	22.1	13.00	11.35
CZB03611	N1AHB12	5,8,10,15,19	17	G2FD036(S,H)17	1200	35.6	26.3	13.00	11.20
	N1AHB12	5,8,10,15,19	17	G2FD046(S,H)17	1200	36.0	26.7	13.00	11.50
CZB04211	N1AHC16	5,8,10,15,20	21	G2FD042(S,H)21	1400	40.0	29.0	12.75	11.00
	N1AHC16	5,8,10,15,20	21	G2FD048(S,H)21	1400	41.0	30.2	13.00	11.30
CZB04811	N1AHC16	5,8,10,15,20	21	G2FD048(S,H)21	1600	48.0	35.8	12.50	11.20
	N1AHD20	8,10,15,20,25,30	24	G2FD060(S,H)24	1600	48.5	36.5	13.00	11.45
	N1AHD20	8,10,15,20,25,30	24	G2FD061H24	1600	49.0	36.9	13.00	11.50
CZB06011	N1AHD20	8,10,15,20,25,30	24	G2FD060(S,H)24	1800	57.0	40.8	13.00	11.20
	N1AHD20	8,10,15,20,25,30	24	G2FD061H24	1800	57.5	41.4	13.00	11.30
<b>1 PH 13 SEER AC / N1VS - VARIABLE SPEED</b>									
CZB02411	N1VSB12	5,8,10,15,19	17	G2FD024(S,H)17	825	23.2	16.9	14.00	12.20
	N1VSB12	5,8,10,15,19	17	G2FD036(S,H)17	825	24.0	17.8	14.00	12.70
CZB03011	N1VSB12	5,8,10,15,19	17	G2FD036(S,H)17	1000	30.6	22.3	14.00	12.60
	N1VSB12	5,8,10,15,19	17	G2FD046(S,H)17	1000	31.4	22.7	14.00	12.95
CZB03611	N1VSB12	5,8,10,15,19	17	G2FD036(S,H)17	1200	36.0	26.5	13.50	11.80
	N1VSB12	5,8,10,15,19	17	G2FD046(S,H)17	1200	36.2	27.2	13.80	12.25
	N1VSC16	5,8,10,15,20	21	G2FD048(S,H)21	1200	37.0	28.3	14.00	12.90
CZB04211	N1VSC16	5,8,10,15,20	21	G2FD048(S,H)21	1380	41.5	30.2	13.50	12.10
CZB04811	N1VSC16	5,8,10,15,20	21	G2FD048(S,H)21	1590	48.0	35.1	13.25	11.70
	N1VSD20	8,10,15,20,25,30	24	G2FD060(S,H)24	1600	48.5	35.8	13.25	11.90
	N1VSD20	8,10,15,20,25,30	24	G2FD061H24	1600	49.0	36.3	13.25	12.05
CZB06011	N1VSD20	8,10,15,20,25,30	24	G2FD060(S,H)24	1780	57.0	39.6	13.10	11.40
	N1VSD20	8,10,15,20,25,30	24	G2FD061H24	1780	57.5	40.2	13.25	11.55
<b>1 PH 13 SEER AC / F2RP / RC / FP / FC / FV<sup>4,5</sup></b>									
CZB02411	F2RP024	5,8,10	18	--	800	22.6	16.5	12.50	11.05
	F2RP030	5,8,10,15	18	--	800	23.0	16.8	13.00	11.20
CZB03011	F2RP030	5,8,10,15	18	--	1000	29.6	21.5	13.00	11.35
	F2RP036	5,8,10,15	21	--	1000	30.6	22.2	13.00	11.70
CZB03611	F2RP036	5,8,10,15	21	--	1200	36.2	26.7	13.00	11.40
	F2RP042	5,8,10,15	24	--	1200	36.4	26.9	13.00	11.45
	F2RP048	5,8,10,15	24	--	1200	37.0	28.1	13.00	11.80
CZB04211	F2FP042	5,8,10,15	21	--	1400	40.0	29.0	13.00	11.00
	F2FP048	10,15,20,25	24	--	1400	41.0	30.2	13.00	11.30
CZB04811	F2FP048	10,15,20,25	24	--	1565	47.5	35.8	12.50	11.10
	F2FP060	10,15,20,25	24	--	1600	48.5	36.5	12.75	11.30
	F2FV060	10,15,20,25	24	--	1600	49.0	36.7	13.25	11.95
CZB06011	F2FP060	10,15,20,25	24	--	1800	56.5	39.3	12.50	10.90
	F2FV060	10,15,20,25	24	--	1780	57.0	39.7	13.25	11.45

Rated in accordance with DOE test procedures (Federal Register 12-27-79 and 3-18-88) and ARI Standards 210.

Cooling MBH based on 80°F entering air temperature, 50% RH, and rated air flow.

EER (Energy Efficiency Ratio) is the total cooling output in BTU's at 95°F outdoor ambient divided by the total electric power in watt-hours at those conditions.

SEER (Seasonal Energy Efficiency Ratio) is the total cooling output in BTU's during a normal annual usage period for cooling divided by the total electric power input in watt-hours during the same period.

1 G2FD coils available with a factory installed horizontal drain pan. See price pages for specific model number.

2 Single phase units require single phase 2HK heaters.

3 TXV = Use 1TV900 series kit.

4 To meet R=4.2 insulation requirements, substitute F2FP for F2RP. All ratings remain the same.

5 FG8, FG9, and FL8 furnaces and F2RP air handlers have B.O.D. standard.

\*\* Refer to Quick Selection Chart for specific furnace match-up.

**COOLING CAPACITY - Upflow, Downflow & Horizontal Furnaces and Coils**

UNIT MODEL	FURNACE**		COIL MODEL	COOLING				
	CFM RANGE (MIN.-MAX.)	W		RATED CFM	TOTAL CAPACITY	SENSIBLE CAPACITY	SEER <sup>1,2</sup>	EER
CZB02411	700 900	14,17	G1FA024S14,17	800	22.2	16.0	12.50	10.85
		14	G1FA030S14	800	22.6	16.5	12.75	11.05
		14	G1FA036S14	800	23.2	17.0	13.00	11.25
		17,21	G1FA036S17,21	800	23.0	16.8	13.00	11.20
		14,17	G2FD024(S,H)14,17	800	22.6	16.5	12.75	11.05
		17	G2FD030(S,H)17	800	23.0	16.8	13.00	11.20
		14	G2FD035(S,H)14	800	23.0	16.8	13.00	11.20
		17	G2FD036(S,H)17	800	23.4	17.3	13.00	11.35
		-	G1HA024H14	760	22.6	16.1	12.75	11.05
		-	G1HA036H17	760	22.6	16.8	12.75	11.05
		-	G1HD024	800	22.6	16.7	12.75	11.10
		14,17	G1UA024S14,17	800	22.2	16.0	12.50	10.85
		14	G1UA030S14	800	22.6	16.5	12.75	11.05
		14	G1UA036S14	800	23.2	17.0	13.00	11.25
17,21	G1UA036S17,21	800	23.0	16.8	13.00	11.20		
CZB03011	800 1200	14	G1FA036S14	1000	29.8	21.8	13.00	11.50
		17,21	G1FA036S17,21	1000	29.4	21.5	13.00	11.35
		17	G1FA048S17	1000	30.2	22.5	13.50	11.80
		21,24	G1FA048S21	1000	30.2	23.0	13.50	11.95
		17	G2FD030(S,H)17	1000	29.4	21.5	13.00	11.35
		14	G2FD035(S,H)14	1000	29.4	21.5	13.00	11.35
		17	G2FD036(S,H)17	1000	30.2	22.1	13.00	11.60
		21	G2FD036(S,H)21	1000	30.4	22.2	13.00	11.70
		21	G2FD042(S,H)21	1000	30.8	22.4	13.00	11.80
		17	G2FD046(S,H)17	1000	30.2	22.5	13.50	11.80
		-	G1HA036H17	950	30.4	21.9	13.00	11.80
		-	G1HD036	1000	30.4	22.4	13.00	11.65
		14	G1UA030S14	1000	29.0	21.0	13.00	11.15
		14	G1UA036S14	1000	29.8	21.8	13.00	11.50
17,21	G1UA036S17,21	1000	29.4	21.5	13.00	11.35		
17	G1UA048S17	1000	30.2	22.5	13.50	11.80		
21,24	G1UA048S21	1000	30.2	23.0	13.50	11.95		
CZB03611	1000 1400	14	G1FA036S14	1200	35.0	25.8	12.50	11.05
		17,21	G1FA036S17,21	1200	34.6	25.4	12.50	10.95
		17	G1FA048S17	1200	36.0	27.0	13.00	11.50
		21,24	G1FA048S21	1200	36.2	27.5	13.00	11.70
		14	G2FD035(S,H)14	1200	34.6	25.4	12.50	10.95
		17	G2FD036(S,H)17	1200	35.6	26.3	13.00	11.20
		21	G2FD036(S,H)21	1200	36.2	26.7	13.00	11.40
		21	G2FD042(S,H)21	1200	36.4	26.9	13.00	11.45
		17	G2FD046(S,H)17	1200	36.0	27.0	13.00	11.50
		21,24	G2FD048(S,H)21,24	1200	36.2	28.1	13.00	11.80
		-	G1HA036H14	1140	35.8	26.1	13.00	11.40
		-	G1HA036H17	1140	36.2	26.3	13.00	11.50
		-	G1HD036	1200	35.8	26.6	13.00	11.30
		14	G1UA036S14	1200	35.0	25.8	12.50	11.05
17,21	G1UA036S17,21	1200	34.6	25.4	12.50	10.95		
17	G1UA048S17	1200	36.0	27.0	13.00	11.50		
21,24	G1UA048S21	1200	36.2	27.5	13.00	11.70		
CZB04211	1200 1600	17	G1FA048S17	1400	40.0	29.2	12.75	11.05
		21,24	G1FA048S21	1400	40.5	29.6	12.75	11.15
		21,24	G1FA060S21,24	1400	41.5	30.6	13.00	11.45
		21	G2FD042(S,H)21	1400	40.0	29.0	12.75	11.00
		17	G2FD046(S,H)17	1400	40.0	29.2	12.75	11.05
		21,24	G2FD048(S,H)21,24	1400	41.0	30.2	13.00	11.30
		-	G1HA048S21	1330	40.5	29.0	12.75	11.20
		-	G1HD048	1400	40.0	29.2	12.50	11.06
		17	G1UA048S17	1400	40.0	29.2	12.75	11.05
		21,24	G1UA048S21	1400	40.5	29.6	12.75	11.15
21,24	G1UA060S21,24	1400	41.5	30.6	13.00	11.45		

See Page 6 for Notes

**COOLING CAPACITY - Upflow, Downflow & Horizontal Furnaces and Coils (Continued)**

UNIT MODEL	FURNACE**		COIL MODEL	COOLING				
	CFM RANGE (MIN.-MAX.)	W		RATED CFM	TOTAL CAPACITY	SENSIBLE CAPACITY	SEER <sup>1,2</sup>	EER
CZB04811	1400 1800	17	G1FA048S17	1600	46.5	34.6	12.50	10.95
		21,24	G1FA048S21	1600	47.0	35.0	12.50	11.10
		21,24	G1FA060S21,24	1600	48.5	36.5	13.00	11.45
		17	G2FD046(S,H)17	1600	46.5	34.6	12.50	10.95
		21,24	G2FD048(S,H)21,24	1600	48.0	35.8	12.50	11.20
		24	G2FD060(S,H)24	1600	48.5	36.5	13.00	11.45
		24	G2FD061H24	1600	49.0	36.9	13.00	11.50
		-	G1HA048S21	1520	47.0	34.2	12.50	11.10
		-	G1HD048	1600	47.0	35.2	12.50	11.10
		17	G1UA048S17	1600	46.5	34.6	12.50	10.95
		21,24	G1UA048S21	1600	47.0	35.0	12.50	11.10
		21,24	G1UA060S21,24	1600	48.5	36.5	13.00	11.45
CZB06011	1600 2000	21,24	G1FA060S21,24	1800	57.0	40.8	13.00	11.20
		24	G2FD060(S,H)24	1800	57.0	40.8	13.00	11.20
		24	G2FD061H24	1800	57.5	41.4	13.00	11.30
		-	G1HA060H24	1800	56.5	39.9	13.00	11.25
		-	G1HD060	1800	56.0	39.7	12.50	11.05
		21,24	G1UA060S21,24	1800	57.0	40.8	13.00	11.20

1 Requires a 2FD Blower Time Delay unless a standard furnace is equipped with one.

2 TXV = Use 1TV900 series kit.

\*\* Refer to Quick Selection Chart for specific furnace match-up.

**ACCESSORIES\***

**Hard Start Kit (024-31994-000, 024-31995-000)** - Provides increased starting torque for areas with low voltage.

**TXV Kits** - 1TV09 series thermal expansion valves precisely meter refrigerant for optimum performance

**Low Ambient Pressure Switch Kit (2LA06700424)**- Allows use of air conditioning at low outdoor ambient temperatures. For use with models containing R-410A refrigerant only.

**Dehumidistat (2HU16700124)** - Provides increased dehumidification when matched with variable speed furnace or air handler.

**Room Thermostats** - A wide selection of compatible thermostats are available to provide optimum performance and features for any installation.

1 Heat Stage only, manual, mechanical thermostat. Add sub-base for 1H/1C.

1H/1C, manual change-over electronic non-programmable thermostat.

1H/1C, auto/manual changeover, electronic programmable, deluxe 7-day, thermostat.

1H/1C, auto/manual changeover, electronic programmable.

\* For the most current accessory information, refer to the price book or consult factory.

**SOUND RATINGS\***

UNIT MODEL	SOUND RATINGS (dba)
024	69
030	69
036	72
042	72
048	72
060	72

\* Rated in accordance with ARI 270-95 Standards.

## COOLING CAPACITY - With Variable Speed Furnaces

UNIT MODEL	VARIABLE SPEED FURNACE MODEL	COIL MODEL <sup>1</sup>	W	COOLING				
				RATED CFM	TOTAL CAPACITY	SENSIBLE CAPACITY	SEER + TXV <sup>2</sup>	EER
<b>1 PH 13 SEER AC / P*DU / P1XD / P1XU - VARIABLE SPEED<sup>3</sup></b>								
CZB02411	P*DUA12V	G1FA024S14	14	875	22.8	16.7	13.50	11.70
	P1XUB12V	G1FA024S17	17	800	22.6	16.1	14.00	11.80
	P1XDB12V	G1HA036H17	17	815	23.0	17.6	13.50	12.00
	P*DUA12V	G2FD024(S,H)14	14	875	23.2	17.3	14.00	11.95
	P1XUB12V	G2FD024(S,H)17	17	815	23.0	16.7	14.00	12.00
CZB03011	P1XDB12V	G2FD024(S,H)17	17	800	23.0	16.8	14.00	12.05
	P*DUA12V	G1FA030S14	14	1080	29.4	21.9	13.25	11.70
	P*DUB16V	G1FA036S17	17	1050	30.2	22.2	14.00	12.40
	P1XUB12V	G1FA036S17	17	1020	30.0	21.9	13.50	12.10
	P1XUC16V	G1FA036S21	21	1000	30.0	21.7	14.00	12.40
	P1XDB12V	G1HA036H17	17	1080	31.0	23.2	14.00	12.30
	P*DUB16V	G2FD030(S,H)17	17	1050	30.2	22.2	14.00	12.40
	P1XDB12V	G2FD030(S,H)17	17	1050	30.2	23.0	13.50	12.30
	P1XUB12V	G2FD030(S,H)17	17	1020	30.0	21.9	13.50	12.10
	P*DUA12V	G2FD035(S,H)14	14	1080	29.8	21.6	13.50	11.80
CZB03611	P1XDC20V	G2FD036(S,H)21	21	1080	31.0	23.2	14.00	12.30
	P1XUC16V	G2FD036(S,H)21	21	1000	30.6	22.5	14.00	12.60
	P*DUA12V	G1FA036S14	14	1120	35.2	25.8	13.10	11.40
	P*DUB16V	G1FA036S17	17	1200	35.0	25.6	13.25	11.60
	P1XUB12V	G1FA036S17	17	1130	34.8	25.7	13.10	11.25
	P1XUC16V	G1FA036S21	21	1200	35.0	25.6	13.50	11.60
	P1XDB12V	G1HA036H17	17	1130	36.2	20.4	13.25	11.60
	P*DUA12V	G2FD035(S,H)14	14	1120	34.8	25.3	13.10	11.25
	P*DUB16V	G2FD036(S,H)17	17	1200	36.0	26.5	13.50	11.90
	P1XDB12V	G2FD036(S,H)17	17	1130	35.6	25.8	13.25	11.60
	P1XUB12V	G2FD036(S,H)17	17	1020	35.8	26.4	13.25	11.55
	P1XUC16V	G2FD036(S,H)21	21	1160	36.6	26.9	13.75	12.10
	P1XUC20V	G2FD036(S,H)21	21	1130	36.4	26.9	13.50	11.90
CZB04211	P*DUB16V	G2FD046(S,H)17	17	1200	37.0	27.2	13.50	12.30
	P1XUB12V	G2FD046(S,H)17	17	1100	36.8	27.1	13.50	11.95
	P1XUC20V	G2FD048(S,H)21	21	1130	38.0	28.2	13.50	12.35
	P*DUB16V	G1FA048S17	17	1400	40.5	29.3	13.00	11.50
	P*DUC20V	G1FA048S21	21	1400	41.0	29.9	13.25	11.70
	P1XUC16V	G1FA048S21	21	1400	41.0	29.8	13.25	11.70
	P1XUC20V	G1FA048S21	21	1410	41.0	29.9	13.00	11.65
	P1XUD20V	G1FA060S24	24	1430	42.0	31.0	13.25	11.85
	P1XDC20V	G1HA048H21	21	1410	40.5	29.8	13.00	11.35
	P*DUC20V	G2FD042(S,H)21	21	1400	40.5	29.1	13.00	11.50
	P1XUC16V	G2FD042(S,H)21	21	1400	40.0	29.1	12.80	11.40
	P1XUC20V	G2FD042(S,H)21	21	1410	40.0	29.2	12.80	11.35
CZB04811	P1XDC20V	G2FD042(S,H)21	21	1410	40.0	29.1	12.50	11.10
	P1XDC20V	G2FD048(S,H)21	21	1410	41.0	30.4	13.05	11.45
	P1XDD20V	G2FD048(S,H)24	24	1365	41.5	30.0	13.25	11.90
	P1XUD20V	G2FD048(S,H)24	24	1430	41.5	30.6	13.10	11.65
	P*DUB16V	G1FA048S17	17	1500	46.5	33.7	12.60	11.10
	P*DUC20V	G1FA048S21	21	1610	47.5	35.2	12.75	11.25
	P1XUC16V	G1FA048S21	21	1480	47.0	33.8	12.75	11.20
	P1XUC20V	G1FA048S21	21	1590	47.0	35.0	12.75	11.20
	P1XUD20V	G1FA060S24	24	1620	49.0	36.8	13.25	11.60
	P1XDC20V	G1HA048H21	21	1450	47.0	33.6	13.00	11.30
CZB06011	P*DUC20V	G2FD048(S,H)21	21	1610	48.0	36.0	13.00	11.45
	P1XUC16V	G2FD048(S,H)21	21	1480	47.5	34.6	13.00	11.35
	P1XUC20V	G2FD048(S,H)21	21	1590	48.0	35.8	12.75	11.35
	P1XUD20V	G2FD048(S,H)24	24	1620	48.0	36.1	12.75	11.35
	P1XDC20V	G2FD060(S,H)24	24	1450	47.5	34.3	13.00	11.45
	P1XDC20V	G2FD060(S,H)24	24	1610	48.5	36.7	13.05	11.55
	P1XUD20V	G2FD060(S,H)24	24	1620	49.0	36.8	13.25	11.60
	P*DUC20V	G1FA060S21	21	1730	57.0	40.2	13.10	11.30
	P1XUC20V	G1FA060S21	21	1800	57.0	40.8	13.05	11.20
	P1XUD20V	G1FA060S24	24	1620	56.5	39.0	13.10	11.40
	P1XDD20V	G1HA060H24	24	1610	56.5	38.9	13.10	11.35
	P1XDC20V	G2FD060(S,H)24	24	1610	56.5	38.9	13.05	11.35
CZB06011	P1XDD20V	G2FD060(S,H)24	24	1610	56.5	38.9	13.10	11.35
	P1XUD20V	G2FD060(S,H)24	24	1620	56.5	39.0	13.10	11.40
	P1XDC20V	G2FD061H24	24	1610	57.0	38.9	13.10	11.35
	P1XUD20V	G2FD061H24	24	1620	57.0	39.4	13.25	11.55

1 G2FD coils available with a factory installed horizontal drain pan. See price pages for specific model number.

2 TXV = Use 1TV900 Series Kit.

3 Variable speed furnaces have B.O.D (Blower on Delay) standard.

<b>COOLING PERFORMANCE DATA</b>																
<b>OUTDOOR UNIT MODEL NO.</b>		<b>CZB02411</b>														
<b>INDOOR COIL MODEL NO.</b>		<b>G2FD030S17</b>														
<b>CONDENSER ENTERING AIR TEMPERATURE</b>	ID CFM	600					800					1000				
	ID DB (°F)	80	80	75	80	80	80	80	75	80	80	80	80	75	80	80
	ID WB (°F)	57	62	62	67	72	57	62	62	67	72	57	62	62	67	72
65	T.C.	19.1	19.3	21.9	22.9	26.0	21.4	21.1	22.0	23.7	26.3	23.7	25.6	22.2	24.5	26.6
	S.C.	19.1	16.5	16.1	15.8	12.0	21.4	21.1	18.3	18.5	13.5	23.7	25.6	20.5	21.2	15.0
	K.W.	1.6	1.6	1.5	1.6	1.6	1.6	1.6	1.6	1.6	1.6	1.6	1.6	1.6	1.6	1.6
75	T.C.	21.4	22.2	20.6	24.7	27.3	23.0	23.4	22.4	25.7	28.4	24.6	24.6	24.1	26.6	29.4
	S.C.	21.3	18.4	15.0	15.6	12.5	23.0	21.5	17.5	17.8	13.9	24.6	24.6	20.0	20.1	15.4
	K.W.	1.4	1.4	1.4	1.3	1.3	1.4	1.4	1.4	1.3	1.4	1.3	1.3	1.3	1.3	1.4
85	T.C.	20.2	20.7	21.2	23.8	26.7	22.2	22.9	22.2	24.7	27.3	24.1	25.1	23.2	25.5	28.0
	S.C.	20.2	17.5	15.5	15.7	12.2	22.2	21.3	17.9	18.2	13.7	24.1	25.1	20.2	20.6	15.2
	K.W.	1.5	1.5	1.5	1.5	1.5	1.5	1.5	1.5	1.5	1.5	1.5	1.5	1.5	1.5	1.5
95	T.C.	18.8	19.5	19.6	22.0	24.9	20.6	21.3	20.5	23.0	25.5	22.5	23.2	21.4	23.7	26.2
	S.C.	18.8	16.7	14.4	14.6	11.6	20.6	19.9	16.6	16.8	13.0	22.5	23.2	18.8	19.3	14.4
	K.W.	1.8	1.8	1.8	1.8	1.8	1.8	1.8	1.8	1.8	1.8	1.8	1.8	1.8	1.8	1.8
105	T.C.	17.4	18.2	17.9	20.3	23.0	19.1	19.7	18.8	21.1	23.7	20.8	21.2	19.6	21.8	24.4
	S.C.	17.4	15.9	13.3	13.6	11.0	19.1	18.6	15.4	15.7	12.3	20.8	21.2	17.4	17.9	13.7
	K.W.	2.1	2.1	2.1	2.1	2.1	2.1	2.1	2.1	2.1	2.0	2.0	2.0	2.1	2.0	2.0
115	T.C.	16.0	17.1	16.3	18.6	21.2	17.6	18.2	17.1	19.3	21.9	19.2	19.4	17.8	20.1	22.6
	S.C.	16.0	15.1	12.2	12.5	10.4	17.6	17.2	14.1	14.6	11.7	19.2	19.4	16.1	16.6	13.0
	K.W.	2.4	2.4	2.3	2.4	2.3	2.3	2.3	2.3	2.3	2.3	2.3	2.3	2.3	2.3	2.3
125	T.C.	14.6	15.8	14.7	16.9	19.5	16.1	16.6	15.4	17.6	20.2	17.6	17.5	16.1	18.3	20.8
	S.C.	14.6	14.3	11.1	11.5	9.8	16.1	15.9	12.9	13.4	11.0	17.6	17.5	14.7	15.3	12.2
	K.W.	2.6	2.6	2.6	2.6	2.6	2.6	2.6	2.6	2.6	2.6	2.6	2.6	2.6	2.6	2.6

NOTE: ALL CAPACITIES ARE NET (KBTUH) WITH INDOOR FAN HEAT ALREADY DEDUCTED AT 1250 BTUH/1000 CFM.

### Multipliers for determining the performance with other indoor sections.

NOTE: For dry bulb temperatures different than those listed (between 73-87 F), sensible capacity increases by 1060 BTUH per 1000 CFM per degree above the listed temperature and decreases by 1060 BTUH per 1000 CFM per degree below the listed temperature.

Air Handler	Coil	T.C.	S.C.	KW
N1AHB08	G2FD024(S,H)17	0.98	0.98	1.00
N1AHB08	G2FD030(S,H)17	1.00	1.00	1.00
N1VSB12	G2FD024(S,H)17	1.01	1.00	0.93
N1VSB12	G2FD036(S,H)17	1.04	1.06	0.92
F2RP024		0.98	0.98	1.00
F2RP030		1.00	1.00	1.00
	G1FA024S14,17	0.97	0.95	1.00
	G1FA030S14	0.98	0.98	1.00
	G1FA036S14	1.01	1.01	1.00
	G1FA036S17,21	1.00	1.00	1.00
	G2FD024(S,H)14,17	0.98	0.98	1.00
	G2FD035(S,H)14	1.00	1.00	1.00
	G2FD036(S,H)17	1.02	1.03	1.00
	G1HA024H14	0.98	0.96	1.00
	G1HA036H17	0.98	1.00	1.00
	G1HD024	0.98	0.99	0.99
	G1UA024S14,17	0.97	0.95	1.00
	G1UA030S14	0.98	0.98	1.00
	G1UA036S14	1.01	1.01	1.00
	G1UA036S17,21	1.00	1.00	1.00

Variable Speed Furnace	Coil	T.C.	S.C.	KW
P1XDB12V	G2FD024(S,H)17	1.00	1.00	0.93
P1XDB12V	G1HA036H17	1.00	1.05	0.93
P*DUA12V	G1FA024S14	0.99	1.00	0.95
P*DUA12V	G2FD024(S,H)14	1.01	1.03	0.95
P1XUB12V	G1FA024S17	0.98	0.96	0.93
P1XUB12V	G2FD024(S,H)17	1.00	1.00	0.93

<b>COOLING PERFORMANCE DATA</b>																
<b>OUTDOOR UNIT MODEL NO.</b>		<b>CZB03011</b>														
<b>INDOOR COIL MODEL NO.</b>		<b>G2FD030S17</b>														
<b>CONDENSER ENTERING AIR TEMPERATURE</b>	<b>ID CFM</b>	800					1000					1200				
		<b>ID DB (°F)</b>		80	80	75	80	80	80	80	80	80	80	80	80	80
		<b>ID WB (°F)</b>		57	62	62	67	72	57	62	62	67	72	57	62	62
65	T.C.	21.7	22.2	24.8	29.7	33.6	24.1	24.3	25.9	29.4	33.3	26.5	26.4	27.0	29.0	33.1
	S.C.	21.3	17.8	16.8	19.5	15.9	23.7	22.0	19.2	20.8	16.7	26.1	26.3	21.6	22.1	17.5
	K.W.	2.1	4.6	2.1	2.1	2.2	2.1	3.3	2.1	2.1	2.2	2.0	2.0	2.1	2.1	2.2
75	T.C.	24.9	27.5	28.0	30.4	34.2	27.0	28.7	28.8	31.4	35.4	29.2	30.0	29.7	32.4	36.5
	S.C.	24.6	22.6	19.5	19.0	15.7	26.7	24.8	21.4	21.0	17.1	28.9	26.9	23.3	22.9	18.5
	K.W.	1.8	1.8	1.8	1.8	1.9	1.8	1.8	1.8	1.8	1.9	1.8	1.8	1.8	1.8	1.9
85	T.C.	23.3	30.6	26.4	30.1	33.9	25.6	29.4	27.4	30.4	34.4	27.9	28.2	28.4	30.7	34.8
	S.C.	22.9	20.2	18.1	19.3	15.8	25.2	23.4	20.3	20.9	16.9	27.5	26.6	22.4	22.5	18.0
	K.W.	1.9	3.2	1.9	2.0	2.0	1.9	2.6	1.9	2.0	2.0	1.9	1.9	1.9	2.0	2.0
95	T.C.	22.5	20.7	24.9	27.6	31.2	24.5	23.7	25.8	29.4	31.9	26.6	26.7	26.7	29.1	32.5
	S.C.	22.2	20.5	17.8	18.0	14.6	24.2	23.1	19.8	21.5	16.0	26.3	25.8	21.8	21.6	17.3
	K.W.	2.2	3.2	2.2	2.3	2.4	2.2	2.7	2.3	2.3	2.4	2.2	2.3	2.3	2.3	2.4
105	T.C.	21.6	10.8	23.5	25.1	28.4	23.5	22.9	24.3	26.3	29.4	25.4	25.2	25.1	27.5	30.3
	S.C.	21.4	20.8	17.5	16.8	13.4	23.2	22.9	19.4	18.8	15.1	25.1	24.9	21.2	20.8	16.7
	K.W.	2.6	3.2	2.6	2.6	2.7	2.6	2.9	2.6	2.7	2.7	2.6	2.6	2.6	2.7	2.7
115	T.C.	20.8	21.1	22.1	22.7	25.7	22.5	22.6	22.8	24.4	26.9	24.2	23.8	23.5	26.0	28.1
	S.C.	20.6	21.1	17.2	15.6	12.3	22.3	22.6	18.9	17.8	14.2	23.9	24.1	20.6	19.9	16.0
	K.W.	2.9	3.2	2.9	3.0	3.0	2.9	3.1	2.9	3.0	3.0	2.9	2.9	2.9	3.0	3.0
125	T.C.	20.0	21.4	20.6	20.4	23.1	21.5	22.4	21.3	22.4	24.5	23.0	22.4	21.9	24.5	26.0
	S.C.	19.9	21.4	16.9	14.4	11.1	21.3	22.4	18.5	16.7	13.2	22.8	23.3	20.0	19.1	15.4
	K.W.	3.2	3.2	3.2	3.3	3.3	3.2	3.2	3.2	3.3	3.3	3.3	3.2	3.2	3.3	3.4

NOTE: ALL CAPACITIES ARE NET (KBTUH) WITH INDOOR FAN HEAT ALREADY DEDUCTED AT 1250 BTUH/1000 CFM.

### Multipliers for determining the performance with other indoor sections.

NOTE: For dry bulb temperatures different than those listed (between 73-87 F), sensible capacity increases by 1060 BTUH per 1000 CFM per degree above the listed temperature and decreases by 1060 BTUH per 1000 CFM per degree below the listed temperature.

<b>Air Handler</b>	<b>Coil</b>	<b>T.C.</b>	<b>S.C.</b>	<b>KW</b>
N1AHB12	G2FD030(S,H)17	1.00	1.00	1.00
N1AHB12	G2FD036(S,H)17	1.03	1.03	1.03
N1VSB12	G2FD036(S,H)17	1.04	1.04	0.94
N1VSB12	G2FD046(S,H)17	1.07	1.06	0.94
F2RP030		1.01	1.00	1.01
F2RP036		1.04	1.03	1.01
	G1FA030S14	0.99	0.98	1.00
	G1FA036S14	1.01	1.02	1.00
	G1FA036S17,21	1.00	1.00	1.00
	G1FA048S17	1.03	1.04	0.99
	G1FA048S21	1.03	1.07	0.98
	G2FD035(S,H)14	1.00	1.00	1.00
	G2FD036(S,H)17	1.03	1.03	1.01
	G2FD036(S,H)21	1.03	1.03	1.00
	G2FD042(S,H)21	1.05	1.04	1.01
	G2FD046(S,H)17	1.03	1.04	0.99
	G1HA036H17	1.03	1.02	0.99
	G1HD036	1.03	1.04	1.01
	G1UA030S14	0.99	0.98	1.00
	G1UA036S14	1.01	1.02	1.00
	G1UA036S17,21	1.00	1.00	1.00
	G1UA048S17	1.03	1.04	0.99
	G1UA048S21,24	1.03	1.07	0.98

<b>Variable Speed Furnace</b>	<b>Coil</b>	<b>T.C.</b>	<b>S.C.</b>	<b>KW</b>
P1XDB12V	G2FD030(S,H)17	1.02	1.03	0.97
P1XDB12V	G1HA036H17	1.03	1.07	0.95
P1XDC20V	G2FD036(S,H)21	1.05	1.08	0.97
P*DUA12V	G1FA030S14	1.00	1.02	0.97
P*DUA12V	G2FD035(S,H)14	1.01	1.01	0.97
P*DUB16V	G1FA036S17	1.03	1.03	0.94
P*DUB16V	G2FD030(S,H)17	1.03	1.03	0.94
P1XUB12V	G1FA036S17	1.02	1.02	0.96
P1XUB12V	G2FD030(S,H)17	1.02	1.02	0.96
P1XUC16V	G1FA036S21	1.02	1.01	0.93
P1XUC16V	G2FD036(S,H)21	1.05	1.05	0.93

<b>COOLING PERFORMANCE DATA</b>																	
<b>OUTDOOR UNIT MODEL NO.</b>		<b>CZB03611</b>															
<b>INDOOR COIL MODEL NO.</b>		<b>G2FD036S17</b>															
<b>CONDENSER ENTERING AIR TEMPERATURE</b>	ID CFM	1050					1200					1350					
	ID DB (°F)	80	80	75	80	80	80	80	75	80	80	80	80	75	80	80	
	ID WB (°F)	57	62	62	67	72	57	62	62	67	72	57	62	62	67	72	
65	T.C.	32.5	33.2	31.6	34.3	38.0	34.2	33.9	31.9	35.3	38.2	35.9	34.7	32.1	36.3	38.4	
	S.C.	29.7	29.7	23.6	23.6	18.6	30.9	31.4	25.4	32.4	20.0	32.0	33.1	27.1	41.2	21.4	
	K.W.	2.5	2.5	2.5	2.6	2.5	2.5	2.5	2.5	2.6	2.5	2.5	2.5	2.5	2.5	2.5	
75	T.C.	35.2	35.9	35.1	38.6	41.4	36.5	37.0	35.7	39.5	41.9	37.8	38.1	36.3	40.3	42.3	
	S.C.	32.6	30.3	25.5	25.5	20.4	34.0	32.4	27.2	20.2	21.4	35.4	34.5	28.9	14.9	22.4	
	K.W.	2.2	2.2	2.2	2.2	2.2	2.2	2.2	2.2	2.2	2.2	2.2	2.2	2.2	2.2	2.2	
85	T.C.	33.8	34.6	33.4	36.5	39.7	35.3	35.5	33.8	37.4	40.0	36.8	36.4	34.2	38.3	40.4	
	S.C.	31.2	30.0	24.5	24.5	19.5	32.4	31.9	26.3	26.3	20.7	33.7	33.8	28.0	28.0	21.9	
	K.W.	2.4	2.4	2.4	2.4	2.4	2.4	2.4	2.4	2.4	2.4	2.4	2.4	2.4	2.4	2.4	
95	T.C.	32.1	32.6	31.4	34.5	37.3	33.5	33.6	31.8	35.6	37.6	34.9	34.5	32.2	36.1	37.9	
	S.C.	29.6	28.7	23.7	23.8	18.8	30.8	30.4	25.3	26.3	19.9	31.9	32.0	26.9	27.2	21.1	
	K.W.	2.8	2.8	2.8	2.8	2.8	2.8	2.8	2.8	2.8	2.8	2.8	2.8	2.8	2.8	2.8	
105	T.C.	30.5	30.7	29.3	32.6	34.8	31.7	31.6	29.7	33.3	35.1	32.9	32.6	30.2	34.0	35.4	
	S.C.	28.0	27.4	22.8	23.0	18.0	29.1	28.8	24.3	24.7	19.2	30.1	30.2	25.8	26.3	20.3	
	K.W.	3.2	3.2	3.2	3.2	3.1	3.2	3.2	3.2	3.2	3.1	3.2	3.2	3.2	3.2	3.2	
115	T.C.	28.8	28.9	27.4	30.8	32.5	29.9	29.8	27.8	31.3	32.7	31.0	30.7	28.2	31.8	33.0	
	S.C.	26.4	26.2	21.9	22.3	17.3	27.4	27.4	23.3	23.9	18.4	28.4	28.5	24.7	25.4	19.5	
	K.W.	3.5	3.6	3.5	3.5	3.5	3.5	3.6	3.5	3.5	3.5	3.5	3.6	3.5	3.5	3.5	
125	T.C.	27.2	27.0	25.4	28.9	30.1	28.1	27.9	25.8	29.3	30.3	29.1	28.9	26.2	29.7	30.6	
	S.C.	24.9	24.9	21.0	21.6	16.6	25.8	25.9	22.3	23.1	17.6	26.7	26.8	23.6	24.5	18.7	
	K.W.	3.9	3.9	3.9	3.9	3.9	3.9	3.9	3.9	3.9	3.9	3.9	3.9	3.9	3.9	3.9	

NOTE: ALL CAPACITIES ARE NET (KBTUH) WITH INDOOR FAN HEAT ALREADY DEDUCTED AT 1250 BTUH/1000 CFM.

**Multipliers for determining the performance with other indoor sections.**

NOTE: For dry bulb temperatures different than those listed (between 73-87 F), sensible capacity increases by 1060 BTUH per 1000 CFM per degree above the listed temperature and decreases by 1060 BTUH per 1000 CFM per degree below the listed temperature.

Air Handler	Coil	T.C.	S.C.	KW
N1AHB12	G2FD036(S,H)17	1.00	1.00	1.00
N1AHB12	G2FD046(S,H)17	1.01	1.02	0.98
F2RP036N		1.02	1.02	1.00
F2RP042N		1.02	1.02	1.00
F2RP048N		1.06	1.07	1.00
	G1FA036S14	0.98	0.98	1.00
	G1FA036S17,21	0.97	0.96	0.99
	G1FA048S17	1.01	1.03	0.98
	G1FA048S21	1.02	1.05	0.97
	G2FD035(S,H)14	0.97	0.96	0.99
	G2FD036(S,H)21	1.02	1.02	1.00
	G2FD042(S,H)21	1.02	1.02	1.00
	G2FD046(S,H)17	1.01	1.03	0.98
	G2FD048(S,H)21,24	1.02	1.07	0.97
	G1HA036H14	1.01	0.99	0.99
	G1HA036H17	1.02	1.00	0.99
	G1HD036	1.01	1.01	1.00
	G1UA036S14	0.98	0.98	1.00
	G1UA036S17,21	0.97	0.96	0.99
	G1UA048S17	1.01	1.03	0.98
	G1UA048S21,24	1.02	1.05	0.97

Variable Speed Furnace	Coil	T.C.	S.C.	KW
P1XDB12V	G2FD036(S,H)17	1.00	0.98	0.97
P1XDB12V	G1HA036H17	1.02	0.77	0.98
P1XUC20V	G2FD036(S,H)21	1.02	1.02	0.96
P1XUC20V	G2FD048(S,H)21	1.07	1.07	0.97
P*DUA12V	G1FA036S14	0.99	0.98	0.97
P*DUA12V	G2FD035(S,H)14	0.98	0.96	0.97
P*DUB16V	G1FA036S17	0.98	0.97	0.95
P*DUB16V	G2FD036(S,H)17	1.01	1.01	0.95
P*DUB16V	G2FD046(S,H)17	1.04	1.03	0.95
P1XUB12V	G1FA036S17	0.98	0.98	0.97
P1XUB12V	G2FD036(S,H)17	1.01	1.00	0.98
P1XUB12V	G2FD046(S,H)17	1.03	1.03	0.97
P1XUC16V	G1FA036S21	0.98	0.97	0.95
P1XUC16V	G2FD036(S,H)21	1.03	1.02	0.95

<b>COOLING PERFORMANCE DATA</b>																
<b>OUTDOOR UNIT MODEL NO.</b>		<b>CZB04211</b>														
<b>INDOOR COIL MODEL NO.</b>		<b>G2FD048S21</b>														
<b>CONDENSER ENTERING AIR TEMPERATURE</b>	ID CFM	1200					1400					1600				
	ID DB (°F)	80	80	75	80	80	80	80	75	80	80	80	80	75	80	80
	ID WB (°F)	57	62	62	67	72	57	62	62	67	72	57	62	62	67	72
65	T.C.	35.3	37.7	36.1	39.7	45.0	37.4	38.2	37.5	41.0	45.9	39.5	38.7	38.9	42.3	46.9
	S.C.	35.2	34.0	28.5	28.0	21.7	37.3	37.0	30.8	30.2	22.9	39.4	40.0	33.2	32.4	24.2
	K.W.	2.8	2.8	2.8	2.8	2.9	2.8	2.8	2.8	2.8	2.9	2.8	2.8	2.8	2.8	2.9
75	T.C.	38.1	39.3	40.1	43.1	48.3	39.9	40.4	41.2	44.4	49.7	41.7	41.5	42.3	45.8	51.0
	S.C.	38.1	34.1	29.5	28.8	22.9	39.9	37.0	31.8	31.0	24.3	41.7	39.9	34.2	33.3	25.7
	K.W.	2.5	2.5	2.5	2.5	2.5	2.5	2.5	2.5	2.5	2.5	2.5	2.5	2.5	2.5	2.5
85	T.C.	36.7	38.5	38.1	41.4	46.6	38.7	39.3	39.3	42.7	47.8	40.6	40.1	40.6	44.1	49.0
	S.C.	36.6	34.1	29.0	28.4	22.3	38.6	37.0	31.3	30.6	23.6	40.6	39.9	33.7	32.9	25.0
	K.W.	2.6	2.7	2.6	2.7	2.7	2.6	2.7	2.6	2.7	2.7	2.6	2.7	2.7	2.7	2.7
95	T.C.	34.8	36.3	35.9	39.1	43.9	36.5	37.2	37.0	41.0	44.9	38.2	38.0	38.1	41.3	45.8
	S.C.	34.7	32.9	28.0	27.3	21.3	36.4	35.5	30.2	30.2	22.7	38.1	38.1	32.4	31.8	24.0
	K.W.	3.1	3.1	3.1	3.1	3.1	3.1	3.1	3.1	3.1	3.1	3.1	3.1	3.1	3.1	3.1
105	T.C.	32.9	34.0	33.8	36.8	41.1	34.3	35.0	34.6	37.7	41.9	35.8	36.0	35.5	38.5	42.7
	S.C.	32.7	31.8	26.9	26.3	20.4	34.2	34.0	29.1	28.5	21.7	35.7	36.3	31.2	30.7	23.1
	K.W.	3.6	3.6	3.5	3.6	3.6	3.6	3.6	3.6	3.6	3.6	3.6	3.6	3.6	3.6	3.6
115	T.C.	31.0	31.9	31.7	34.6	38.4	32.2	33.0	32.4	35.2	39.1	33.5	34.0	33.0	35.8	39.7
	S.C.	30.8	30.7	26.0	25.3	19.5	32.1	32.6	28.0	27.5	20.8	33.3	34.5	30.0	29.6	22.1
	K.W.	4.0	4.0	4.0	4.0	4.0	4.0	4.0	4.0	4.0	4.0	4.0	4.0	4.0	4.0	4.0
125	T.C.	29.1	29.7	29.6	32.3	35.8	30.1	31.2	30.1	32.7	36.2	31.2	32.1	30.6	33.2	36.7
	S.C.	28.9	29.6	25.0	24.3	18.5	29.9	31.2	26.9	26.4	19.9	30.9	32.7	28.9	28.5	21.2
	K.W.	4.4	4.4	4.4	4.5	4.5	4.4	4.4	4.4	4.5	4.5	4.4	4.4	4.4	4.5	4.5

NOTE: ALL CAPACITIES ARE NET (KBTUH) WITH INDOOR FAN HEAT ALREADY DEDUCTED AT 1250 BTUH/1000 CFM.

### Multipliers for determining the performance with other indoor sections.

NOTE: For dry bulb temperatures different than those listed (between 73-87 F), sensible capacity increases by 1060 BTUH per 1000 CFM per degree above the listed temperature and decreases by 1060 BTUH per 1000 CFM per degree below the listed temperature.

Air Handler	Coil	T.C.	S.C.	KW
N1AHC16	G2FD042(S,H)21	0.98	0.96	1.00
N1AHC16	G2FD048(S,H)21	1.00	1.00	1.00
N1VSC16	G2FD048(S,H)21	1.01	1.00	0.95
F2FP042N		0.98	0.96	1.00
F2FP048N		1.00	1.00	1.00
	G1FA048S17	0.98	0.97	1.00
	G1FA048S21	0.99	0.98	1.00
	G1FA060S21,24	1.01	1.01	1.00
	G2FD042(S,H)21	0.98	0.96	1.00
	G2FD046(S,H)17	0.98	0.97	1.00
	G1HA048S21	0.99	0.96	1.00
	G1HD048	0.98	0.97	1.00
	G1UA048S17	0.98	0.97	1.00
	G1UA048S21,24	0.99	0.98	1.00
	G1UA060S21,24	1.01	1.01	1.00

Variable Speed Furnace	Coil	T.C.	S.C.	KW
P1XDC20V	G2FD042(S,H)21	0.98	0.96	0.99
P1XDC20V	G2FD048(S,H)21	1.00	1.01	0.99
P1XDC20V	G1HA048H21	0.99	0.99	0.98
P1XDD20V	G2FD048(S,H)24	1.01	0.99	0.96
P*DUB16V	G1FA048S17	0.99	0.97	0.97
P*DUC20V	G1FA048S21	1.00	0.99	0.97
P*DUC20V	G2FD042(S,H)21	0.99	0.97	0.97
P1XUC16V	G1FA048S21	1.00	0.99	0.97
P1XUC16V	G2FD042(S,H)21	0.98	0.96	0.97
P1XUC20V	G1FA048S21	1.00	0.99	0.97
P1XUC20V	G2FD042(S,H)21	0.98	0.97	0.97
P1XUD20V	G1FA060S24	1.02	1.03	0.98
P1XUD20V	G2FD048(S,H)24	1.01	1.01	0.98

<b>COOLING PERFORMANCE DATA</b>																
<b>OUTDOOR UNIT MODEL NO.</b>		<b>CZB04811</b>														
<b>INDOOR COIL MODEL NO.</b>		<b>G1FA060S24</b>														
<b>CONDENSER ENTERING AIR TEMPERATURE</b>	ID CFM	1400					1600					1800				
	ID DB (°F)	80	80	75	80	80	80	80	75	80	80	80	80	75	80	80
	ID WB (°F)	57	62	62	67	72	57	62	62	67	72	57	62	62	67	72
65	T.C.	41.0	43.5	40.5	45.6	52.5	43.1	44.2	41.1	46.4	52.0	45.2	45.0	41.7	47.2	51.4
	S.C.	38.1	42.1	32.0	33.3	26.4	40.2	43.0	34.3	35.6	27.6	42.3	43.9	36.6	37.9	28.8
	K.W.	3.4	3.5	3.4	3.5	3.4	3.5	3.4	3.5	3.5	3.4	3.5	3.4	3.5	3.6	3.4
75	T.C.	45.5	46.9	45.3	50.9	54.7	47.4	48.0	46.0	51.4	55.1	49.4	49.2	46.7	51.9	55.6
	S.C.	42.2	41.2	34.7	35.1	27.7	43.8	43.9	37.0	37.4	29.2	45.4	46.7	39.2	39.7	30.8
	K.W.	3.0	3.0	2.9	3.0	3.0	3.0	3.0	2.9	3.0	3.0	3.0	3.0	2.9	3.0	3.0
85	T.C.	43.2	45.2	42.9	48.2	53.6	45.3	46.1	43.6	48.9	53.6	47.3	47.1	44.2	49.6	53.5
	S.C.	40.1	41.6	33.4	34.2	27.1	42.0	43.5	35.6	36.5	28.4	43.9	45.3	37.9	38.8	29.8
	K.W.	3.2	3.2	3.2	3.2	3.2	3.2	3.2	3.2	3.3	3.2	3.2	3.2	3.2	3.3	3.2
95	T.C.	41.1	42.5	40.2	45.4	49.6	42.8	43.5	40.8	48.5	49.6	44.5	44.4	41.5	46.6	49.6
	S.C.	38.0	39.3	32.2	33.1	25.9	39.7	41.0	34.3	36.5	27.2	41.3	42.8	36.4	37.6	28.6
	K.W.	3.7	3.7	3.7	3.7	3.7	3.7	3.7	3.7	3.7	3.7	3.7	3.7	3.7	3.8	3.7
105	T.C.	38.9	39.8	37.4	42.5	45.6	40.3	40.8	38.1	43.0	45.7	41.8	41.8	38.7	43.5	45.7
	S.C.	36.0	36.9	31.1	32.0	24.7	37.4	38.6	33.0	34.2	26.1	38.8	40.3	34.8	36.5	27.5
	K.W.	4.2	4.2	4.2	4.2	4.3	4.2	4.2	4.2	4.3	4.3	4.2	4.2	4.2	4.3	4.3
115	T.C.	36.8	37.2	34.8	39.7	41.8	37.9	38.2	35.4	40.1	41.9	39.1	39.2	36.0	40.6	42.0
	S.C.	34.0	34.6	30.0	31.0	23.5	35.2	36.2	31.7	33.1	24.9	36.4	37.8	33.3	35.3	26.3
	K.W.	4.6	4.7	4.6	4.7	4.8	4.6	4.7	4.7	4.7	4.8	4.6	4.7	4.7	4.7	4.8
125	T.C.	34.7	34.6	32.1	36.9	37.9	35.5	35.6	32.7	37.3	38.1	36.4	36.6	33.3	37.6	38.2
	S.C.	31.9	32.3	28.9	29.9	22.3	32.9	33.8	30.4	32.0	23.8	33.9	35.4	31.8	34.2	25.2
	K.W.	5.1	5.2	5.1	5.2	5.3	5.1	5.2	5.1	5.2	5.3	5.1	5.2	5.1	5.2	5.3

NOTE: ALL CAPACITIES ARE NET (KBTUH) WITH INDOOR FAN HEAT ALREADY DEDUCTED AT 1250 BTUH/1000 CFM.

### Multipliers for determining the performance with other indoor sections.

NOTE: For dry bulb temperatures different than those listed (between 73-87 F), sensible capacity increases by 1060 BTUH per 1000 CFM per degree above the listed temperature and decreases by 1060 BTUH per 1000 CFM per degree below the listed temperature.

Air Handler	Coil	T.C.	S.C.	KW
N1AHC16	G*FD048S21	0.99	0.98	1.01
N1AHD20	G2FD060(S,H)24	1.00	1.00	1.00
N1AHD20	G2FD061H24	1.01	1.01	1.01
N1VSC16	G2FD048(S,H)21	0.99	0.96	0.97
N1VSD20	G2FD060(S,H)24	1.00	0.98	0.96
N1VSD20	G2FD061H24	1.01	0.99	0.96
F2FP048N		0.98	0.98	1.01
F2FP060N		1.00	1.00	1.01
F2FV060N		1.01	1.00	0.97
	G1FA048S17	0.96	0.95	1.00
	G1FA048S21	0.97	0.96	1.00
	G2FD046(S,H)17	0.96	0.95	1.00
	G2FD048(S,H)21,24	0.99	0.98	1.01
	G2FD060(S,H)24	1.00	1.00	1.00
	G2FD061H24	1.01	1.01	1.01
	G1HA048S21	0.97	0.94	1.00
	G1HD048	0.97	0.96	1.00
	G1UA048S17	0.96	0.95	1.00
	G1UA048S21,24	0.97	0.96	1.00
	G1UA060S21,24	1.00	1.00	1.00

Variable Speed Furnace	Coil	T.C.	S.C.	KW
P1XDC20V	G2FD060(S,H)24	0.98	0.94	0.98
P1XDC20V	G1HA048H21	0.97	0.92	0.98
P1XDC20V	G2FD060(S,H)24	1.00	1.00	0.99
P1XDD20V	G2FD060(S,H)24	1.00	1.00	0.99
P*DUB16V	G1FA048S17	0.96	0.92	0.99
P*DUC20V	G1FA048S21	0.98	0.96	1.00
P*DUC20V	G2FD048(S,H)21	0.99	0.99	0.99
P1XUC16V	G1FA048S21	0.97	0.93	0.99
P1XUC16V	G2FD048(S,H)21	0.98	0.95	0.99
P1XUC20V	G1FA048S21	0.97	0.96	0.99
P1XUC20V	G2FD048(S,H)21	0.99	0.98	1.00
P1XUD20V	G1FA060S24	1.01	1.01	1.00
P1XUD20V	G2FD048(S,H)24	0.99	0.99	1.00
P1XUD20V	G2FD060(S,H)24	1.01	1.01	1.00

<b>COOLING PERFORMANCE DATA</b>																
<b>OUTDOOR UNIT MODEL NO.</b>		<b>CZB06011</b>														
<b>INDOOR COIL MODEL NO.</b>		<b>G1FA060S24</b>														
<b>CONDENSER ENTERING AIR TEMPERATURE</b>	ID CFM	1600					1800					2000				
	ID DB (°F)	80	80	75	80	80	80	80	75	80	80	80	80	75	80	80
	ID WB (°F)	57	62	62	67	72	57	62	62	67	72	57	62	62	67	72
65	T.C.	52.7	53.6	51.5	58.9	62.8	53.7	55.1	53.4	59.6	64.2	54.7	56.5	55.2	60.2	65.5
	S.C.	38.2	47.3	48.8	37.9	29.3	40.8	50.7	49.8	39.9	30.7	43.4	54.2	50.9	41.9	32.1
	K.W.	4.2	4.2	4.1	4.3	4.4	4.2	4.2	4.2	4.3	4.4	4.2	4.2	4.2	4.3	4.4
75	T.C.	56.0	57.8	54.5	62.5	66.8	57.0	59.3	56.4	63.6	67.6	58.0	60.7	58.3	64.8	68.4
	S.C.	39.8	48.7	51.2	39.6	30.4	42.0	51.5	53.4	41.8	31.7	44.3	54.3	55.6	44.1	32.9
	K.W.	3.6	3.6	3.6	3.7	3.7	3.6	3.6	3.6	3.7	3.7	3.6	3.6	3.6	3.7	3.7
85	T.C.	54.4	55.7	53.0	60.7	64.8	55.4	57.2	54.9	61.6	65.9	56.4	58.6	56.7	62.5	66.9
	S.C.	39.0	48.0	50.0	38.7	29.9	41.4	51.1	51.6	40.9	31.2	43.8	54.3	53.2	43.0	32.5
	K.W.	3.9	3.9	3.9	4.0	4.0	3.9	3.9	3.9	4.0	4.1	3.9	3.9	3.9	4.0	4.1
95	T.C.	50.7	52.1	50.1	57.0	60.7	51.6	53.4	51.9	57.0	61.6	52.5	54.8	53.6	58.9	62.5
	S.C.	37.4	45.6	47.3	37.4	28.4	39.6	48.4	48.8	40.8	29.7	41.8	51.2	50.3	41.7	31.0
	K.W.	4.6	4.6	4.5	4.6	4.7	4.6	4.6	4.5	4.5	4.7	4.6	4.6	4.6	4.7	4.7
105	T.C.	47.1	48.5	47.3	53.3	56.5	47.9	49.7	48.9	54.3	57.3	48.6	50.9	50.4	55.3	58.1
	S.C.	35.8	43.3	44.6	36.0	27.0	37.8	45.7	46.0	38.3	28.2	39.8	48.2	47.5	40.5	29.5
	K.W.	5.2	5.2	5.1	5.3	5.4	5.2	5.2	5.2	5.3	5.4	5.2	5.2	5.2	5.3	5.4
115	T.C.	43.6	45.0	44.6	49.7	52.5	44.3	46.1	45.9	50.8	53.2	44.9	47.2	47.3	51.8	53.8
	S.C.	34.2	41.0	42.0	34.7	25.6	36.0	43.1	43.3	37.0	26.8	37.9	45.2	44.7	39.3	28.0
	K.W.	5.8	5.8	5.8	5.9	6.0	5.8	5.8	5.8	5.9	6.0	5.8	5.9	5.8	5.9	6.0
125	T.C.	40.1	41.5	41.8	46.1	48.5	40.6	42.5	43.0	47.2	49.0	41.1	43.4	44.3	48.3	49.5
	S.C.	32.6	38.7	39.3	33.4	24.2	34.2	40.5	40.6	35.8	25.4	35.9	42.3	41.9	38.1	26.5
	K.W.	6.4	6.4	6.4	6.5	6.6	6.4	6.5	6.4	6.5	6.7	6.5	6.5	6.5	6.5	6.7

NOTE: ALL CAPACITIES ARE NET (KBTUH) WITH INDOOR FAN HEAT ALREADY DEDUCTED AT 1250 BTUH/1000 CFM.

### Multipliers for determining the performance with other indoor sections.

NOTE: For dry bulb temperatures different than those listed (between 73-87 F), sensible capacity increases by 1060 BTUH per 1000 CFM per degree above the listed temperature and decreases by 1060 BTUH per 1000 CFM per degree below the listed temperature.

Air Handler	Coil	T.C.	S.C.	KW
N1AHD20	G2FD060(S,H)24	1.00	1.00	1.00
N1AHD20	G2FD061H24	1.01	1.01	1.00
N1VSD20	G2FD060(S,H)24	1.00	0.97	0.98
N1VSD20	G2FD061H24	1.01	0.98	0.98
F2FP060N		0.99	0.96	1.02
F2FV060N		1.00	0.97	0.98
	G2FD060(S,H)24	1.00	1.00	1.00
	G2FD061H24	1.01	1.01	1.00
	G1HA060H24	0.99	0.98	0.99
	G1HD060	0.98	0.97	1.00
	G1UA060S21,24	1.00	1.00	1.00

Variable Speed Furnace	Coil	T.C.	S.C.	KW
P1XCD20V	G2FD060(S,H)24	0.99	0.95	0.98
P1XCD20V	G2FD061H24	1.00	0.95	0.99
P1XDD20V	G2FD060(S,H)24	0.99	0.95	0.98
P1XDD20V	G1HA060H24	0.99	0.95	0.98
P*DUC20V	G1FA060S21	1.00	0.98	0.99
P1XUC20V	G1FA060S21	1.00	1.00	1.00
P1XUD20V	G1FA060S24	0.99	0.96	0.97
P1XUD20V	G2FD060(S,H)24	0.99	0.96	0.97
P1XUD20V	G2FD061H24	1.00	0.97	0.97

**MATCHING INDOOR COMPONENTS**

**ADD-ON COILS - FOR FURNACE APPLICATIONS**

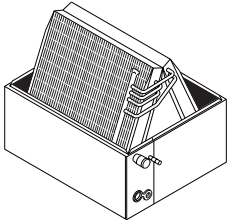

G1UA  
1/2 CASED  
UPFLOW

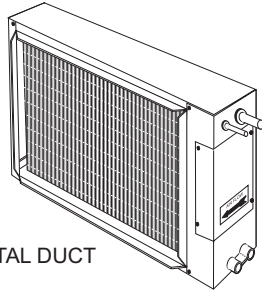

G1HD  
HORIZONTAL DUCT

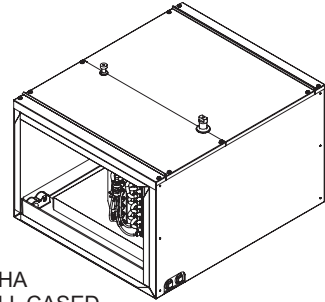

G1HA  
FULL CASED  
HORIZONTAL

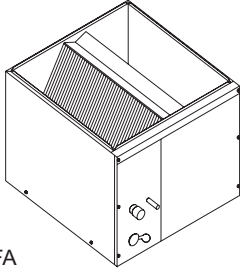

G1FA  
FULL CASED  
UPFLOW

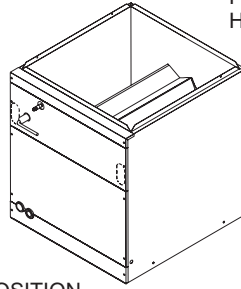

G2FD\*  
MULTI-POSITION  
(UPFLOW, HORIZONTAL  
AND DOWNFLOW)

\* Available with factory installed horizontal drain pan.

**AIR HANDLERS - FOR NON-FURNACE APPLICATIONS**

N-AH OR N-VS  
MODULAR BLOWER  
(UPFLOW, HORIZONTAL  
AND DOWNFLOW)

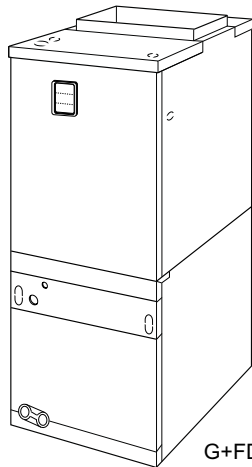

G+FD  
COIL

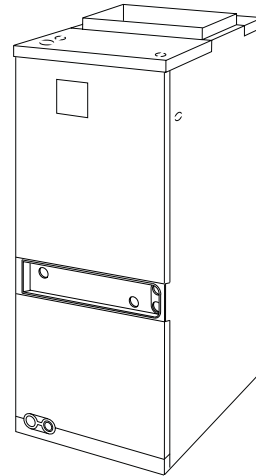

F+RC / F+FC OR  
F+RC / F+FP  
FAN COIL UNITS  
(UPFLOW, HORIZONTAL)

**NOTES**

# NOTES

---

<b>Unitary</b>	<b>5005</b>	<b>Norman</b>
<b>Products</b>	<b>York</b>	<b>OK</b>
<b>Group</b>	<b>Drive</b>	<b>73069</b>