



TECHNICAL GUIDE

AFFINITY

MODELS: PT8

GAS-FIRED HIGH EFFICIENCY TWO STAGE UPFLOW/HORIZONTAL FURNACES

STANDARD & LoNOx

80% AFUE

NATURAL GAS 60 - 120 MBH INPUT



This product was manufactured in a plant whose quality system is certified/registered as being in conformity with ISO 9001.

Due to continuous product improvement, specifications are subject to change without notice.

Visit us on the web at www.york.com for the most up-to-date technical information.

Additional rating information can be found at www.gamanet.org.

DESCRIPTION

These high efficiency, compact units employ induced combustion, reliable hot surface ignition and high heat transfer aluminized tubular heat exchangers. The units are factory shipped for installation in upflow or horizontal applications.

These furnaces are designed for residential installation in a basement, closet, alcove, attic, recreation room or garage and are also ideal for commercial applications. All units are factory assembled, wired and tested to assure safe dependable and economical installation and operation.

These units are Category I listed and may be common vented with another gas appliance as allowed by the National Fuel Gas Code.

WARRANTY

20-year limited warranty on the heat exchanger.

10-year heat exchanger warranty on commercial applications.

5-year limited parts warranty.

FEATURES

- Two stage heating operation includes:
 - Two stage gas valve
 - Two stage inducer operation
- Provides increased comfort level & very quiet unit operation
- Adjustable delay timer allows two stage operation with single stage thermostat
- Compact, easy to install, ideal height 40" cabinet
- Blower-off delay for cooling SEER improvement.
- Easy to connect power/control wiring.
- Built-in, high level self diagnostics with fault code display.
- Low unit amp requirement for easy replacement application.
- Integrated control module for reliable, economical operation.
- High velocity filter and side -return filter rack provided for easy field installation.
- Electronic Hot Surface Ignition saves fuel cost with increased dependability and reliability.
- Induced combustion system with inshot main burners for quiet, efficient operation.
- 100% shut off main gas valve for extra safety.
- PSC -four speed, direct drive motor with large, quiet blower.
- 24V, 40 VA control transformer and blower relay supplied for add-on cooling.
- Hi-tech tubular aluminized steel primary heat exchanger.
- Timed on, adjustable off blower capability for maximum comfort.
- Solid removable bottom panel allows easy application.
- Easy access from front of unit for cleaning, maintenance or service.
- Insulated blower compartment for quiet operation.
- Independent door removal for greater durability and ease of access.
- LoNOx models have been designed to meet specific code requirements.
- LoNOx models may not be converted to propane.

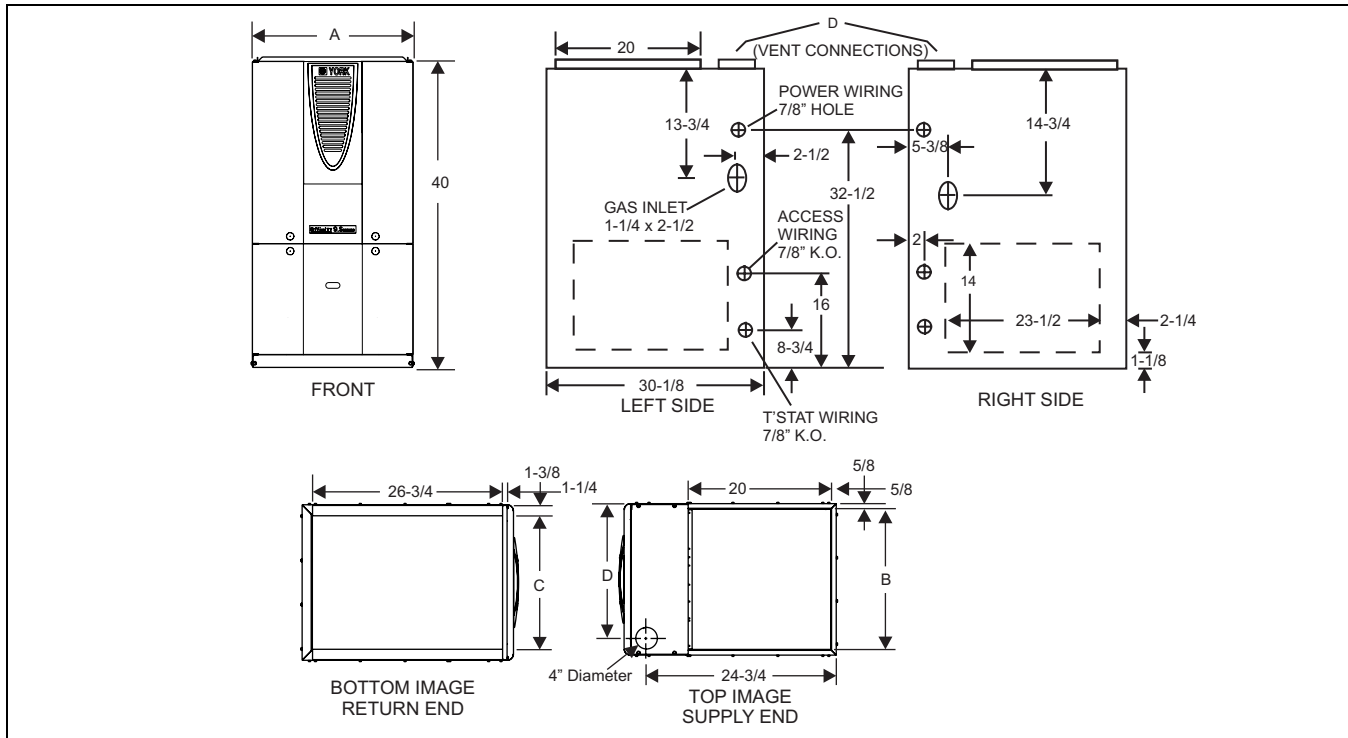

CABINET AND DUCT DIMENSIONS

Model	BTUH Output	CFM	Cabinet Size	Cabinet Dimension			
	MBH			A	B	C	D
PT8A12(N,L)060UH11	46/34	1200	A	14 1/2	13 1/4	10 1/8	10 1/8
PT8A12(N,L)080UH11	64/48	1200	A	14 1/2	13 1/4	10 1/8	10 1/8
PT8B16(N,L)080UH11	64/48	1600	B	17 1/2	16 1/4	13 1/8	11 5/8
PT8B12N100UH11	80/53	1200	B	17 1/2	16 1/4	13 1/8	11 5/8
PT8C20(N,L)100UH11	80/53	2000	C	21	19 3/4	16 5/8	13 3/8
PT8C16N120UH11	96/64	1600	C	21	19 3/4	16 5/8	13 3/8
PT8C20(N,L)120UH11	96/64	2000	C	21	19 3/4	16 5/8	13 3/8

HORIZONTAL VENTING - MUST USE FIELDS CONTROL MODELS SWG-4Y OR TJERENLAND MODEL GPAK-JT FIELD SUPPLIED POWER VENTING KITS

High / Low Fire Inputs	High / Low Fire Outputs	Cabinet	Furnace Airflow	Pipe Size	Min. Vent Length	Max. Vent Length
				Inches		
60/42	46/34	A	1200	4	4.5	34.5
80/59	64/48	A	1200	4	4.5	34.5
80/59	64/48	B	1600	4	4.5	34.5
100/65	80/53	B	1200	4	4.5	34.5
100/65	80/53	C	2000	4	4.5	34.5
120/78	96/64	C	1600	4	4.5	34.5
120/78	96/64	C	2000	4	4.5	34.5

RATINGS & PHYSICAL / ELECTRICAL DATA

Model	Output	Nominal	Cabinet Width	AFUE	Air Temp. Rise		Max. Outlet Air Temp.	
	MBH	CFM	In.		°F		°F	
PT8A12(N,L)060UH11	46/34	1200	14-1/2	80.0	25-55		165	
PT8A12(N,L)080UH11	64/48	1200	14-1/2	80.0	30-60		175	
PT8B16(N,L)080UH11	64/48	1600	17 1/2	80.0	25-55		160	
PT8B12N100UH11	80/53	1200	17 1/2	80.0	25-55		170	
PT8C20(N,L)100UH11	80/53	2000	21	80.0	25-55		160	
PT8C16N120UH11	96/64	1600	21	80.0	25-55		180	
PT8C20(N,L)120UH11	96/64	2000	21	80.0	25-55		170	
Model	Output	Blower		Blower Size	Total Unit	Max Over-current Size (awg) @ 75 ft. protect	Min. Wire one way	Operation WGT.
	MBH	Hp	Amps	In.	Amps			LBS
PT8A12(N,L)060UH11	46/34	1/3	6.2	10 x 7	9.0	20	14	107
PT8A12(N,L)080UH11	64/48	1/3	6.2	10 x 7	9.0	20	14	119
PT8B16(N,L)080UH11	64/48	3/4	11.5	11 x 8	12.0	20	14	129
PT8B12N100UH11	80/53	1/2	7.0	10 x 8	12.0	20	14	131
PT8C20(N,L)100UH11	80/53	1.0	12.2	11 x 10	14.0	20	12	149
PT8C16N120UH11	96/64	1/2	10.4	10 x 10	12.0	20	14	149
PT8C20(N,L)120UH11	96/64	1.0	12.2	11 x 10	14.0	20	12	151

Annual Fuel Utilization Efficiency (AFUE) numbers are determined in accordance with DOE Test procedures.

Wire size and over current protection must comply with the National Electrical Code (NFPA-70-latest edition) and all local codes.

The furnace shall be installed so that the electrical components are protected from water.

FILTER SIZES

Cabinet Size	Side (in)	Bottom (in)
A	16 x 26	14 x 26
B	16 x 26	16 x 26
C	(2) 16 x 26	20 x 26
D	(2) 16 x 26	20 x 26

* ESP (External Static Pressure) .5" WG is at furnace outlet ahead of cooling coil.

NOTES:

1. All filters must be high velocity cleanable type.
2. Air flows above 1800 CFM require either return from two sides or one side plus bottom.

TABLE 1: Blower Performance CFM - Upflow (without filter) - Bottom Return

MODELS Input / CFM	Speed	Two Stage Bottom Airflow Data (SCFM)									
		Ext. Static Pressure (in. H2O)									
		0.1	0.2	0.3	0.4	0.5	0.6	0.7	0.8	0.9	1.0
PT8A12(N,L)060UH11	High	1570	1490	1420	1340	1250	1180	1090	990	870	700
	Medium High	1410	1360	1310	1250	1190	1090	1020	920	810	650
	Medium Low	1200	1180	1150	1100	1050	990	920	830	700	580
	Low	960	960	950	930	900	840	800	720	610	500
PT8A12(N,L)080UH11	High	1590	1520	1460	1380	1300	1240	1150	1050	930	800
	Medium High	1400	1360	1310	1260	1200	1140	1070	960	860	740
	Medium Low	1180	1160	1130	1090	1040	990	920	840	750	640
	Low	940	940	940	920	880	840	790	710	630	530
PT8B16(N,L)080UH11	High	1850	1820	1790	1750	1690	1630	1570	1500	1430	1330
	Medium	1470	1450	1440	1430	1390	1360	1310	1270	1220	1150
	Low	1260	1260	1260	1260	1250	1200	1150	1110	1070	1010
PT8B12N100UH11	High	1700	1620	1560	1480	1390	1300	1210	1110	970	820
	Medium High	1430	1400	1350	1300	1230	1160	1080	980	870	710
	Medium Low	1180	1170	1160	1130	1080	1030	1000	860	750	510
	Low	950	950	930	920	880	840	790	720	620	530
PT8C20(N,L)100UH11	High	2590	2500	2400	2280	2180	2080	1970	1840	1720	1560
	Medium High	2180	2120	2040	1980	1900	1810	1720	1600	1480	1320
	Medium Low	1750	1720	1680	1640	1580	1520	1440	1350	1220	1060
	Low	1450	1420	1380	1330	1300	1240	1160	1070	970	860
PT8C16N120UH11	High	2020	1930	1820	1730	1640	1540	1400	1250	1090	920
	Medium	1750	1710	1650	1590	1490	1390	1290	1160	1010	810
	Low	1540	1500	1460	1410	1350	1260	1180	1060	910	750
PT8C16N120UH11	High	2500	2400	2320	2220	2110	2000	1870	1750	1610	1450
	Medium High	2130	2070	1990	1920	1840	1760	1660	1570	1460	1320
	Medium Low	1700	1680	1650	1620	1560	1500	1410	1320	1210	1070
	Low	1420	1390	1360	1330	1290	1240	1150	1060	950	840

NOTES

1. Airflow expressed in standard cubic feet per minute (CFM) and in cubic meters per minute (m³/min).
2. Motor voltage at 115 V.

* Input / CFM / Cabinet Width (A=14-1/2, B=17-1/2, C=21, D=24-1/2).

TABLE 2: Blower Performance CFM - Upflow (without filter) - Left Side Return

MODELS Input / CFM	Speed	Two Stage Left Side Airflow Data (SCFM)									
		Ext. Static Pressure (in. H2O)									
		0.1	0.2	0.3	0.4	0.5	0.6	0.7	0.8	0.9	1.0
PT8A12(N,L)060UH11	High	1770	1690	1630	1560	1490	1390	1290	1190	1050	920
	Medium High	1400	1380	1350	1320	1280	1230	1160	1060	930	780
	Medium Low	1120	1130	1150	1130	1120	1080	1000	950	790	630
	Low	880	900	900	900	880	850	790	730	660	530
PT8A12(N,L)080UH11	High	1790	1720	1670	1590	1530	1450	1350	1260	1140	1000
	Medium High	1420	1370	1350	1320	1280	1230	1170	1090	990	840
	Medium Low	1080	1120	1110	1100	1080	1040	1000	920	820	690
PT8B16(N,L)080UH11	Low	N/A	900	900	890	870	850	800	730	670	560
	High	2000	1960	1930	1900	1800	1760	1710	1640	1550	1460
	Medium	1440	1440	1430	1420	1400	1380	1340	1300	1220	1150
	Low	1220	1230	1230	1230	1200	1190	1170	1160	1110	1050
PT8B12N100UH11	High	1780	1710	1640	1560	1490	1390	1290	1180	1030	820
	Medium High	1430	1410	1370	1340	1280	1220	1140	1040	890	730
	Medium Low	1140	1170	1150	1120	1080	1040	970	890	760	630
	Low	920	940	950	940	920	890	850	770	660	560
PT8C20(N,L)100UH11	High	2770	2670	2610	2540	2450	2340	2210	2070	1890	1730
	Medium High	2120	2060	2030	2000	1950	1880	1810	1720	1580	1370
	Medium Low	1690	1660	1630	1610	1560	1490	1420	1350	1240	1070
	Low	1390	1370	1330	1290	1250	1200	1120	1010	910	850
PT8C16N120UH11	High	2160	2070	1990	1900	1800	1690	1580	1430	1260	1000
	Medium	1760	1720	1690	1630	1560	1480	1390	1250	1080	890
	Low	1510	1490	1470	1440	1380	1300	1210	1110	950	780
PT8C16N120UH11	High	2740	2650	2560	2480	2380	2280	2170	1990	1840	1650
	Medium High	2120	2090	2040	2000	1940	1870	1780	1680	1550	1370
	Medium Low	1690	1670	1650	1610	1560	1510	1440	1310	1160	1030
	Low	1390	1360	1330	1300	1250	1190	1100	1020	940	840

NOTES

1. Airflow expressed in standard cubic feet per minute (CFM) and in cubic meters per minute (m³/min).
 2. Return air is through side opposite motor (left side).
 3. Motor voltage at 115 V.
- * Input / CFM / Cabinet Width (A=14-1/2, B=17-1/2, C=21, D=24-1/2).

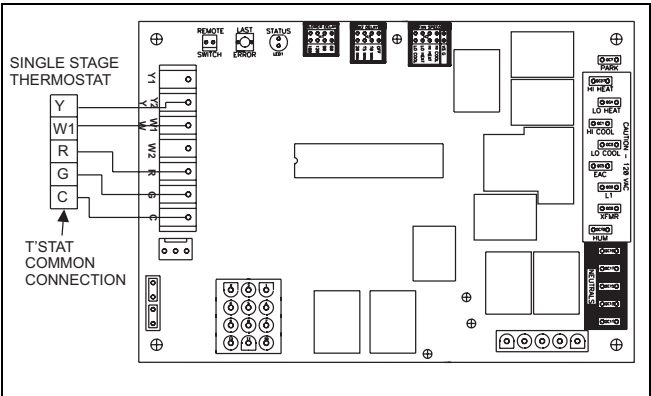
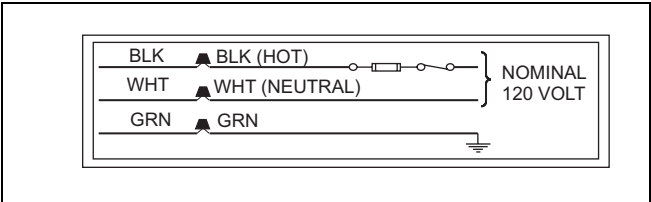

Field Wiring for Single Stage Thermostat

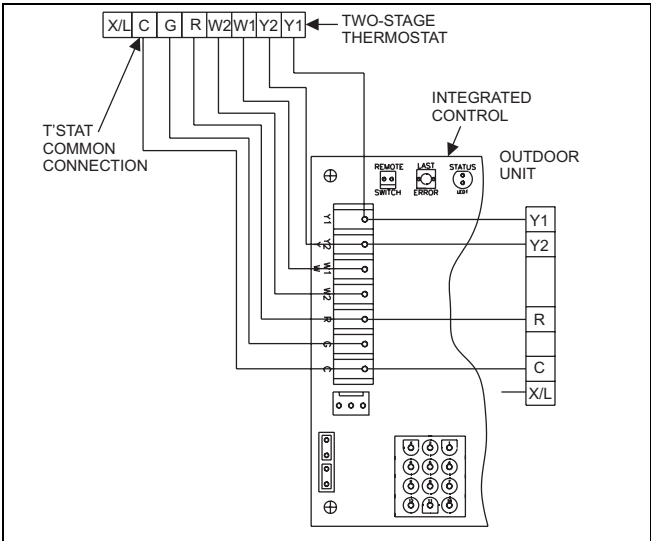

Field Wiring for Two Stage Thermostat

FILTER PERFORMANCE

The airflow capacity data published in the “Blower Performance” table listed above represents blower performance WITHOUT filters. To determine the approximate blower performance of the system, apply the filter drop value for the filter being used or select an appropriate value from the “Filter Performance” table shown below.

NOTE: The filter pressure drop values in the “Filter Performance” table shown below are typical values for the type of filter listed and should only be used as a guideline. Actual pressure drop ratings for each filter type vary between filter manufacturer.

FILTER PERFORMANCE - PRESSURE DROP INCHES W.C.

Airflow Range	Minimum Opening Size		Filter Type					
			Disposable		WASHABLE FIBER*		Pleated	
	1 Opening	2 Openings	1 Opening	2 Openings	1 Opening	2 Openings	1 Opening	2 Openings
CFM	In ³	In ³	inwc	inwc	inwc	inwc	inwc	inwc
0 - 750	230	330	0.01	0.05	0.01	0.05	0.15	0.2
751 - 1000	330		0.05		0.05		0.2	
1001 - 1250	330		0.1		0.1		0.2	
1251 - 1500	330		0.1		0.1		0.25	
1501 - 1750	380	658	0.15	0.09	0.14	0.08	0.3	0.17
1751 - 2000	380	658	0.19	0.11	0.18	0.1	0.3	0.17
2001 & Above	463	658	0.19	0.11	0.18	0.1	0.3	0.17

* Washable fiber are the type supplied with furnace (if supplied).

APPLYING FILTER PRESSURE DROP TO DETERMINE SYSTEM AIRFLOW

To determine the approximate airflow of the unit with a filter in place, follow the steps below:

1. Select the filter type.
2. Select the number of return air openings or calculate the return opening size in square inches to determine the proper filter pressure drop.
3. Determine the External System Static Pressure (ESP) without the filter.
4. Select a filter pressure drop from the table based upon the number of return air openings or return air opening size and add to the ESP from Step 3 to determine the total system static.
5. If total system static matches a ESP value in the airflow table (i.e. 0.20 w.c. (50 Pa), 0.60 w.c. (150 Pa), etc.) the system airflow corresponds to the intersection of the ESP column and Model/Blower Speed row.
6. If the total system static falls between ESP values in the table (i.e. 0.58 w.c. (144 Pa), 0.75 w.c. (187 Pa), etc.), the static pressure may be rounded to the nearest value in the table determining the airflow using Step 5 or calculate the airflow by using the following example.

Example: For a 130,000 BTUH (38.06 kW) furnace with 2 return openings and operating on high-speed blower, it is found that total system static is 0.58” w.c. To determine the system airflow, complete the following steps:

Obtain the airflow values at 0.50 w.c. (125 Pa) & 0.60 w.c. (150 Pa) ESP.

Airflow @ 0.50”: 2125 CFM (60.17 m³/min)

Airflow @ 0.60”: 2035 CFM (57.62 m³/min)

Subtract the airflow @ 0.50 w.c. (125 Pa) from the airflow @ 0.60 w.c. (150 Pa) to obtain airflow difference.

2035 - 2125 = -90 CFM (2.55 m³/min)

Subtract the total system static from 0.50 w.c. (125 Pa) and divide this difference by the difference in ESP values in the table, 0.60 w.c. (150 Pa) - 0.50 w.c. (125 Pa), to obtain a percentage.

(0.58 - 0.50) / (0.60 - 0.50) = 0.8

Multiply percentage by airflow difference to obtain airflow reduction.

(0.8) X (-90) = -72

Subtract airflow reduction value to airflow @ 0.50 w.c. (125 Pa) to obtain actual airflow @ 0.58 inwc (144 Pa) ESP.

2125 - 72 = 2053

UNIT CLEARANCES TO COMBUSTIBLES (ALL DIMENSIONS IN INCHES) (ALL SURFACES IDENTIFIED WITH THE UNIT IN AN UPFLOW CONFIGURATION)

APPLICATION	TOP	FRONT	REAR	LEFT SIDE	RIGHT SIDE	FLUE	FLOOR/ BOTTOM	CLOSET	ALCOVE	ATTIC	LINE CONTACT
	In.	In.	In.	In. (cm)	In. (cm)	In. (cm)					
UPFLOW	1	6	0	0	3 ¹	6	COMBUSTIBLE	YES	YES	YES	NO
UPFLOW B-VENT	1	3	0	0	0	1	COMBUSTIBLE	YES	YES	YES	NO
HORIZONTAL	3 ²	6	0	1	0	6	COMBUSTIBLE	NO	YES	YES	YES ³
HORIZONTAL B-VENT	0	3	0	1	0	1	COMBUSTIBLE	NO	YES	YES	YES ³

1 14-1/2” cabinet models only. All other units “0” clearance.

2 14-1/2” cabinet left airflow applications only. All other units and right hand airflow applications “0” clearance.

3 Line contact only permitted between lines formed by the intersection of the rear panel and side panel (top in horizontal position) of the furnace jacket and building joists, studs or framing.

ACCESSORIES

PROPANE (LP) CONVERSION KIT -

1NP0480 - All units

This accessory conversion kit may be used to convert natural gas (N) units for propane (LP) operation. Conversions must be made by qualified distributor or dealer personnel.

EXTERNAL BOTTOM RETURN FILTER RACK W/FILTER -

Provides a cleanable, high velocity type filter and filter rack. Attaches to the bottom of the furnace.

1BR0314 - For 14-1/2" cabinets

1BR0317 - For 17-1/2" cabinets

1BR0321 - For 21" cabinets

1BR0324 - For 24-1/2" cabinets

HIGH ALTITUDE PRESSURE SWITCHES -

Used to convert units for operation at altitudes from 4,500 ft. to 10,000 ft.

Input (MBH)	Output (MBH)	2,000 Ft. to 5,500 Ft.	>5,500 Ft. to 0,000 Ft.
40	32	1PS0301	1PS0301
60	48	1PS0301	1PS0301
80	64	1PS0302	1PS0302
100	80	1PS0312	1PS0311
115	92	1PS0312	1PS0311
130	104	1PS0312	1PS0311

FIELD INSTALLED ACCESSORIES- ELECTRICAL		
MODEL NO.	DESCRIPTION	USED WITH
2ET0770010124	THERMOSTAT-Two-stage Heat/ Cool, deluxe 24V	ALL MODELS
2TH04701024	THERMOSTAT- Two-stage Heat/Cool, Auto or manual changeover. System Switch: Heat-Off-Cool-Auto. Fan Switch: On-Auto.	ALL MODELS
2ET07700424	THERMOSTAT-Two-stage Heat/Cool. Programmable electronic (5+1+1), Auto or manual changeover. System Switch:Heat-Off-Cool-Auto. Fan Switch: Auto-On.	ALL MODELS
2TC03700124	TWINNING CONTROL	ALL MODELS

NOTES