

SUBMITTAL DATA SHEET



Heating and Air Conditioning

SPLIT SYSTEM CONDENSING UNITS

14 SEER - 2 thru 3 TON

MODELS: H*RE024 & H*RE036 FRCS

| | | | | | |
|-------------------|--|------|--------------|-----------|---------------|
| JOB NAME: | | | LOCATION: | | |
| PURCHASER: | | | ORDER NO.: | | |
| ENGINEER: | | | | | |
| SUBMITTED TO: | | FOR: | REF: | APPROVAL: | CONSTRUCTION: |
| SUBMITTED BY: | | | DATE: | | |
| UNIT DESIGNATION: | | | SCHEDULE NO. | MODEL NO. | |

PRODUCT DATA

Cooling Performance

Total Capacity _____ MBH

Outdoor Design Temp _____ °F

Electrical Data

Power Supply _____ / / _____

Total Unit Ampacity _____ AMPs

Power Input Req _____ KW

Minimum Wire Size _____ AWG

Maximum Overcurrent Device

Fuses Circuit Breaker

Unit Weight

Unit Weight _____ LBS

DIMENSIONS - INCHES

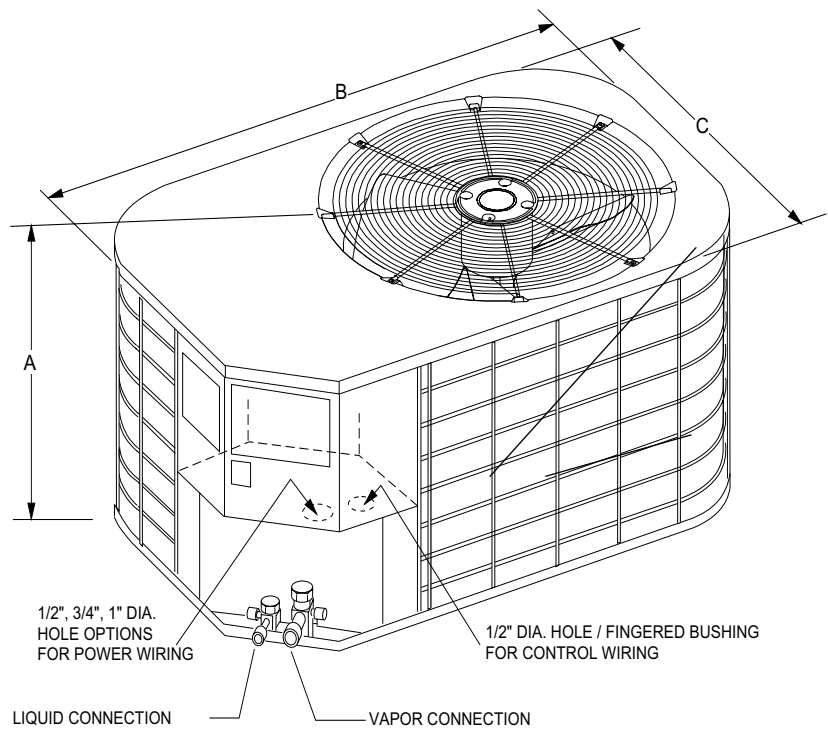

| UNIT MODEL | DIMENSIONS | | | REFRIGERANT CONNECTION | |
|------------|------------|----|----|------------------------|-------|
| | A* | B | C | LINE SIZE | |
| | | | | LIQUID | VAPOR |
| 024 | 33 | 37 | 27 | 3/8 | 7/8 |
| 030 | 39 | 37 | 27 | | |
| 036 | 39 | 37 | 27 | | |

*. Includes fan guard

All dimensions are in inches. They are subject to change without notice. Certified dimensions will be provided upon request.

