

JOB NAME _____ LOCATION _____
 PURCHASER _____ ORDER NO. _____
 ENGINEER _____
 SUBMITTED TO _____ FOR: Reference Approval Construction
 SUBMITTED BY _____ DATE _____

UNIT DESIGNATION: Schedule No. _____ MODEL NO. _____

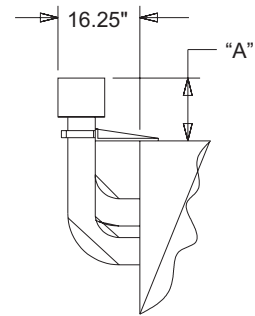
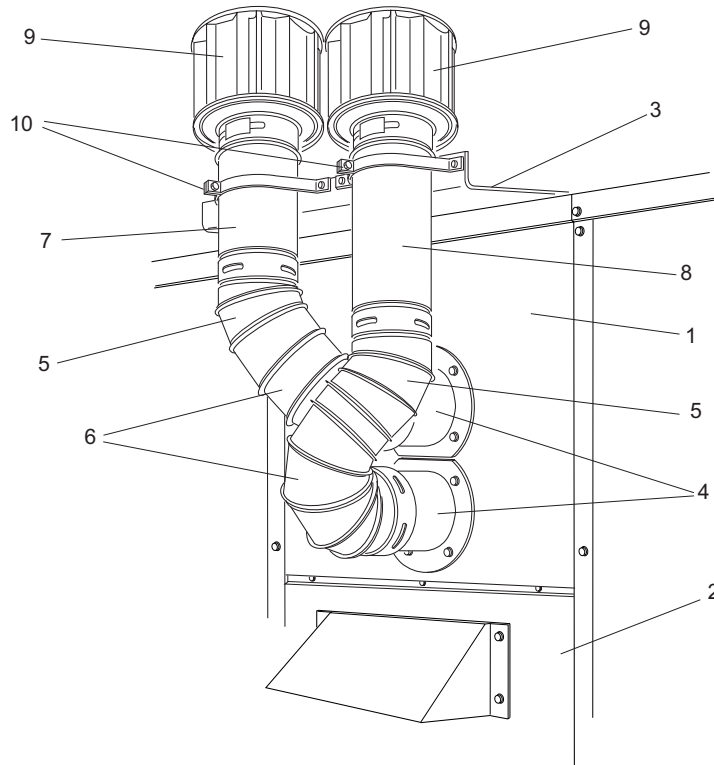

ITEM	QTY.	PART NUMBER	DESCRIPTION
1	1	073-18730-001	PANEL, TOP, GAS HEAT (FOR KIT 1FE0409 ONLY)
1	1	073-18730-002	PANEL, TOP, GAS HEAT (FOR KIT 1FE0410 ONLY)
2	1	073-18731-000	PANEL, BOTTOM, GAS HEAT
3	1	073-18751-000	BRACKET, FLUE STACK
4	2	026-34699-000	COLLAR, START, 6"
5	2	026-34700-000	B-VENT, 45 DEG. EL, 6" ADJ.
6	2	026-34701-000	B-VENT, 90 DEG. EL, 6" ADJ.
7	1	026-34702-000	B-VENT, STR., 6" DIA., 12" LG.
8	1	026-34703-000	B-VENT, STR., 6" DIA., 18" LG.
9	2	026-34705-000	B-VENT, CAP, 6" DIA.
10	2	026-34706-000	BRACKET, WALL, 6"

UNIT MODEL	UNIT SIZE	DIMENSION "A"
DCG 180, DHG 180, DM 180, DH 180	15 TON	20"
DCG 240, DHG 240, DM 240, DH 240	20 TON	16"
DCG 300, DM 300	25 TON	16"
DJ 180, 210, 240, 300	15, 17.5, 20, 25 TON	16"
DR180, 240, 300	15, 20, 25 TON	16"

Subject to change without notice. Printed in the U. S. A.

FLUE EXHAUST KIT
MODEL 1FE0409 AND 1FE0410
 FOR SINGLE PACKAGE ROOFTOP AIR CONDITIONERS
 15 THRU 25 TON UNITS

036-22220-001-B-0203

Supersedes: 036-22220-001-A-0502

