



# YORK®

## Heating and Air Conditioning

### TECHNICAL GUIDE

**AFFINITY**  
**SPLIT-SYSTEM AIR CONDITIONERS**  
**13 SEER – R-410A**  
**MODELS:**  
**CZB018 THRU 060**  
**(1.5 THRU 5 NOMINAL TONS)**



Due to continuous product improvement, specifications are subject to change without notice.

Visit us on the web at [www.york.com](http://www.york.com)

Additional rating information can be found at [www.ari.org/aridirectory](http://www.ari.org/aridirectory)

### DESCRIPTION

The CZB Series condensing unit is the outdoor part of a versatile air conditioning system. It is designed to be custom matched with one of our complete line of evaporator sections, each designed to serve a specific function. Matching air handlers are available for upflow, downflow, and horizontal left or right application to provide a complete system. Electric heaters are available if required. Add-on coils are available for use with upflow, downflow, or horizontal furnaces. Field installed accessories are available as needed.

### WARRANTY

*5-year limited parts warranty.*

*10-year limited compressor warranty.*

### FEATURES

- **Superior Coil Protection** – A stamped decorative metal coil guard completely protects coil from debris and other large damaging material while a polymer mesh further protects the coil against smaller particles.
- **Color Grilles** - Engineered around the needs and wants of the consumer, Affinity units are now available with a choice of color options designed to compliment any home.
- **Isolated Compressor Compartment** – A molded composite bulkhead isolates the compressor from the rest of the unit reducing sound and vibration.
- **Protected Compressors** – Each compressor is protected against abnormal pressures by an internal pressure relief valve and factory installed high and low pressure controls. Additional protection against moisture and debris is provided by factory installed liquid line filter driers.
- **Environmentally Friendly Refrigerant** – Next generation refrigerant R-410A delivers environmentally friendly performance with zero ozone depletion.
- **Durable Finish** – Automotive quality finish provides the ultimate protection from harmful U.V. rays and rust creep ensuring long-lasting high quality appearance. A powder-paint topcoat is applied over a baked-on primer, using a galvanized, zinc coated steel base material. The result is a finish that has been proven in testing to provide 33% greater durability than conventional powder-coat finishes.
- **Lower Installed Cost** – Designed to provide enhanced installability by featuring a slide-down control compartment and angled service valves to reduce overall installation time and cost.
- **Low Operating Sound Levels** – A fan design boasting technology adapted from aeronautic and defense engineering provides for whisper quiet operation by allowing airflow to flow smoothly and efficiently across the fan tips.
- **Filter-Drier** – A factory installed, solid core liquid line filter-drier filters harmful debris and moisture from the system.
- **Easy Service Access** – A full end, full service, access panel with handle makes for easy entry to internal components.
- **Composite Base** - Strong and durable composite base pan resists rust and corrosion while it helps reduce vibrations and noise.
- **Quiet drive system** - Features combination of swept-wing fan, composite base pan, isolated compressor compartment and two-stage compressor to reduce overall sound to a mere whisper.
- **Low RPM fan motor** - Helps to reduce airflow noise.

Certified in accordance with the Unitary Small Equipment certification program, which is based on ARI Standard 210/240.

**PHYSICAL AND ELECTRICAL DATA**

MODEL	CZB01811	CZB02411	CZB03011	CZB03611	CZB04211	CZB04811	CZB06011	
Unit Supply Voltage	208-230V, 1 $\phi$ , 60Hz							
Normal Voltage Range <sup>1</sup>	187 to 252							
Minimum Circuit Ampacity	13.3	16.5	18.9	22.3	28.7	27.9	34.4	
Max. Overcurrent Device Amps <sup>2</sup>	20	25	30	35	50	45	60	
Min. Overcurrent Device Amps <sup>3</sup>	15	20	20	25	30	30	35	
Compressor Type	Scroll	Scroll	Scroll	Scroll	Scroll	Scroll	Scroll	
Compressor Amps	Rated Load	10.3	14.3	16.4	16.6	21.8	21.1	26.3
	Locked Rotor	51	60	73	88	105	113	150
Crankcase Heater	No	No	No	No	No	No	No	
Fan Motor Amps	Rated Load	0.5	0.5	0.5	1.5	1.5	1.5	1.5
Fan Diameter Inches	22	22	22	22	22	22	22	
Fan Motor	Rated HP	1/15	1/15	1/15	1/4	1/4	1/4	1/4
	Nominal RPM	850	850	850	850	850	850	850
	Nominal CFM	2100	2,250	2,300	3,200	3,250	3,500	3,500
Coil	Face Area Sq. Ft.	14.86	14.86	17.15	17.15	20.58	20.58	20.58
	Rows Deep	1	1	1	1	1	1	2
	Fins / Inch	22	22	22	22	22	22	22
Liquid Line Set OD (Field Installed)	3/8	3/8	3/8	3/8	3/8	3/8	3/8	
Vapor Line Set OD (Field Installed)	3/4	3/4	3/4	3/4	7/8	7/8	7/8	
Unit Charge (Lbs. - Oz.) <sup>4</sup>	5-13	6-4	7-4	6-4	8-13	8-12	13-9	
Charge Per Foot, Oz.	0.62	0.62	0.62	0.62	0.67	0.67	0.67	
Operating Weight Lbs.	165	170	190	190	205	215	260	

- 1 Rated in accordance with ARI Standard 110, utilization range "A".
- 2 Dual element fuses or HACR circuit breaker. Maximum allowable overcurrent protection.
- 3 Dual element fuses or HACR circuit breaker. Minimum recommended overcurrent protection.
- 4 The Unit Charge is correct for the outdoor unit, matched indoor coil and 15 feet of refrigerant tubing. For tubing lengths other than 15 feet, add or subtract the amount of refrigerant, using the difference in length multiplied by the per foot value.

All dimensions are in inches. They are subject to change without notice. Certified dimensions will be provided upon request.

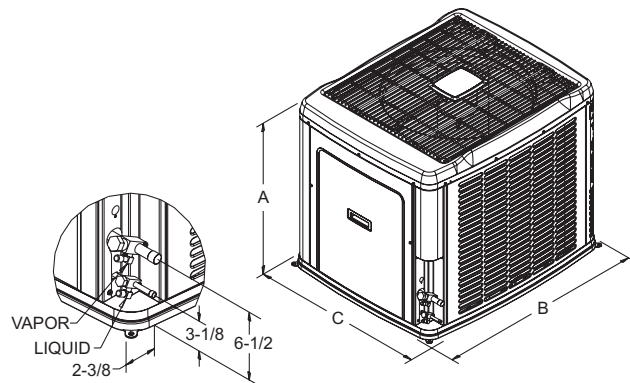
**DIMENSIONS**

Unit Model	Dimensions (Inches)			Refrigerant Connection Service Valve Size	
	A	B	C	Liquid	Vapor
018	29-1/2	37	31	3/8"	3/4"
024	29-1/2	37	31		
030	33-1/2	37	31		
036	33-1/2	37	31		
042	39-1/2	37	31		
048	39-1/2	37	31	7/8"	
060	39-1/2	37	31		

Additional R-410A Charge / TXV Size for Various Matched Systems							
Outdoor Unit	CZB01811	CZB02411	CZB03011	CZB03611	CZB04211	CZB04811	CZB06011
Unit Orifice (s)	1TVM901	1TVM903	1TVM903	1TVM903	1TVM904 1TVM4C1	1TVM905	1TVM905
Factory R-410A Charge, lbs-oz	5-13	6-4	7-4	6-4	8-13	8-12	13-9
Indoor Coil <sup>1,2</sup>	Additional Charge, Oz						
FC/MC/PC/UC18A3X	5	–	–	–	–	–	–
FC/MC/PC/UC18B3X	5	–	–	–	–	–	–
FC/MC/PC/UC24A3X	5	6	–	–	–	–	–
FC/MC/PC/UC24B3X	5	6	–	–	–	–	–
FC/MC/PC/UC30A3X	5	6	3	–	–	–	–
FC/MC/PC/UC30B3X	5	6	3	–	–	–	–
FC/MC/PC/UC36A3X	–	–	3	3	–	–	–
FC/MC/PC/UC36B3X	–	–	3	3	–	–	–
FC/MC/PC/UC36C3X	–	–	3	3	–	–	–
FC/MC/PC35B3X	–	–	–	3	–	–	–
FC/MC/PC35C3X	–	–	–	3	–	–	–
FC/MC/PC/UC42B3X	–	–	–	3	–	–	–
FC/MC/PC/UC42C3X	–	–	–	3	–	–	–
FC/MC/PC/UC48C3X	–	–	–	–	6	–	–
FC/MC/PC/UC48D3X	–	–	–	–	6	–	–
FC/PC/UC60C3X	–	–	–	–	–	12	4
FC/MC/PC/UC60D3X	–	–	–	–	–	12	4
MC61D3X	–	–	–	–	–	–	4
HC18A3X	5	–	–	–	–	–	–
HC30A3X	–	6	–	–	–	–	–
HC36B3X	–	–	3	3	–	–	–
HC60D3X	–	–	–	–	6	12	4
HD24A3X	–	–	–	–	–	–	–
HD36B3X	–	–	3	3	–	–	–
HD48C3X	–	–	–	–	6	–	–
HD60D3X	–	–	–	–	–	12	4
AHP18B3X	5	–	–	–	–	–	–
AHP24B3X	5	6	–	–	–	–	–
AHP30B3X	–	–	3	–	–	–	–
AHP36C3X	–	–	3	3	–	–	–
AHP42C3X	–	–	–	3	–	–	–
AHP/SHP48D3X	–	–	–	–	6	12	–
AHP/SHP60D3X	–	–	–	–	6	12	4
AV24B3X	5	6	–	–	–	–	–
AV36C3X	–	–	3	3	–	–	–
AV/SV48D3X	–	–	–	–	6	12	–
AV/SV60D3X	–	–	–	–	–	12	4

**FOOTNOTES:**

- 1 Systems matched with furnace or air handlers not equipped with blower-off delays may require blower Time Delay Kit 2FD06700224.
- 2 PC coils cannot be used in downflow or horizontal applications. FC coils cannot be used in horizontal applications.

**PROCEDURES:**

1. Unit factory charge listed on the unit nameplate includes refrigerant for the condenser, the smallest evaporator and 15 feet of interconnecting line tubing.
2. Verify the TXV and additional charge required for specific evaporator coil in the system using the above table.
3. Additional charge for the amount of interconnecting line tubing greater than 15 feet at the rate specified in the Physical and Electrical Data Table.
4. Permanently mark the unit nameplate with the total system charge. Total System Charge = Base Charge (as shipped) + adder for evaporator + adder for line set.

**COOLING CAPACITY - With Air Handler Coils**

UNIT MODEL	AIR HANDLER		COIL MODEL <sup>1</sup>	COOLING				
	MODEL	W		RATED CFM	NET MBH		SEER	EER
					TOTAL	SENS.		
<b>1 PH 13 SEER AC WITH MA</b>								
CZB01811	MA08B	17	FC/MC18B	600	18.0	12.1	13.00	11.00
	MA08B	17	FC/MC24B	600	18.0	12.1	13.00	11.00
	MA08B	17	FC/MC30B	600	18.0	12.1	13.00	11.00
CZB02411	MA08B	17	FC/MC24B	800	23.2	16.9	13.00	11.00
	MA08B	17	FC/MC30B	800	23.2	16.9	13.00	11.00
CZB03011	MA12B	17	FC/MC30B	1000	29.8	21.7	13.00	11.00
	MA12B	17	FC/MC36B	1000	30.0	21.9	13.00	11.00
CZB03611	MA12B	17	FC/MC35B	1200	36.0	26.5	13.00	11.00
	MA12B	17	FC/MC36B	1200	35.6	26.3	13.00	11.00
	MA12B	17	FC/MC42B	1200	36.0	26.5	13.00	11.00
CZB04211	MA16C	21	FC/MC48C	1400	41.0	30.2	13.00	11.00
	MA14D	24	FC/MC48D	1400	41.0	30.2	13.00	11.00
CZB04811	MA20D	24	FC/MC60D	1600	48.0	35.8	13.00	11.00
	MA16C	21	FC60C	1600	48.0	35.8	13.00	11.00
CZB06011	MA20D	24	FC/MC60D	1800	55.5	39.7	13.00	11.00
	MA20D	24	MC61D	1800	56.0	40.0	13.00	11.00
<b>1 PH 13 SEER AC WITH MV - VARIABLE SPEED</b>								
CZB01811	MV12B	17	MC18B	600	18.1	12.1	14.00	11.50
CZB02411	MV12B	17	MC24B	825	23.2	16.9	14.00	11.50
CZB03011	MV12B	17	MC36B	1000	30.6	22.3	14.00	11.50
CZB03611	MV12B	17	MC36B	1200	36.0	26.5	13.50	11.00
	MV12B	17	MC42B	1200	36.2	26.7	13.80	11.00
CZB04211	MV16C	21	MC48C	1380	41.5	30.5	13.50	11.00
	MV20D	24	MC48D	1380	41.5	30.5	13.50	11.00
CZB04811	MV20D	24	MC60D	1600	48.5	36.1	13.25	11.00
CZB06011	MV20D	24	MC60D	1780	55.5	39.7	13.10	11.00
	MV20D	24	MC61D	1780	57.5	41.1	13.25	11.00
<b>1 PH 13 SEER AC WITH AHP/ SHP / F*FP</b>								
CZB01811	AHP18	17	-	600	18.0	12.1	13.00	11.00
	AHP24	17	-	600	18.0	12.3	13.00	11.00
	F*FP024	17	-	600	18.0	12.1	13.00	11.00
CZB02411	AHP24	17	-	800	23.0	16.9	13.00	11.00
CZB03011	AHP30	17	-	1000	30.0	21.9	13.00	11.00
	AHP36	17	-	1000	30.0	21.9	13.00	11.00
	F*FP036	21	-	1000	30.0	22.3	13.00	11.00
CZB03611	AHP36	17	-	1200	36.0	26.5	13.00	11.00
	AHP42	21	-	1200	36.0	26.5	13.00	11.00
	F*FP036	21	-	1200	36.0	26.7	13.00	11.00
	F*FP048	21	-	1200	36.0	26.8	13.00	11.00
CZB04211	AHP/SHP48	24	-	1400	41.5	30.5	13.00	11.00
	AHP/SHP60	24	-	1400	41.5	30.5	13.00	11.00
	F*FP048	24	-	1400	41.0	30.2	13.00	11.00
CZB04811	AHP/SHP48	24	-	1600	48.0	36.1	13.00	11.00
	AHP/SHP60	24	-	1600	48.0	36.1	13.00	11.00
CZB06011	AHP/SHP60	24	-	1800	55.5	39.7	13.00	11.00

For Notes See Page 5

**COOLING CAPACITY - With Air Handler Coils (Continued)**

UNIT MODEL	AIR HANDLER		COIL MODEL <sup>1</sup>	COOLING				
	MODEL	W		RATED CFM	NET MBH		SEER	EER
					TOTAL	SENS.		
<b>1 PH 13 SEER AC WITH AV / SV / F*FV VARIABLE SPEED</b>								
CZB01811	AV24	17	–	600	18.0	12.1	14.00	11.50
CZB02411	AV24	17	–	800	23.0	16.7	14.00	11.50
CZB03011	AV36	17	–	1000	30.0	21.9	14.00	11.50
CZB03611	AV36	17	–	1200	36.0	26.5	14.00	11.50
CZB04211	AV/SV48	24	–	1400	41.5	30.5	14.00	11.50
CZB04811	AV/SV48	24	–	1600	48.0	35.8	14.00	11.50
	AV/SV60	24	–	1600	48.0	35.8	14.00	11.50
	F*FV060	24	–	1600	48.0	36.5	13.25	11.00
CZB06011	AV/SV60	24	–	1800	57.0	40.8	14.00	11.50
	F*FV060	24	–	1780	55.5	40.8	13.25	11.00

Rated in accordance with DOE test procedures (Federal Register 12-27-79 and 3-18-88) and ARI Standards 210.

Cooling MBH based on 80°F entering air temperature, 50% RH, and rated air flow.

EER (Energy Efficiency Ratio) is the total cooling output in BTU's at 95°F outdoor ambient divided by the total electric power in watt-hours at those conditions.

SEER (Seasonal Energy Efficiency Ratio) is the total cooling output in BTU's during a normal annual usage period for cooling divided by the total electric power input in watt-hours during the same period.

1 MC coils available with a factory installed horizontal drain pan. See price pages for specific model number.

Go to [www.ari.org/aridirectory](http://www.ari.org/aridirectory) for the latest additional matches.

**COOLING CAPACITY - Upflow, Downflow & Horizontal Furnaces and Coils**

UNIT MODEL	FURNACE		COIL MODEL	COOLING				
	CFM RANGE (MIN.-MAX.)	W		RATED CFM	NET MBH		SEER <sup>1,2</sup>	EER
					TOTAL	SENS.		
CZB01811	450 750	14,17	FC/MC/PC/UC18	600	18.0	12.1	13.00	11.00
		14,17	FC/MC/PC/UC24	600	18.0	12.1	13.00	11.00
		14,17	FC/MC/PC/UC30	600	18.0	12.1	13.00	11.00
		14	HC18	570	18.0	12.1	13.00	11.00
CZB02411	600 1000	14,17	FC/MC/PC/UC24	800	23.2	16.9	13.00	11.00
		14,17	FC/MC/PC/UC30	800	23.2	16.9	13.00	11.00
		14	HC30	760	22.6	16.5	13.00	11.00
		–	HD24	800	22.6	16.5	13.00	11.00
CZB03011	800 1200	14,17	FC/MC/PC/UC30	1000	29.8	21.7	13.00	11.00
		14,17,21	FC/MC/PC/UC36	1000	30.0	21.9	13.00	11.00
		17	HC36	950	30.0	21.9	13.00	11.00
		–	HD36	1000	30.0	21.9	13.00	11.00
CZB03611	1000 1400	17, 21	FC/MC/PC/UC35	1200	36.0	26.5	13.00	11.00
		14,17,21	FC/MC/PC/UC36	1200	35.6	26.3	13.00	11.00
		17,21	FC/MC/PC/UC42	1200	36.0	26.5	13.00	11.00
		17	HC36	1140	36.0	26.5	13.00	11.00
		–	HD36	1200	35.8	26.4	13.00	11.00
CZB04211	1200 1600	21,24	FC/MC/PC/UC48	1400	41.0	30.2	13.00	11.00
		24	HC60	1330	40.5	29.8	13.00	11.00
		–	HD60	1400	40.0	29.4	13.00	11.00
CZB04811	1400 1800	21,24	FC/MC/PC/UC60	1600	48.0	35.8	13.00	11.00
		24	HC60	1600	48.0	35.8	13.00	11.00
		–	HD60	1600	48.0	35.8	13.00	11.00
CZB06011	1600 2000	21,24	FC/MC/PC/UC60	1800	55.5	39.7	13.00	11.00
		24	HC60	1800	55.5	39.7	13.00	11.00
		–	HD60	1800	55.5	39.7	13.00	11.00
		24	MC61	1800	56.0	40.0	13.00	11.00

1 Requires a 2FD06700224 Blower Time Delay unless a standard furnace is equipped with one.

2 TXV = Use 1TV900 series kit.

**COOLING CAPACITY - With Variable Speed Furnaces**

UNIT MODEL	VARIABLE SPEED FURNACE MODEL	COIL MODEL <sup>1</sup>	W	COOLING				
				RATED CFM	NET MBH		SEER	EER
					TOTAL	SENS.		
<b>1 PH 13 SEER AC WITH VARIABLE SPEED FURNACES<sup>2</sup></b>								
CZB01811	PV8*A12	FC/MC/PC24A	14	600	18.0	12.2	14.00	11.50
	PV9*A12	FC/MC/PC24A	14	600	18.0	12.2	14.00	11.50
	P(C,V)9*B12	FC/MC/PC24B	17	600	18.0	12.2	14.00	11.50
	PV8*A12	FC/MC/PC30A	14	600	18.0	12.2	14.00	11.50
	PV9*A12	FC/MC/PC30A	14	600	18.0	12.2	14.00	11.50
	P(C,V)9*B12	FC/MC/PC30B	17	600	18.0	12.2	14.00	11.50
	PV8*A12	HC18	14	600	18.0	12.2	14.00	11.50
	PV9*A12	HC18	14	600	18.0	12.2	14.00	11.50
CZB02411	PV8*A12	FC/MC/PC24A	14	800	23.6	17.2	14.00	11.50
	PV9*A12	FC/MC/PC24A	14	800	23.6	17.2	14.00	11.50
	P(C,V)9*B12	FC/MC/PC24B	17	800	23.6	17.2	14.00	11.50
	PV8*A12	FC/MC/PC30A	14	800	23.6	17.2	14.00	11.50
	PV9*A12	FC/MC/PC30A	14	800	23.6	17.2	14.00	11.50
	P(C,V)9*B12	FC/MC/PC30B	17	800	23.6	17.2	14.00	11.50
	PV8*A12	HC30	14	800	22.8	16.6	14.00	11.50
	PV9*A12	HC30	14	800	22.8	16.6	14.00	11.50
	PV8*A12	HD24	14	800	22.8	16.6	14.00	11.50
PV9*A12	HD24	14	800	22.8	16.6	14.00	11.50	
CZB03011	PV8*A12	FC/MC/PC30A	14	1000	30.0	21.9	13.50	11.00
	PV9*A12	FC/MC/PC30A	14	1000	30.0	21.9	13.50	11.00
	PV8*B16	FC/MC/PC30B	17	1000	30.0	21.9	13.50	11.00
	P(C,V)9*B12	FC/MC/PC30B	17	1000	30.0	21.9	13.50	11.00
	PV8*A12	FC/MC/PC36A	14	1000	30.0	22.3	14.00	11.50
	PV9*A12	FC/MC/PC36A	14	1000	30.0	22.3	14.00	11.50
	PV8*B16	FC/MC/PC36B	17	1000	30.0	22.3	14.00	11.50
	P(C,V)9*B12	FC/MC/PC36B	17	1000	30.0	22.3	14.00	11.50
	PV8*C16	FC/MC/PC36C	21	1000	30.0	22.3	14.00	11.50
	P(C,V)9*C16	FC/MC/PC36C	21	1000	30.0	22.3	14.00	11.50
	PV8*B16	HC36	17	1050	30.0	22.0	14.00	11.50
	P(C,V)9*B12	HC36	17	1050	30.0	22.0	14.00	11.50
	PV8*C16	HD36	21	1050	30.0	22.0	14.00	11.50
P(C,V)9*C16	HD36	21	1050	30.0	22.0	14.00	11.50	
CZB03611	PV8*A12	FC/MC/PC36A	14	1200	35.0	25.8	13.25	11.00
	PV9*A12	FC/MC/PC36A	14	1200	35.8	26.4	13.50	11.00
	PV8*B16	FC/MC/PC36B	17	1200	36.0	26.5	13.50	11.00
	P(C,V)9*B12	FC/MC/PC36B	17	1200	35.8	26.4	13.50	11.00
	PV8*C16	FC/MC/PC36C	21	1200	36.0	26.5	13.50	11.00
	PV8*C20	FC/MC/PC36C	21	1200	36.0	26.5	13.50	11.00
	P(C,V)9*C16	FC/MC/PC36C	21	1200	35.8	26.4	13.50	11.00
	P(C,V)9*C20	FC/MC/PC36C	21	1200	35.8	26.4	13.50	11.00
	PV8*B16	FC/MC/PC42B	17	1200	36.0	27.3	13.50	11.00
	P(C,V)9*B12	FC/MC/PC42B	17	1200	36.0	26.7	13.50	11.00
	PV8*C16	FC/MC/PC42C	21	1200	36.0	27.3	13.50	11.00
	PV8*C20	FC/MC/PC42C	21	1200	36.0	27.3	13.50	11.00
	PV8*B16	HC36	17	1200	36.0	26.5	13.25	11.00
	P(C,V)9*B12	HC36	17	1200	36.0	26.5	13.25	11.00
	PV8*C16	HD36	21	1200	36.0	26.5	13.25	11.00
	P(C,V)9*C16	HD36	21	1200	36.0	26.5	13.25	11.00
	P(C,V)9*C20	HD36	21	1200	36.0	26.5	13.25	11.00

For Notes See Page 7.

**COOLING CAPACITY - With Variable Speed Furnaces**

UNIT MODEL	VARIABLE SPEED FURNACE MODEL	COIL MODEL <sup>1</sup>	W	COOLING				
				RATED CFM	NET MBH		SEER	EER
					TOTAL	SENS.		
<b>1 PH 13 SEER AC WITH VARIABLE SPEED FURNACES<sup>2</sup></b>								
CZB04211	PV8*C16	FC/MC/PC48C	21	1400	41.0	30.2	13.50	11.00
	PV8*C20	FC/MC/PC48C	21	1400	41.0	30.2	13.50	11.00
	P(C,V)9*C16	FC/MC/PC48C	21	1400	41.0	30.2	13.50	11.00
	P(C,V)9*C20	FC/MC/PC48C	21	1400	41.0	30.2	13.50	11.00
	P(C,V)9*D20	FC/MC/PC48D	24	1400	41.0	30.2	13.50	11.00
	PV8*C20	HC60	21	1400	40.5	29.8	13.25	11.00
	P(C,V)9*C20	HC60	21	1400	40.5	29.8	13.25	11.00
	PV8*C16	HD60	21	1400	40.5	29.8	13.25	11.00
	PV8*C20	HD60	21	1400	40.5	29.8	13.25	11.00
	P(C,V)9*C16	HD60	21	1400	40.5	29.8	13.25	11.00
	P(C,V)9*C20	HD60	21	1400	40.5	29.8	13.25	11.00
	P(C,V)9*D20	HD60	24	1400	40.5	29.8	13.25	11.00
CZB04811	P(C,V)9*C20	FC/PC60C	21	1600	48.0	36.1	13.05	11.00
	P(C,V)9*C20	FC/MC/PC60D	21	1600	48.0	36.1	13.05	11.00
	P(C,V)9*D20	FC/MC/PC60D	24	1600	48.0	36.1	13.25	11.00
	PV8*C20	HC60	21	1600	48.0	36.1	13.05	11.00
	P(C,V)9*D20	HC60	24	1600	48.0	36.1	13.25	11.00
	PV8*C20	HD60	21	1600	48.0	36.1	13.05	11.00
	P(C,V)9*D20	HD60	24	1600	48.0	36.1	13.25	11.00
CZB06011	PV8*C20	FC/PC60C	21	1730	55.5	39.7	13.10	11.00
	P(C,V)9*C20	FC/PC60C	21	1620	55.0	39.3	13.05	11.00
	PV8*C20	FC/MC/PC60D	21	1730	55.5	39.7	13.10	11.00
	P(C,V)9*C20	FC/MC/PC60D	21	1620	55.0	39.3	13.05	11.00
	P(C,V)9*D20	FC/MC/PC60D	24	1620	55.0	39.3	13.25	11.00
	PV8*C20	HC60	21	1610	55.0	39.3	13.10	11.00
	P(C,V)9*D20	HC60	24	1610	55.0	39.3	13.10	11.00
	PV8*C20	HD60	21	1610	55.0	39.3	13.10	11.00
	P(C,V)9*D20	HD60	24	1610	55.0	39.3	13.10	11.00
	PV8*C20	MC61D	21	1620	56.5	40.4	13.25	11.00
	P(C,V)9*C20	MC61D	21	1620	56.5	40.4	13.25	11.00
	P(C,V)9*D20	MC61D	24	1620	56.5	40.4	13.25	11.00

1 MC coils available with a factory installed horizontal drain pan. See price pages for specific model number.  
 2 Variable speed furnaces have B.O.D (Blower on Delay) standard.

**ACCESSORIES\***

**Hard Start Kit (024-31994-000, 024-31995-000)** - Provides increased starting torque for areas with low voltage.

**TXV Kits** - 1TV09 series thermal expansion valves precisely meter refrigerant for optimum performance

**Low Ambient Pressure Switch Kit (2LA06700424)** - Allows use of air conditioning at low outdoor ambient temperatures. For use with models containing R-410A refrigerant only.

**Dehumidistat (2HU16700124)** - Provides increased dehumidification when matched with variable speed furnace or air handler.

**ROOM THERMOSTATS** - A wide selection of compatible thermostats are available to provide optimum performance and features for any installation.

1H/1C, manual changeover electronic non-programmable thermostat.

1H/1C, auto/manual changeover, electronic programmable, deluxe 7-day, thermostat.

1H/1C, auto/manual changeover, electronic programmable.

\* For the most current accessory information, refer to the price book or consult factory.

**SOUND POWER RATINGS\***

UNIT MODEL	(dBA)
018	65
024	69
030	69
036	72
042	72
048	72
060	72

\* Rated in accordance with ARI 270-95 Standards.

**COLOR GRILLES**

CHOICE OF SEVERAL COLOR COIL GRILLES TO COMPLIMENT ANY HOME.		
Color Grill	Color Description	
1CP0126	Terra Cotta	018, 024
1CP0130	Terra Cotta	030, 036
1CP0136	Terra Cotta	042, 048, 060
1CP0226	Jet Black	018, 024
1CP0230	Jet Black	030, 036
1CP0236	Jet Black	042, 048, 060
1CP0326	Stone	018, 024
1CP0330	Stone	030, 036
1CP0336	Stone	042, 048, 060
1CP0426	Bermuda	018, 024
1CP0430	Bermuda	030, 036
1CP0436	Bermuda	042, 048, 060
1CP0526	Gunmetal	018, 024
1CP0530	Gunmetal	030, 036
1CP0536	Gunmetal	042, 048, 060
1CP0626	Chocolate	018, 024
1CP0630	Chocolate	030, 036
1CP0636	Chocolate	042, 048, 060

<b>COOLING PERFORMANCE DATA</b>																
<b>OUTDOOR UNIT MODEL NO.</b>		<b>CZB01811</b>														
<b>INDOOR COIL MODEL NO.</b>		<b>FC/MC/PC/UC18</b>														
<b>CONDENSER ENTERING AIR TEMPERATURE</b>	<b>ID CFM</b>	<b>450</b>					<b>600</b>					<b>750</b>				
	<b>ID DB (°F)</b>	80	80	75	80	80	80	80	75	80	80	80	80	75	80	80
	<b>ID WB (°F)</b>	57	62	62	67	72	57	62	62	67	72	57	62	62	67	72
65	T.C.	15.3	17.6	16.6	19.3	22.0	17.2	19.5	18.3	21.3	22.8	19.2	21.4	20.0	23.3	23.5
	S.C.	15.3	13.2	10.7	11.3	9.2	17.2	15.9	12.6	13.4	10.2	19.1	18.6	14.6	15.6	11.2
	K.W.	1.1	1.1	1.1	1.1	1.0	1.1	1.1	1.1	1.1	1.0	1.1	1.1	1.1	1.0	1.1
75	T.C.	14.7	16.9	16.0	18.4	20.6	16.5	18.7	17.6	20.2	21.5	18.4	20.4	19.2	22.0	22.5
	S.C.	14.7	13.0	10.5	10.9	8.7	16.5	15.5	12.4	12.9	9.7	18.3	17.9	14.3	15.0	10.8
	K.W.	1.2	1.2	1.2	1.2	1.2	1.2	1.2	1.2	1.2	1.2	1.2	1.2	1.2	1.2	1.2
85	T.C.	14.1	16.2	15.5	17.5	19.2	15.8	17.8	16.9	19.1	20.3	17.5	19.3	18.3	20.7	21.5
	S.C.	14.0	12.7	10.3	10.4	8.1	15.8	15.0	12.2	12.4	9.2	17.5	17.3	14.0	14.4	10.4
	K.W.	1.4	1.4	1.4	1.4	1.4	1.4	1.4	1.4	1.4	1.4	1.4	1.4	1.4	1.4	1.4
95	T.C.	13.4	15.5	14.9	16.6	17.9	15.1	16.9	16.1	18.0	19.1	16.7	18.3	17.4	19.4	20.4
	S.C.	13.4	12.4	10.1	10.0	7.5	15.0	14.5	11.9	11.9	8.7	16.7	16.6	13.8	13.8	10.0
	K.W.	1.6	1.6	1.6	1.6	1.6	1.6	1.6	1.6	1.6	1.6	1.6	1.6	1.6	1.6	1.5
105	T.C.	12.7	14.6	13.8	15.6	16.8	14.3	15.9	15.0	16.9	17.9	15.8	17.3	16.2	18.1	19.0
	S.C.	12.7	11.8	9.5	9.5	7.1	14.2	13.9	11.3	11.3	8.3	15.7	15.9	13.1	13.1	9.4
	K.W.	1.8	1.8	1.8	1.8	1.8	1.8	1.8	1.8	1.8	1.8	1.8	1.8	1.8	1.8	1.8
115	T.C.	12.0	13.7	12.7	14.6	15.7	13.5	15.0	13.9	15.7	16.6	14.9	16.4	15.1	16.9	17.6
	S.C.	12.0	11.3	8.9	9.0	6.8	13.4	13.2	10.7	10.7	7.8	14.8	15.2	12.4	12.5	8.8
	K.W.	2.1	2.1	2.1	2.0	2.0	2.1	2.1	2.0	2.0	2.0	2.0	2.0	2.0	2.0	2.0
125	T.C.	11.3	12.9	11.7	13.6	14.6	12.7	14.1	12.8	14.6	15.4	14.0	15.4	13.9	15.6	16.2
	S.C.	11.3	10.7	8.3	8.5	6.4	12.6	12.6	10.0	10.2	7.4	13.9	14.6	11.8	11.8	8.3
	K.W.	2.3	2.3	2.3	2.3	2.3	2.3	2.3	2.3	2.3	2.2	2.3	2.3	2.3	2.3	2.2

NOTE: ALL CAPACITIES ARE NET (KBTUH) WITH INDOOR FAN HEAT ALREADY DEDUCTED AT 1250 BTUH/1000 CFM.

### Multipliers for determining the performance with other indoor sections.

NOTE: For dry bulb temperatures different than those listed (between 73-87 F), sensible capacity increases by 1060 BTUH per 1000 CFM per degree above the listed temperature and decreases by 1060 BTUH per 1000 CFM per degree below the listed temperature.

<b>Air Handler</b>	<b>Coil</b>	<b>T.C.</b>	<b>S.C.</b>	<b>KW</b>
MA08B	FC/MC18B	1.00	1.00	1.00
MA08B	FC/MC24B	1.00	1.00	1.00
MA08B	FC/MC30B	1.00	1.00	1.00
MV12B	MC18B	1.00	1.00	0.95
AHP18	–	1.00	1.00	1.00
AHP24	–	1.01	1.01	1.00
AV24	–	1.00	1.00	0.95
F*FP024	–	1.00	1.00	1.00
–	FC/MC/PC/UC24	1.00	1.00	1.00
–	FC/MC/PC/UC30	1.00	1.00	1.00
–	HC18	0.98	0.97	1.00

<b>Variable Speed Furnace</b>	<b>Coil</b>	<b>T.C.</b>	<b>S.C.</b>	<b>KW</b>
PV8*A12	FC/MC/PC24A	1.01	1.00	0.95
PV9*A12	FC/MC/PC24A	1.01	1.00	0.95
PV9*B12	FC/MC/PC24B	1.01	1.00	0.95
PV8*A12	FC/MC/PC30A	1.01	1.00	0.95
PV9*A12	FC/MC/PC30A	1.01	1.00	0.95
PV9*B12	FC/MC/PC30B	1.01	1.00	0.95
PV8*A12	HC18	1.01	1.00	0.95
PV9*A12	HC18	1.01	1.00	0.95

<b>COOLING PERFORMANCE DATA</b>																
<b>OUTDOOR UNIT MODEL NO.</b>		<b>CZB02411</b>														
<b>INDOOR COIL MODEL NO.</b>		<b>FC/MC/PC/UC24</b>														
<b>CONDENSER ENTERING AIR TEMPERATURE</b>	ID CFM	600					800					1000				
	ID DB (°F)	80	80	75	80	80	80	80	75	80	80	80	80	75	80	80
	ID WB (°F)	57	62	62	67	72	57	62	62	67	72	57	62	62	67	72
65	T.C.	19.2	19.4	22.0	23.0	26.2	21.5	21.2	22.1	23.8	26.5	23.8	25.7	22.3	24.6	26.8
	S.C.	18.9	16.4	15.9	15.7	11.9	21.2	20.9	18.1	18.3	13.4	23.5	25.4	20.3	21.0	14.8
	K.W.	1.8	1.9	1.8	1.8	1.8	1.8	1.8	1.8	1.8	1.8	1.8	1.8	1.9	1.8	1.8
75	T.C.	21.5	22.3	20.7	24.9	27.5	23.1	23.5	22.5	25.8	28.5	24.7	24.7	24.3	26.7	29.5
	S.C.	21.2	18.3	14.9	15.5	12.4	22.8	21.3	17.3	17.7	13.8	24.4	24.4	19.8	19.9	15.2
	K.W.	1.6	1.6	1.6	1.6	1.6	1.6	1.6	1.6	1.6	1.6	1.6	1.6	1.6	1.6	1.6
85	T.C.	20.3	20.8	21.4	23.9	26.8	22.3	23.0	22.3	24.8	27.5	24.3	25.2	23.3	25.7	28.2
	S.C.	20.0	17.3	15.4	15.6	12.1	22.0	21.1	17.7	18.0	13.6	23.9	24.9	20.0	20.4	15.0
	K.W.	1.7	1.7	1.7	1.7	1.7	1.7	1.7	1.7	1.7	1.7	1.7	1.7	1.7	1.7	1.7
95	T.C.	18.9	19.6	19.7	22.2	25.0	20.8	21.4	20.6	23.0	25.7	22.6	23.3	21.5	23.8	26.3
	S.C.	18.6	16.5	14.3	14.5	11.5	20.5	19.8	16.5	16.8	12.9	22.3	23.0	18.7	19.1	14.3
	K.W.	2.1	2.1	2.1	2.1	2.1	2.1	2.1	2.1	2.1	2.1	2.1	2.0	2.1	2.0	2.0
105	T.C.	17.4	18.3	18.0	20.4	23.2	19.2	19.8	18.9	21.2	23.8	21.0	21.4	19.7	22.0	24.5
	S.C.	17.2	15.7	13.2	13.4	10.9	18.9	18.4	15.2	15.6	12.2	20.7	21.1	17.3	17.8	13.6
	K.W.	2.4	2.4	2.4	2.4	2.4	2.4	2.4	2.4	2.4	2.4	2.4	2.4	2.4	2.4	2.4
115	T.C.	16.0	17.2	16.4	18.7	21.4	17.7	18.3	17.2	19.4	22.0	19.3	19.5	17.9	20.2	22.7
	S.C.	15.8	15.0	12.1	12.4	10.3	17.4	17.1	14.0	14.4	11.6	19.1	19.2	15.9	16.5	12.8
	K.W.	2.8	2.7	2.7	2.7	2.7	2.7	2.7	2.7	2.7	2.7	2.7	2.7	2.7	2.7	2.7
125	T.C.	14.6	15.9	14.8	17.0	19.6	16.2	16.7	15.5	17.7	20.3	17.7	17.6	16.2	18.4	21.0
	S.C.	14.4	14.2	11.0	11.4	9.7	16.0	15.8	12.8	13.3	10.9	17.5	17.3	14.6	15.2	12.1
	K.W.	3.1	3.1	3.1	3.1	3.1	3.1	3.1	3.1	3.1	3.1	3.1	3.1	3.1	3.1	3.1

NOTE: ALL CAPACITIES ARE NET (KBTUH) WITH INDOOR FAN HEAT ALREADY DEDUCTED AT 1250 BTUH/1000 CFM.

### Multipliers for determining the performance with other indoor sections.

NOTE: For dry bulb temperatures different than those listed (between 73-87 F), sensible capacity increases by 1060 BTUH per 1000 CFM per degree above the listed temperature and decreases by 1060 BTUH per 1000 CFM per degree below the listed temperature.

Air Handler	Coil	T.C.	S.C.	KW
MA08B	FC/MC24B	1.00	1.01	1.00
MA08B	FC/MC30B	1.00	1.01	1.00
MV12B	MC24B	1.00	1.01	0.95
AHP24	–	1.00	1.01	1.00
AV24	–	1.00	1.00	0.95
–	FC/MC/PC/UC30	1.00	1.01	1.00
–	HC30	0.98	0.98	1.00
–	HD24	0.98	0.98	1.00

Variable Speed Furnace	Coil	T.C.	S.C.	KW
PV8*A12	FC/MC/PC24A	1.02	1.02	0.95
PV9*A12	FC/MC/PC24A	1.02	1.02	0.95
P(C,V)9*B12	FC/MC/PC24B	1.02	1.02	0.95
PV8*A12	FC/MC/PC30A	1.02	1.02	0.95
PV9*A12	FC/MC/PC30A	1.02	1.02	0.95
P(C,V)9*B12	FC/MC/PC30B	1.02	1.02	0.95
PV8*A12	HC30	0.99	0.99	0.95
PV9*A12	HC30	0.99	0.99	0.95
PV8*A12	HD24	0.99	0.99	0.95
PV9*A12	HD24	0.99	0.99	0.95

<b>COOLING PERFORMANCE DATA</b>																
<b>OUTDOOR UNIT MODEL NO.</b>		<b>CZB03011</b>														
<b>INDOOR COIL MODEL NO.</b>		<b>FC/MC/PC/UC30</b>														
<b>CONDENSER ENTERING AIR TEMPERATURE</b>	ID CFM	800					1000					1200				
	ID DB (°F)	80	80	75	80	80	80	80	75	80	80	80	80	75	80	80
	ID WB (°F)	57	62	62	67	72	57	62	62	67	72	57	62	62	67	72
65	T.C.	22.5	23.1	25.7	30.8	34.9	25.0	25.2	26.9	30.4	34.6	27.5	27.4	28.0	30.1	34.3
	S.C.	23.0	19.2	18.2	21.2	17.3	25.7	23.9	20.8	22.5	18.1	28.3	28.5	23.4	23.9	19.0
	K.W.	2.3	5.2	2.3	2.4	2.4	2.3	3.7	2.3	2.4	2.4	2.3	2.3	2.3	2.4	2.4
75	T.C.	25.8	28.5	29.0	31.5	35.5	28.0	29.8	29.9	32.5	36.7	30.3	31.1	30.8	33.6	37.9
	S.C.	26.7	24.6	21.1	20.6	17.0	29.0	26.9	23.2	22.7	18.5	31.3	29.2	25.3	24.9	20.0
	K.W.	2.0	2.0	2.0	2.0	2.1	2.0	2.0	2.0	2.0	2.1	2.0	2.0	2.0	2.0	2.1
85	T.C.	24.2	31.7	27.4	31.2	35.2	26.5	30.5	28.4	31.5	35.6	28.9	29.3	29.4	31.8	36.1
	S.C.	24.9	21.9	19.7	20.9	17.2	27.3	25.4	22.0	22.6	18.3	29.8	28.9	24.3	24.4	19.5
	K.W.	2.2	3.6	2.1	2.2	2.3	2.1	2.9	2.1	2.2	2.3	2.1	2.1	2.1	2.2	2.3
95	T.C.	23.3	21.5	25.9	28.6	32.3	25.5	24.6	26.8	29.4	33.0	27.6	27.7	27.7	30.2	33.8
	S.C.	24.0	22.2	19.3	19.5	15.9	26.3	25.1	21.5	21.5	17.3	28.5	28.0	23.7	23.5	18.8
	K.W.	2.5	3.6	2.5	2.6	2.6	2.5	3.1	2.5	2.6	2.6	2.5	2.5	2.5	2.6	2.6
105	T.C.	22.4	11.2	24.3	26.1	29.5	24.4	23.7	25.2	27.3	30.4	26.3	26.2	26.0	28.5	31.4
	S.C.	23.2	22.6	19.0	18.2	14.6	25.2	24.8	21.0	20.4	16.3	27.2	27.1	23.0	22.5	18.1
	K.W.	2.9	3.6	2.9	3.0	3.0	2.9	3.2	2.9	3.0	3.0	2.9	2.9	2.9	3.0	3.0
115	T.C.	21.6	21.9	22.9	23.6	26.7	23.4	23.5	23.6	25.3	27.9	25.1	24.7	24.4	27.0	29.2
	S.C.	22.4	22.9	18.7	16.9	13.3	24.2	24.5	20.5	19.3	15.3	26.0	26.2	22.3	21.6	17.4
	K.W.	3.2	3.6	3.2	3.3	3.4	3.2	3.4	3.2	3.3	3.4	3.3	3.2	3.2	3.4	3.4
125	T.C.	20.8	22.2	21.4	21.1	23.9	22.3	23.2	22.1	23.2	25.4	23.9	23.2	22.7	25.4	26.9
	S.C.	21.6	23.3	18.4	15.6	12.1	23.1	24.3	20.0	18.2	14.4	24.7	25.3	21.7	20.7	16.7
	K.W.	3.5	3.6	3.6	3.7	3.7	3.6	3.6	3.6	3.7	3.7	3.6	3.6	3.6	3.7	3.8

NOTE: ALL CAPACITIES ARE NET (KBTUH) WITH INDOOR FAN HEAT ALREADY DEDUCTED AT 1250 BTUH/1000 CFM.

**Multipliers for determining the performance with other indoor sections.**

NOTE: For dry bulb temperatures different than those listed (between 73-87 F), sensible capacity increases by 1060 BTUH per 1000 CFM per degree above the listed temperature and decreases by 1060 BTUH per 1000 CFM per degree below the listed temperature.

Air Handler	Coil	T.C.	S.C.	KW
MA12B	FC/MC30B	1.01	1.00	1.00
MA12B	FC/MC36B	1.02	1.01	1.00
MV12B	MC36B	1.04	1.03	0.95
AHP36	-	1.02	1.01	1.00
AHP30	-	1.02	1.01	1.00
AV36	-	1.02	1.01	0.95
F*FP036	-	1.04	1.03	1.00
-	FC/MC/PC/UC36	1.02	1.01	1.00
-	HC36	1.02	1.01	1.00
-	HD36	1.02	1.01	1.00

Variable Speed Furnace	Coil	T.C.	S.C.	KW
PV8*A12	FC/MC/PC30A	1.02	1.01	1.00
PV9*A12	FC/MC/PC30A	1.02	1.01	1.00
PV8*B16	FC/MC/PC30B	1.02	1.01	1.00
P(C,V)9*B12	FC/MC/PC30B	1.02	1.01	1.00
PV8*A12	FC/MC/PC36A	1.04	1.03	0.95
P(C,V)9*B12	FC/MC/PC36A	1.04	1.03	0.95
PV8*B16	FC/MC/PC36B	1.04	1.03	0.95
P(C,V)9*B12	FC/MC/PC36B	1.04	1.03	0.95
PV8*C16	FC/MC/PC36C	1.04	1.03	0.95
P(C,V)9*C16	FC/MC/PC36C	1.04	1.03	0.95
PV8*B16	HC36	1.02	1.02	0.95
P(C,V)9*B12	HC36	1.02	1.02	0.95
PV8*C16	HD36	1.02	1.02	0.95
P(C,V)9*C16	HD36	1.02	1.02	0.95

<b>COOLING PERFORMANCE DATA</b>																
<b>OUTDOOR UNIT MODEL NO.</b>		<b>CZB03611</b>														
<b>INDOOR COIL MODEL NO.</b>		<b>FC/MC/PC35</b>														
<b>CONDENSER ENTERING AIR TEMPERATURE</b>	ID CFM	1050					1200					1350				
	ID DB (°F)	80	80	75	80	80	80	80	75	80	80	80	80	75	80	80
	ID WB (°F)	57	62	62	67	72	57	62	62	67	72	57	62	62	67	72
65	T.C.	32.7	33.4	31.9	34.6	38.3	34.4	34.2	32.1	35.6	38.5	36.1	34.9	32.4	36.6	38.7
	S.C.	30.7	30.6	24.4	24.3	19.2	31.9	32.4	26.2	33.4	20.7	33.1	34.1	28.0	42.5	22.1
	K.W.	2.9	2.9	2.9	2.9	2.9	2.9	2.9	2.9	2.9	2.9	2.9	2.9	2.9	2.9	2.9
75	T.C.	35.5	36.2	35.4	38.9	41.7	36.8	37.3	36.0	39.8	42.2	38.1	38.4	36.6	40.6	42.6
	S.C.	33.7	31.3	26.3	26.3	21.1	35.1	33.5	28.0	20.8	22.1	36.6	35.6	29.8	15.4	23.2
	K.W.	2.5	2.5	2.5	2.5	2.5	2.5	2.5	2.5	2.5	2.5	2.5	2.5	2.5	2.5	2.5
85	T.C.	34.1	34.8	33.6	36.7	40.0	35.6	35.7	34.0	37.7	40.3	37.1	36.6	34.5	38.6	40.7
	S.C.	32.2	31.0	25.3	25.3	20.1	33.5	32.9	27.1	27.1	21.4	34.8	34.9	28.9	29.0	22.7
	K.W.	2.7	2.7	2.7	2.7	2.7	2.7	2.7	2.7	2.7	2.7	2.7	2.7	2.7	2.7	2.7
95	T.C.	32.4	32.9	31.6	34.8	37.5	33.8	33.8	32.0	35.6	37.8	35.1	34.7	32.4	36.4	38.2
	S.C.	30.5	29.7	24.4	24.6	19.4	31.8	31.4	26.1	26.3	20.6	33.0	33.1	27.8	28.0	21.8
	K.W.	3.2	3.2	3.2	3.2	3.2	3.2	3.2	3.2	3.2	3.2	3.2	3.2	3.2	3.2	3.2
105	T.C.	30.7	31.0	29.5	32.9	35.1	31.9	31.9	30.0	33.5	35.4	33.1	32.8	30.4	34.2	35.6
	S.C.	28.9	28.3	23.5	23.8	18.6	30.0	29.8	25.0	25.5	19.8	31.1	31.2	26.6	27.1	21.0
	K.W.	3.6	3.6	3.6	3.6	3.6	3.6	3.6	3.6	3.6	3.6	3.6	3.6	3.6	3.6	3.6
115	T.C.	29.0	29.1	27.6	31.0	32.7	30.1	30.0	28.0	31.5	33.0	31.2	30.9	28.4	32.1	33.2
	S.C.	27.3	27.0	22.6	23.0	17.8	28.3	28.2	24.0	24.6	19.0	29.3	29.5	25.5	26.2	20.2
	K.W.	4.1	4.1	4.1	4.1	4.0	4.1	4.1	4.1	4.0	4.0	4.1	4.1	4.1	4.0	4.1
125	T.C.	27.4	27.2	25.6	29.1	30.3	28.3	28.2	26.0	29.5	30.5	29.3	29.1	26.4	29.9	30.8
	S.C.	25.7	25.7	21.7	22.3	17.1	26.6	26.7	23.0	23.8	18.2	27.5	27.7	24.4	25.3	19.3
	K.W.	4.5	4.5	4.5	4.5	4.5	4.5	4.5	4.5	4.5	4.5	4.5	4.5	4.5	4.5	4.5

NOTE: ALL CAPACITIES ARE NET (KBTUH) WITH INDOOR FAN HEAT ALREADY DEDUCTED AT 1250 BTUH/1000 CFM.

### Multipliers for determining the performance with other indoor sections.

NOTE: For dry bulb temperatures different than those listed (between 73-87 F), sensible capacity increases by 1060 BTUH per 1000 CFM per degree above the listed temperature and decreases by 1060 BTUH per 1000 CFM per degree below the listed temperature.

Air Handler	Coil	T.C.	S.C.	KW
MA12B	FC/MC36B	1.00	1.00	1.00
MA12B	FC/MC42B	1.01	1.00	1.00
MV12B	MC36B	1.01	1.00	1.00
MV12B	MC42B	1.01	1.01	1.00
AHP36	—	1.01	1.00	1.00
AHP42	—	1.01	1.00	1.00
AV36	—	1.01	1.00	0.95
F*FP036	—	1.01	1.01	1.00
F*FP048	—	1.02	1.01	1.00
—	FC/MC/PC/UC36	1.00	1.00	1.00
—	FC/MC/PC/UC42	1.01	1.00	1.00
—	HC36	1.01	1.00	1.00
—	HD36	1.00	1.00	1.00

Variable Speed Furnace	Coil	T.C.	S.C.	KW
PV8*A12	FC/MC/PC36A	0.98	0.98	1.00
PV9*A12	FC/MC/PC36A	1.00	1.00	1.00
PV8*B16	FC/MC/PC36B	1.01	1.00	1.00
P(C,V)9*B12	FC/MC/PC36B	1.00	1.00	1.00
PV8*C16	FC/MC/PC36C	1.01	1.00	1.00
PV8*C20	FC/MC/PC36C	1.01	1.00	1.00
P(C,V)9*C16	FC/MC/PC36C	1.00	1.00	1.00
P(C,V)9*C20	FC/MC/PC36C	1.00	1.00	1.00
PV8*B16	FC/MC/PC42B	1.03	1.03	1.00
P(C,V)9*B12	FC/MC/PC42B	1.01	1.01	1.00
PV8*C16	FC/MC/PC42C	1.03	1.03	1.00
PV8*C20	FC/MC/PC42C	1.03	1.03	1.00
PV8*B16	HC36	1.01	1.00	1.00
P(C,V)9*B12	HC36	1.01	1.00	1.00
PV8*C16	HD36	1.01	1.00	1.00
P(C,V)9*C16	HD36	1.01	1.00	1.00
P(C,V)9*C20	HD36	1.01	1.00	1.00

<b>COOLING PERFORMANCE DATA</b>																	
<b>OUTDOOR UNIT MODEL NO.</b>		<b>CZB04211</b>															
<b>INDOOR COIL MODEL NO.</b>		<b>FC/MC/PC/UC48</b>															
<b>CONDENSER ENTERING AIR TEMPERATURE</b>	<b>ID CFM</b>	<b>1200</b>					<b>1400</b>					<b>1600</b>					
	<b>ID DB (°F)</b>	80	80	75	80	80	80	80	75	80	80	80	80	80	75	80	80
	<b>ID WB (°F)</b>	57	62	62	67	72	57	62	62	67	72	57	62	62	67	72	57
65	T.C.	36.0	38.4	36.8	40.5	45.9	38.2	39.0	38.3	41.8	46.9	40.3	39.5	39.7	43.2	47.9	
	S.C.	35.9	34.7	29.1	28.6	22.1	38.1	37.8	31.5	30.8	23.4	40.3	40.9	33.9	33.1	24.8	
	K.W.	3.3	3.3	3.3	3.3	3.4	3.3	3.3	3.3	3.3	3.4	3.3	3.3	3.3	3.3	3.4	
75	T.C.	38.9	40.1	40.9	43.9	49.3	40.7	41.2	42.0	45.3	50.7	42.6	42.3	43.1	46.8	52.0	
	S.C.	38.9	34.9	30.1	29.4	23.4	40.8	37.8	32.5	31.7	24.8	42.6	40.8	34.9	34.1	26.3	
	K.W.	2.9	2.9	2.9	2.9	2.9	2.9	2.9	2.9	2.9	2.9	2.9	2.9	2.9	2.9	2.9	
85	T.C.	37.5	39.3	38.9	42.2	47.6	39.5	40.1	40.1	43.6	48.8	41.4	40.9	41.4	45.0	49.9	
	S.C.	37.4	34.8	29.6	29.0	22.8	39.4	37.8	32.0	31.3	24.1	41.4	40.8	34.4	33.6	25.5	
	K.W.	3.1	3.1	3.1	3.1	3.1	3.1	3.1	3.1	3.1	3.1	3.1	3.1	3.1	3.1	3.1	
95	T.C.	35.5	37.0	36.7	39.9	44.8	37.2	37.9	37.7	41.0	45.8	39.0	38.8	38.8	42.1	46.8	
	S.C.	35.4	33.6	28.6	27.9	21.8	37.2	36.3	30.9	30.2	23.2	38.9	38.9	33.2	32.5	24.5	
	K.W.	3.6	3.6	3.6	3.6	3.7	3.6	3.6	3.6	3.6	3.7	3.6	3.6	3.6	3.6	3.7	
105	T.C.	33.5	34.7	34.5	37.5	42.0	35.0	35.7	35.3	38.4	42.8	36.5	36.7	36.2	39.3	43.6	
	S.C.	33.4	32.5	27.5	26.9	20.8	34.9	34.8	29.7	29.1	22.2	36.5	37.1	31.9	31.3	23.6	
	K.W.	4.1	4.1	4.1	4.2	4.2	4.1	4.1	4.1	4.2	4.2	4.1	4.1	4.1	4.2	4.2	
115	T.C.	31.6	32.5	32.3	35.3	39.2	32.9	33.6	33.0	35.9	39.9	34.2	34.7	33.7	36.6	40.5	
	S.C.	31.5	31.3	26.5	25.9	19.9	32.8	33.3	28.6	28.1	21.2	34.0	35.3	30.7	30.3	22.6	
	K.W.	4.6	4.6	4.6	4.7	4.7	4.6	4.6	4.6	4.7	4.7	4.7	4.7	4.6	4.7	4.7	
125	T.C.	29.7	30.3	30.2	33.0	36.5	30.7	31.8	30.7	33.4	37.0	31.8	32.7	31.2	33.8	37.5	
	S.C.	29.6	30.2	25.5	24.8	18.9	30.6	31.8	27.5	27.0	20.3	31.6	33.5	29.5	29.2	21.7	
	K.W.	5.2	5.1	5.2	5.2	5.2	5.2	5.2	5.2	5.2	5.2	5.2	5.2	5.2	5.2	5.2	

NOTE: ALL CAPACITIES ARE NET (KBTUH) WITH INDOOR FAN HEAT ALREADY DEDUCTED AT 1250 BTUH/1000 CFM.

### Multipliers for determining the performance with other indoor sections.

NOTE: For dry bulb temperatures different than those listed (between 73-87 F), sensible capacity increases by 1060 BTUH per 1000 CFM per degree above the listed temperature and decreases by 1060 BTUH per 1000 CFM per degree below the listed temperature.

<b>Air Handler</b>	<b>Coil</b>	<b>T.C.</b>	<b>S.C.</b>	<b>KW</b>
MA16C	FC/MC48C	1.00	1.00	1.00
MA14D	FC/MC48D	1.00	1.00	1.00
MV16C	MC48C	1.01	1.00	1.00
MV20D	MC48D	1.01	1.00	1.00
AHP/SHP48	–	1.01	1.00	1.00
AHP/SHP60	–	1.01	1.00	1.00
AV/SV48	–	1.01	1.00	0.95
F*FP048	–	1.00	1.00	1.00
–	HC60	0.98	0.98	1.00
–	HD60	0.97	0.97	1.00

<b>Variable Speed Furnace</b>	<b>Coil</b>	<b>T.C.</b>	<b>S.C.</b>	<b>KW</b>
PV8*C16	FC/MC/PC48C	1.00	1.00	1.00
PV8*C20	FC/MC/PC48C	1.00	1.00	1.00
P(C,V)9*C16	FC/MC/PC48C	1.00	1.00	1.00
P(C,V)9*C20	FC/MC/PC48C	1.00	1.00	1.00
P(C,V)9*D20	FC/MC/PC48D	1.00	1.00	1.00
PV8*C20	HC60	0.98	0.98	1.00
P(C,V)9*C20	HC60	0.98	0.98	1.00
PV8*C16	HD60	0.98	0.98	1.00
PV8*C20	HD60	0.98	0.98	1.00
P(C,V)9*C16	HD60	0.98	0.98	1.00
P(C,V)9*C20	HD60	0.98	0.98	1.00
P(C,V)9*D20	HD60	0.98	0.98	1.00

<b>COOLING PERFORMANCE DATA</b>																
<b>OUTDOOR UNIT MODEL NO.</b>		<b>CZB04811</b>														
<b>INDOOR COIL MODEL NO.</b>		<b>FC/MC/PC/UC60</b>														
<b>CONDENSER ENTERING AIR TEMPERATURE</b>	ID CFM	1400					1600					1800				
	ID DB (°F)	80	80	75	80	80	80	80	75	80	80	80	80	75	80	80
	ID WB (°F)	57	62	62	67	72	57	62	62	67	72	57	62	62	67	72
65	T.C.	43.3	45.9	42.8	48.1	55.4	45.5	46.7	43.4	49.0	54.8	47.7	47.5	44.0	49.9	54.3
	S.C.	39.3	43.5	33.0	34.3	27.3	41.5	44.4	35.4	36.7	28.5	43.7	45.3	37.7	39.1	29.7
	K.W.	3.9	3.9	3.9	3.9	3.9	3.9	3.9	3.9	4.0	3.9	3.9	3.9	4.0	4.0	3.9
75	T.C.	48.0	49.5	47.8	53.7	57.7	50.0	50.7	48.6	54.2	58.2	52.1	51.9	49.3	54.8	58.7
	S.C.	43.5	42.5	35.8	36.2	28.6	45.2	45.3	38.2	38.6	30.2	46.9	48.2	40.5	41.0	31.8
	K.W.	3.3	3.4	3.3	3.4	3.4	3.3	3.4	3.3	3.4	3.4	3.3	3.4	3.3	3.4	3.4
85	T.C.	45.6	47.7	45.3	50.9	56.6	47.8	48.7	46.0	51.6	56.5	49.9	49.7	46.7	52.3	56.5
	S.C.	41.4	43.0	34.4	35.3	27.9	43.3	44.9	36.8	37.7	29.3	45.3	46.8	39.1	40.1	30.7
	K.W.	3.6	3.6	3.6	3.6	3.6	3.6	3.6	3.6	3.7	3.6	3.6	3.6	3.6	3.7	3.6
95	T.C.	43.3	44.9	42.4	47.9	52.4	45.2	45.9	43.1	48.5	52.4	47.0	46.9	43.8	49.1	52.4
	S.C.	39.3	40.5	33.3	34.2	26.7	41.0	42.3	35.4	36.5	28.1	42.7	44.2	37.5	38.8	29.5
	K.W.	4.2	4.2	4.1	4.2	4.2	4.2	4.2	4.2	4.2	4.2	4.2	4.2	4.2	4.3	4.2
105	T.C.	41.0	42.0	39.5	44.8	48.2	42.6	43.1	40.2	45.4	48.2	44.1	44.1	40.8	45.9	48.3
	S.C.	37.1	38.1	32.1	33.0	25.5	38.6	39.8	34.0	35.3	26.9	40.1	41.6	35.9	37.6	28.3
	K.W.	4.7	4.8	4.7	4.8	4.8	4.7	4.7	4.7	4.8	4.8	4.7	4.7	4.7	4.8	4.8
115	T.C.	38.8	39.3	36.7	41.9	44.1	40.0	40.3	37.3	42.3	44.2	41.2	41.4	38.0	42.8	44.3
	S.C.	35.0	35.7	31.0	32.0	24.2	36.3	37.4	32.7	34.2	25.7	37.5	39.1	34.4	36.5	27.2
	K.W.	5.2	5.3	5.2	5.3	5.4	5.2	5.3	5.2	5.3	5.4	5.2	5.3	5.3	5.4	5.4
125	T.C.	36.6	36.5	33.9	38.9	40.0	37.5	37.6	34.5	39.3	40.2	38.4	38.6	35.1	39.7	40.3
	S.C.	33.0	33.3	29.8	30.9	23.0	34.0	34.9	31.3	33.1	24.5	35.0	36.5	32.8	35.3	26.0
	K.W.	5.8	5.8	5.8	5.9	5.9	5.8	5.8	5.8	5.9	5.9	5.8	5.8	5.8	5.9	5.9

NOTE: ALL CAPACITIES ARE NET (KBTUH) WITH INDOOR FAN HEAT ALREADY DEDUCTED AT 1250 BTUH/1000 CFM.

### Multipliers for determining the performance with other indoor sections.

NOTE: For dry bulb temperatures different than those listed (between 73-87 F), sensible capacity increases by 1060 BTUH per 1000 CFM per degree above the listed temperature and decreases by 1060 BTUH per 1000 CFM per degree below the listed temperature.

Air Handler	Coil	T.C.	S.C.	KW
MA20D	FC/MC60D	1.00	1.00	1.00
MA16C	FC60C	1.00	1.00	1.00
MV20D	MC60D	1.01	1.00	1.00
AHP/SHP48	—	1.01	1.00	1.00
AHP/SHP60	—	1.01	1.00	1.00
AV/SV48	—	1.00	1.00	0.98
AV/SV60	—	1.00	1.00	0.95
F*FV060	—	1.02	1.01	1.00
—	HC60	1.00	1.00	1.00
—	HD60	1.00	1.00	1.00

Variable Speed Furnace	Coil	T.C.	S.C.	KW
P(C,V)9*D20	FC/MC/PC60D	1.01	1.00	1.00
P(C,V)9*C20	FC/PC60C	1.01	1.00	1.00
PV8*C20	HC60	1.01	1.00	1.00
P(C,V)9*D20	HC60	1.01	1.00	1.00
PV8*C20	HD60	1.01	1.00	1.00
P(C,V)9*D20	HD60	1.01	1.00	1.00
P(C,V)9*C20	MC60D	1.01	1.00	1.00

<b>COOLING PERFORMANCE DATA</b>																
<b>OUTDOOR UNIT MODEL NO.</b>		<b>CZB06011</b>														
<b>INDOOR COIL MODEL NO.</b>		<b>FC/MC/PC/UC60</b>														
<b>CONDENSER ENTERING AIR TEMPERATURE</b>	ID CFM	1600					1800					2000				
	ID DB (°F)	80	80	75	80	80	80	80	75	80	80	80	80	75	80	80
	ID WB (°F)	57	62	62	67	72	57	62	62	67	72	57	62	62	67	72
65	T.C.	51.8	52.8	50.6	57.9	61.8	52.8	54.2	52.5	58.6	63.1	53.8	55.6	54.3	59.3	64.4
	S.C.	39.4	48.8	44.1	39.1	30.3	42.1	52.3	44.	41.1	31.7	44.7	55.9	48.5	43.2	33.1
	K.W.	4.6	4.6	4.5	4.7	4.8	4.6	4.6	4.6	4.7	4.8	4.6	4.7	4.6	4.8	4.8
75	T.C.	55.1	56.9	53.6	61.5	65.7	56.1	58.3	55.4	62.6	66.5	57.0	59.7	57.3	63.7	67.2
	S.C.	41.1	50.2	44.4	40.8	31.3	43.4	53.1	46.0	43.1	32.6	45.6	56.0	49.3	45.5	33.9
	K.W.	4.0	4.0	3.9	4.0	4.1	4.0	4.0	3.9	4.0	4.1	4.0	4.0	3.9	4.0	4.1
85	T.C.	53.5	54.8	52.1	59.7	63.8	54.5	56.2	54.0	60.6	64.8	55.4	57.7	55.8	61.5	65.8
	S.C.	40.3	49.5	44.0	39.9	30.8	42.7	52.7	45.9	42.1	32.2	45.2	55.9	48.7	44.3	33.5
	K.W.	4.3	4.3	4.2	4.4	4.4	4.3	4.3	4.3	4.4	4.5	4.3	4.3	4.3	4.4	4.5
95	T.C.	49.9	51.3	49.3	56.1	59.7	50.8	52.6	51.0	57.0	60.6	51.6	53.9	52.7	57.9	61.5
	S.C.	38.6	47.0	43.1	38.5	29.3	40.8	49.9	44.1	40.8	30.6	43.1	52.8	48.4	43.1	31.9
	K.W.	5.0	5.0	4.9	5.1	5.2	5.0	5.0	5.0	5.1	5.2	5.0	5.0	5.0	5.1	5.2
105	T.C.	46.4	47.7	46.5	52.4	55.6	47.1	48.9	48.1	53.4	56.4	47.8	50.1	49.6	54.4	57.2
	S.C.	36.9	44.6	40.7	37.2	27.8	39.0	47.1	41.7	39.5	29.1	41.0	49.7	43.6	41.8	30.4
	K.W.	5.7	5.7	5.7	5.8	5.9	5.7	5.7	5.7	5.8	5.9	5.7	5.7	5.7	5.8	5.9
115	T.C.	42.9	44.3	43.8	48.9	51.7	43.5	45.3	45.2	49.9	52.3	44.2	46.4	46.6	50.9	52.9
	S.C.	35.2	42.2	37.9	35.8	26.4	37.1	44.4	39.0	38.2	27.6	39.0	46.6	40.2	40.5	28.8
	K.W.	6.4	6.4	6.3	6.5	6.6	6.4	6.4	6.4	6.5	6.6	6.4	6.4	6.4	6.5	6.6
125	T.C.	39.5	40.8	41.1	45.4	47.7	40.0	41.8	42.3	46.4	48.2	40.5	42.7	43.5	47.5	48.7
	S.C.	33.6	39.9	36.0	34.5	25.0	35.3	41.7	35.4	36.9	26.1	37.0	43.6	36.6	39.3	27.3
	K.W.	7.1	7.1	7.0	7.1	7.3	7.1	7.1	7.1	7.2	7.3	7.1	7.1	7.1	7.2	7.3

NOTE: ALL CAPACITIES ARE NET (KBTUH) WITH INDOOR FAN HEAT ALREADY DEDUCTED AT 1250 BTUH/1000 CFM.

**Multipliers for determining the performance with other indoor sections.**

NOTE: For dry bulb temperatures different than those listed (between 73-87 F), sensible capacity increases by 1060 BTUH per 1000 CFM per degree above the listed temperature and decreases by 1060 BTUH per 1000 CFM per degree below the listed temperature.

Air Handler	Coil	T.C.	S.C.	KW
MA20D	FC/MC60D	1.00	1.00	1.00
MA20D	MC61	1.00	1.00	1.00
MV20D	MC60D	1.00	1.00	1.00
MV20D	MC61D	1.03	1.03	1.00
AHP/SHP60	-	1.00	1.00	1.00
AV/SV60	-	1.02	1.02	0.98
F*FV060	-	1.02	1.02	1.00
-	HC60	1.00	1.00	1.00
-	HD60	1.00	1.00	1.00
-	MC61	1.00	1.00	1.00

Variable Speed Furnace	Coil	T.C.	S.C.	KW
P(C,V)9*D20	FC/MC/PC60D	0.99	0.98	1.00
PV8*C20	FC/PC60C	1.00	1.00	1.00
P(C,V)9*C20	FC/PC60C	0.99	0.98	1.00
PV8*C20	HC60	0.99	0.98	1.00
P(C,V)9*D20	HC60	0.99	0.98	1.00
PV8*C20	HD60	0.99	0.98	1.00
P(C,V)9*D20	HD60	0.99	0.98	1.00
PV8*C20	MC60D	1.00	1.00	1.00
P(C,V)9*C20	MC60D	0.99	0.98	1.00
PV8*C20	MC61D	1.01	1.01	1.00
P(C,V)9*C20	MC61D	1.01	1.01	1.00
P(C,V)9*D20	MC61D	1.01	1.01	1.00

# NOTES

Subject to change without notice. Printed in U.S.A.  
Copyright © by Unitary Products Group. 2007. All rights reserved.

246723-YTG-L-0807  
Supersedes: 246723-YTG-K-0507

---

**Unitary  
Products  
Group**

**5005  
York  
Drive**

**Norman  
OK  
73069**