



YORK®

Heating and Air Conditioning

TECHNICAL GUIDE

AFFINITY

R-410A SPLIT-SYSTEM AIR CONDITIONERS

15 SEER

MODELS:

CZE024THRU 060

(2 THRU 5 NOMINAL TONS)



Due to continuous product improvement, specifications are subject to change without notice.

Visit us on the web at www.york.com for the most up-to-date technical information.

Additional rating information can be found at www.ariprimeret.org.

DESCRIPTION

The CZE Series condensing unit is the outdoor part of a versatile air conditioning system. It is designed to be custom matched with one of our complete line of evaporator sections, each designed to serve a specific function. Matching air handlers are available for upflow, downflow, and horizontal left or right application to provide a complete system. Electric heaters are available if required. Add-on coils are available for use with upflow, downflow, or horizontal furnaces. Field installed accessories are available as needed.

WARRANTY

5-year limited parts warranty.

10-year limited compressor warranty.

Premium System Warranty - Limited lifetime compressor and 10-year parts when matched with an approved York Affinity furnace or UPG air handler and coil.

FEATURES

- **Superior Coil Protection** – A stamped decorative metal coil guard completely protects coil from debris and other large damaging material while a polymer mesh further protects the coil against smaller particles.
- **Isolated Compressor Compartment** – A molded composite bulkhead isolates the compressor from the rest of the unit reducing sound and vibration.
- **Protected Compressors** – Each compressor is protected against abnormal pressures by an internal pressure relief valve and factory installed high and low pressure controls. Additional protection against moisture and debris is provided by factory installed liquid line filter driers.
- **Environmentally Friendly Refrigerant** – Next generation refrigerant R-410A delivers environmentally friendly performance with zero ozone depletion.
- **Durable Finish** – Automotive quality finish provides the ultimate protection from harmful U.V. rays and rust creep ensuring long-lasting high quality appearance. A powder-paint topcoat is applied over a baked-on primer, using a galvanized, zinc coated steel base material. The result is a finish that has been proven in testing to provide 33% greater durability than conventional powder-coat finishes.
- **Lower Installed Cost** – Designed to provide enhanced installability by featuring a slide-down control compartment and angled service valves to reduce overall installation time and cost.
- **Low Operating Sound Levels** – A fan design boasting technology adapted from aeronautic and defense engineering provides for whisper quiet operation by allowing airflow to flow smoothly and efficiently across the fan tips.
- **Filter-Drier** – A factory installed, solid core liquid line filter-drier filters harmful debris and moisture from the system.
- **Easy Service Access** – A full end, full service, access panel with handle makes for easy entry to internal components.
- **Composite Base** - Strong and durable composite base pan resists rust and corrosion while it helps reduce vibrations and noise.
- **Quiet drive system** - Features combination of swept-wing fan, composite base pan, isolated compressor compartment and two-stage compressor to reduce overall sound to a mere whisper.
- **Low RPM fan motor** - Helps to reduce airflow noise.

Certified in accordance with the Unitary Small Equipment certification program, which is based on ARI Standard 210/240.

PHYSICAL AND ELECTRICAL DATA

MODEL		CZE02411	CZE03611	CZE04811	CZE06011
Unit Supply Voltage		208-230V, 1 ϕ , 60Hz			
Normal Voltage Range ¹		187 to 252			
Minimum Circuit Ampacity		13.3	22.3	27.9	33.5
Max. Overcurrent Device Amps ²		20	35	45	50
Min. Overcurrent Device Amps ³		15	25	30	35
Compressor Type		Scroll	Scroll	Scroll	Scroll
Compressor Amps	Rated Load	10.3	16.7	21.2	25.6
	Locked Rotor	52	82	96	118
Crankcase Heater		No	No	No	No
Fan Motor Amps	Rated Load	0.5	1.5	1.5	1.5
Fan Diameter Inches		22	22	22	22
Fan Motor	Rated HP	1/15	1/4	1/4	1/4
	Nominal RPM	850	850	850	850
	Nominal CFM	2,000	3,450	3,250	3,150
Coil	Face Area Sq. Ft.	17.15	20.58	20.58	20.58
	Rows Deep	1	1	2	2
	Fins / Inch	22	22	22	22
Liquid Line Set OD (Field Installed)		3/8	3/8	3/8	3/8
Vapor Line Set OD (Field Installed)		3/4	3/4	7/8	1-1/8
Unit Charge (Lbs. - Oz.) ⁴		7 - 5	8 - 4	14 - 2	13 - 9
Charge Per Foot, Oz.		0.62	0.62	0.67	0.75
Operating Weight Lbs.		195	210	260	270

- 1 Rated in accordance with ARI Standard 110, utilization range "A".
- 2 Dual element fuses or HACR circuit breaker. Maximum allowable overcurrent protection.
- 3 Dual element fuses or HACR circuit breaker. Minimum recommended overcurrent protection.
- 4 The Unit Charge is correct for the outdoor unit, matched indoor coil and 15 feet of refrigerant tubing. For tubing lengths other than 15 feet, add or subtract the amount of refrigerant, using the difference in length multiplied by the per foot value.

All dimensions are in inches. They are subject to change without notice. Certified dimensions will be provided upon request.

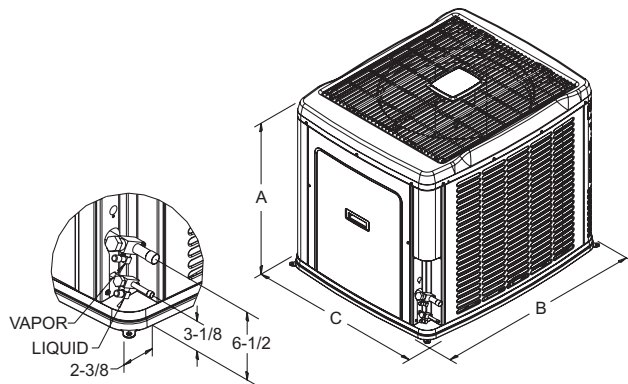

Unit Model	Dimensions (Inches)			Refrigerant Connection Service Valve Size	
	A	B	C	Liquid	Vapor
024	33-1/2	37	31	3/8"	3/4"
036	39-1/2	37	31		7/8"
048	39-1/2	37	31		7/8" *
060	39-1/2	37	31		

* Expander fitting required for 1-1/8" line set.

Additional R-410A Charge / TXV Size for Various Matched Systems				
Outdoor Unit	CZE02411	CZE03611	CZE04811	CZE06011
Approved System Thermal Expansion Valve ¹	1TVM902 1TVM4A1	1TVM902 1TVM4A1	1TVM905	1TVM905
Factory Charge, lbs-oz	7 - 5	8 - 4	14 - 2	13 - 9
Indoor Coil²	TXV Kit³ - Additional Charge, Oz			
FC/MC/PC24B	2	-	-	-
FC/MC/PC30A	5	-	-	-
FC/MC/PC30B	5	-	-	-
FC/MC/PC36A	8	-	-	-
FC/MC/PC36B	8	-	-	-
FC/MC/PC35B	-	8	-	-
FC/MC/PC35C	-	8	-	-
FC/MC/PC42B	-	8	-	-
FC/MC/PC42C	-	8	-	-
FC/MC/PC48C	-	11	-	-
FC/MC/PC48D	-	11	-	-
FC/PC60C	-	-	9	9
FC/MC/PC60D	-	-	9	9
MC61D	-	-	9	9
FC/MC62D	-	-	9	9
HC36B	11	-	-	-
HC42	-	11	-	-
HC60	-	-	9	9
HD36	9	-	-	-
HD48	-	10	-	-
HD60	-	-	9	9
AV24	0	-	-	-
AV36	4	-	-	-
AV/SV48	-	17	9	-
AV/SV60	-	-	9	9
F*FV060	-	-	9	9
F*FV060H06T2C	-	-	9	9

FOOTNOTES:

- 1 Systems matched with furnace or air handlers not equipped with blower-off delays may require blower Time Delay Kit 2FD06700224.
- 2 PC coils cannot be used in downflow or horizontal applications. FC coils cannot be used in horizontal applications.
- 3 A TXV kit must be used with these coils to obtain system performance.

Note: If a TXV is factory installed on the coil, it must be replaced with the listed TXV.

PROCEDURES:

1. Unit factory charge listed on the unit nameplate includes refrigerant for the condenser, the smallest evaporator and 15 feet of interconnecting line tubing.
2. Verify the TXV and additional charge required for specific evaporator coil in the system using the above table.
3. Additional charge for the amount of interconnecting line tubing greater than 15 feet at the rate specified on the previous page.
4. Permanently mark the unit nameplate with the total system charge. Total System Charge = Base Charge (as shipped) + adder for evaporator + adder for line set.

COOLING CAPACITY - With Air Handler Coils

UNIT MODEL	AIR HANDLER		COIL MODEL ¹	COOLING					
	MODEL	W		STAGE	RATED CFM	NET MBH		SEER	EER
CZE02411	AV24	17	-	1	650	18.5	14.9	15.00	12.70
				2	825	24.0	19.0		12.00
	AV36	21	-	1	625	18.5	14.9	15.00	13.20
				2	800	24.0	19.0		12.50
	MV12B	17	FC/MC36B	1	650	18.5	14.9	15.00	13.20
				2	825	24.0	19.0		12.50
CZE03611	AV36	21	-	1	830	25.0	17.5	15.00	12.70
				2	1200	35.0	25.4		12.15
	AV/SV48	24	-	1	810	23.8	17.5	15.25	13.20
				2	1200	36.0	26.3		12.50
	MV12B	17	FC/MC42B	1	775	23.8	17.5	15.25	12.40
				2	1200	35.0	26.3		12.00
	MV16C	21	FC/MC48C	1	775	25.4	18.7	15.50	13.20
				2	1185	36.0	27.2		12.50
	MV12D	24	FC/MC48D	1	775	25.4	18.8	15.75	13.25
				2	1185	36.0	27.2		12.50
	MV20D	24	FC/MC48D	1	775	25.4	18.8	15.75	13.25
				2	1185	36.0	27.2		12.50
CZE04811	AV/SV48	24	-	1	1130	33.4	25.1	15.00	13.20
				2	1600	47.0	36.6		12.50
	F*FV060	24	-	1	1000	33.4	25.1	15.75	13.20
				2	1600	47.0	36.6		12.50
	MV20D	24	FC/MC60D	1	1000	33.4	25.1	15.50	13.15
				2	1600	47.0	36.6		12.50
MV20D	24	MC61D	1	1000	33.6	25.3	16.00	13.30	
			2	1560	47.0	37.1		12.50	
CZE06011	AV/SV60	24	-	1	1145	39.0	29.5	13.75	11.60
				2	1845	54.0	42.4		11.00
	F*FV060	24	-	1	1200	39.0	29.5	13.75	11.60
				2	1845	55.0	42.4		11.00
	MV20D	24	FC/MC60D	1	1200	39.0	29.5	13.50	11.70
				2	1845	54.5	42.5		11.00
	MV20D	24	MC61D	1	1180	39.5	29.7	14.00	11.90
				2	1850	55.0	42.7		11.50

Rated in accordance with DOE test procedures (Federal Register 12-27-79 and 3-18-88) and ARI Standards 210.

Cooling MBH based on 80°F entering air temperature, 50% RH, and rated air flow.

EER (Energy Efficiency Ratio) is the total cooling output in BTU's at 95°F outdoor ambient divided by the total electric power in watt-hours at those conditions.

SEER (Seasonal Energy Efficiency Ratio) is the total cooling output in BTU's during a normal annual usage period for cooling divided by the total electric power input in watt-hours during the same period.

1 MC coils available with a factory installed horizontal drain pan. See price pages for specific model number.

COOLING CAPACITY - With Variable Speed Furnaces

UNIT MODEL	VARIABLE SPEED FURNACE MODEL	COIL MODEL ¹	W	COOLING					
				STAGE	RATED CFM	NET MBH		SEER	EER
						TOTAL	SENSIBLE		
CZE02411	PV8*A12	FC/MC/PC30A	14	1	580	18.2	14.2	15.00	13.15
				2	875	23.8	19.7		12.50
	PV9*A12	FC/MC/PC30A	14	1	625	18.4	14.8	14.75	13.05
				2	800	23.6	18.9		11.50
	P(C,V)9*B12	FC/MC/PC30B	17	1	625	18.4	14.8	14.75	13.05
				2	800	23.6	18.9		12.00
	PV8*A12	FC/MC/PC36A	14	1	560	18.2	14.6	15.00	13.15
				2	800	23.8	19.0		12.50
	PV9*A12	FC/MC/PC36A	14	1	560	18.2	14.6	15.00	13.15
				2	800	23.8	19.0		12.50
	P(C,V)9*B12	FC/MC/PC36B	17	1	560	18.2	14.6	15.00	13.15
				2	800	23.8	19.0		12.50
	P(C,V)9*B12	HD36	-	1	560	18.2	14.6	15.00	13.15
				2	800	23.8	19.0		12.50
CZE03611	PV8*B16	FC/MC/PC35B	17	1	795	24.0	18.0	15.00	12.55
				2	1200	35.4	27.2		12.00
	P(C,V)9*B12	FC/MC/PC35B	17	1	770	23.8	17.6	15.00	12.30
				2	1200	35.2	23.9		12.00
	PV8*C16	FC/MC/PC35C	21	1	795	24.0	18.0	15.50	12.55
				2	1200	35.4	27.2		12.00
	PV8*C20	FC/MC/PC35C	21	1	795	24.0	18.0	15.50	12.55
				2	1200	35.4	27.2		12.00
	P(C,V)9*C16	FC/MC/PC35C	21	1	770	23.8	17.6	15.00	12.30
				2	1200	35.2	23.9		12.00
	P(C,V)9*C20	FC/MC/PC35C	21	1	770	23.8	17.6	15.50	12.30
				2	1200	35.4	23.9		12.00
	PV8*B16	FC/MC/PC42B	17	1	795	24.0	18.0	15.00	12.55
				2	1200	35.4	27.2		12.00
	P(C,V)9*B12	FC/MC/PC42B	17	1	770	23.8	17.6	15.00	12.30
				2	1200	35.2	23.9		12.00
	PV8*C16	FC/MC/PC42C	21	1	795	24.0	18.0	15.50	12.55
				2	1200	35.4	27.2		12.00
	PV8*C20	FC/MC/PC42C	21	1	795	24.0	18.0	15.50	12.55
				2	1200	35.4	27.2		12.00
	P(C,V)9*C16	FC/MC/PC42C	21	1	770	23.8	17.6	15.00	12.30
				2	1200	35.2	23.9		12.00
	P(C,V)9*C20	FC/MC/PC42C	21	1	770	23.8	17.6	15.50	12.30
				2	1200	35.4	23.9		12.00
	PV8*C16	FC/MC/PC48C	21	1	780	25.4	19.0	15.50	13.30
				2	1200	35.4	27.6		12.50
	PV8*C20	FC/MC/PC48C	21	1	780	25.4	19.0	15.75	13.30
				2	1170	36.0	27.6		12.50
	P(C,V)9*C16	FC/MC/PC48C	21	1	780	25.4	18.8	15.50	13.10
				2	1200	36.0	25.5		12.50
	P(C,V)9*C20	FC/MC/PC48C	21	1	800	25.6	18.9	15.50	13.25
				2	1200	36.0	25.6		12.50
P(C,V)9*D20	FC/MC/PC48D	24	1	770	25.4	18.8	15.50	13.20	
			2	1200	36.0	25.5		12.50	
PV8*C20	HC42	21	1	795	24.0	18.0	15.00	12.55	
			2	1200	35.2	27.2		12.00	
P(C,V)9*C20	HC42	21	1	795	24.0	18.0	15.00	12.55	
			2	1200	35.2	27.2		12.00	
PV8*C20	HD48	-	1	795	24.0	18.0	15.00	12.55	
			2	1200	35.2	27.2		12.00	
P(C,V)9*C20	HD48	-	1	795	24.0	18.0	15.00	12.55	
			2	1200	35.2	27.2		12.00	

For notes see Page 6.

COOLING CAPACITY - With Variable Speed Furnaces (Continued)

UNIT MODEL	VARIABLE SPEED FURNACE MODEL	COIL MODEL ¹	W	COOLING					
				STAGE	RATED CFM	NET MBH		SEER	EER
						TOTAL	SENSIBLE		
CZE04811	PV8*C20	FC/PC60C	21	1	1030	33.6	25.8	15.50	13.10
				2	1610	47.0	37.6		12.00
	P(C,V)9*C20	FC/PC60C	21	1	1010	33.4	25.1	15.00	12.80
				2	1610	47.0	33.5		12.00
	PV8*C20	FC/MC/PC60D	24	1	1030	33.6	25.8	15.50	13.10
				2	1610	47.0	37.6		12.00
	P(C,V)9*D20	FC/MC/PC60D	24	1	1020	33.4	25.2	15.25	12.90
				2	1600	44.0	33.6		12.00
	PV8*C20	HC60	24	1	1030	33.6	25.8	15.50	13.10
				2	1610	47.0	37.6		12.00
	P(C,V)9*D20	HC60	24	1	1020	33.4	25.2	15.25	12.90
				2	1600	44.0	33.6		12.00
	PV8*C20	HD60	-	1	1030	33.6	25.8	15.50	13.10
				2	1610	47.0	37.6		12.00
	P(C,V)9*D20	HD60	-	1	1020	33.4	25.2	15.25	12.90
				2	1600	44.0	33.6		12.00
PV8*C20	MC61D	24	1	1030	33.8	26.1	15.50	13.20	
			2	1500	47.0	36.7		12.50	
P(C,V)9*D20	MC61D	24	1	1020	33.8	25.4	15.50	13.05	
			2	1600	44.5	33.8		12.50	
PV8*C20	FC/MC62D	24	1	1030	33.6	25.8	15.50	13.10	
			2	1610	47.0	37.6		12.50	
P(C,V)9*D20	FC/MC62D	24	1	1020	33.4	25.2	15.50	12.90	
			2	1600	44.0	33.6		12.50	
CZE06011	PV8*C20	FC/PC60C	21	1	1120	38.5	28.9	13.50	11.50
				2	1730	54.5	42.1		11.00
	P(C,V)9*C20	FC/PC60C	21	1	1040	38.5	28.9	13.25	11.35
				2	1620	54.0	38.6		11.00
	PV8*C20	FC/MC/PC60D	24	1	1120	38.5	28.9	13.50	11.50
				2	1730	54.5	42.1		11.00
	P(C,V)9*D20	FC/MC/PC60D	24	1	1030	38.5	28.9	13.25	11.40
				2	1620	54.0	38.6		11.00
	P(C,V)9*D20	HC60	24	1	1030	38.5	28.9	13.25	11.40
				2	1620	54.0	38.6		11.00
	PV8*C20	HD60	-	1	1120	38.5	28.9	13.25	11.50
				2	1620	54.0	42.1		11.00
	P(C,V)9*D20	HD60	-	1	1030	38.5	28.9	13.50	11.40
				2	1620	54.0	38.6		11.00
	P(C,V)9*C20	MC61D	24	1	1030	38.5	29.1	13.25	11.50
				2	1640	54.5	38.8		11.00
P(C,V)9*D20	MC61D	24	1	1030	38.5	29.1	13.50	11.50	
			2	1620	54.5	38.8		11.00	

1 MC coils available with a factory installed horizontal drain pan.

ACCESSORIES*

Hard Start Kit (024-31994-000, 024-31995-000) - Provides increased starting torque for areas with low voltage.

TXV Kits - 1TVM9 series thermal expansion valves precisely meter refrigerant for optimum performance

Dehumidistat (2HU16700124) - Provides increased dehumidification when matched with variable speed furnace or air handler.

Room Thermostats - A wide selection of compatible thermostats are available to provide optimum performance and features for any installation.

1 Heat Stage only, manual, mechanical thermostat. Add sub-base for 3H/2C.

3H/2C, manual changeover electronic non-programmable thermostat.

3H/2C, auto/manual changeover, electronic programmable, deluxe 7-day, thermostat.

3H/2C, auto/manual changeover, electronic programmable.

* For the most current accessory information, refer to the price book or consult factory.

SOUND POWER RATINGS*

UNIT MODEL	(dBA)
024	71
036	73
048	72
060	74

* Rated in accordance with ARI 270-95 Standards.

COLOR GRILLES

CHOICE OF SEVERAL COLOR COIL GRILLES TO COMPLIMENT ANY HOME.		
Color Grill	Color Description	
1CP0130	Terra Cotta	024
1CP0136	Terra Cotta	036, 048, 060
1CP0230	Jet Black	024
1CP0236	Jet Black	036, 048, 060
1CP0330	Stone	024
1CP0336	Stone	036, 048, 060
1CP0430	Bermuda	024
1CP0436	Bermuda	036, 048, 060
1CP0530	Gunmetal	024
1CP0536	Gunmetal	036, 048, 060
1CP0630	Chocolate	024
1CP0636	Chocolate	036, 048, 060

COOLING PERFORMANCE DATA - LOW CFM 1-STAGE OPERATION																
OUTDOOR UNIT MODEL NO.		CZE02411														
INDOOR COIL MODEL NO.		FC/MC36B + MV12B														
CONDENSER ENTERING AIR TEMPERATURE	ID CFM	550					600					650				
	ID DB (°F)	80	80	75	80	80	80	80	75	80	80	80	80	75	80	80
	ID WB (°F)	57	62	62	67	72	57	62	62	67	72	57	62	62	67	72
65	T.C.	16.5	17.0	16.4	15.3	19.2	17.1	17.2	16.5	17.2	19.6	17.6	17.5	16.6	19.0	20.0
	S.C.	17.0	16.3	13.7	11.9	10.9	17.5	17.1	14.0	13.6	11.2	17.9	18.0	14.2	15.2	11.5
	K.W.	0.8	0.7	0.7	0.5	0.7	0.7	0.7	0.8	0.6	0.7	0.6	0.7	0.8	0.7	0.7
75	T.C.	15.8	16.1	15.4	17.2	18.3	16.3	16.4	15.7	17.6	18.6	16.9	16.7	16.0	18.0	18.9
	S.C.	16.2	15.7	13.1	13.4	10.6	16.7	16.5	13.5	14.0	10.8	17.2	17.3	13.9	14.6	11.1
	K.W.	0.9	0.9	0.9	0.9	0.8	0.8	0.8	0.9	0.9	0.9	0.8	0.8	0.9	0.9	0.9
85	T.C.	15.1	15.2	14.5	19.0	17.4	15.6	15.6	15.0	18.1	17.6	16.2	15.9	15.4	17.1	17.7
	S.C.	15.4	15.2	12.5	14.9	10.3	15.9	15.9	13.0	14.5	10.5	16.4	16.7	13.5	14.0	10.6
	K.W.	1.0	1.0	1.0	1.3	1.0	1.0	1.0	1.0	1.1	1.0	0.9	0.9	1.0	1.0	1.0
95	T.C.	14.4	14.3	13.5	20.9	16.5	14.9	14.7	14.2	18.5	16.6	15.5	15.1	14.8	16.1	16.6
	S.C.	14.6	14.6	11.9	16.4	10.0	15.2	15.3	12.5	14.9	10.1	15.7	16.0	13.2	13.3	10.2
	K.W.	1.2	1.2	1.2	1.6	1.1	1.1	1.1	1.2	1.4	1.2	1.1	1.1	1.2	1.2	1.2
105	T.C.	13.7	13.3	12.5	19.5	15.5	14.1	13.8	13.0	17.2	15.4	14.6	14.2	13.5	15.0	15.3
	S.C.	13.9	13.7	11.2	15.7	9.6	14.4	14.4	11.9	14.3	9.7	14.8	15.0	12.5	12.9	9.8
	K.W.	1.4	1.4	1.4	1.9	1.3	1.3	1.3	1.4	1.6	1.3	1.3	1.3	1.4	1.4	1.4
115	T.C.	13.0	12.4	11.5	18.1	14.4	13.4	12.9	11.9	16.0	14.3	13.8	13.4	12.3	13.9	14.1
	S.C.	13.1	12.9	10.6	15.0	9.3	13.6	13.5	11.2	13.7	9.4	14.0	14.1	11.9	12.5	9.5
	K.W.	1.6	1.6	1.6	2.1	1.5	1.5	1.5	1.5	1.8	1.5	1.5	1.5	1.5	1.6	1.6
125	T.C.	12.3	11.4	10.5	16.7	13.3	12.6	12.0	10.7	14.8	13.1	13.0	12.6	11.0	12.8	12.9
	S.C.	12.4	12.1	9.9	14.3	8.9	12.8	12.6	10.6	13.2	9.0	13.2	13.1	11.3	12.1	9.1
	K.W.	1.7	1.8	1.7	2.4	1.7	1.7	1.7	1.7	2.1	1.7	1.7	1.7	1.7	1.7	1.7

NOTE: ALL CAPACITIES ARE NET (KBTUH) WITH INDOOR FAN HEAT ALREADY DEDUCTED AT 1250 BTUH/1000 CFM.

Multipliers for determining the performance with other indoor sections.

NOTE: For dry bulb temperatures different than those listed (between 73-87 F), sensible capacity increases by 1060 BTUH per 1000 CFM per degree above the listed temperature and decreases by 1060 BTUH per 1000 CFM per degree below the listed temperature.

NOTE: KW RATING IS FOR OUTDOOR AND INDOOR UNITS.

LOW CFM

Air Handler	Coil	T.C.	S.C.	KW
AV24	-	1.00	1.00	1.02
AV36	-	1.00	1.00	1.00

Variable Speed Furnace	Coil	T.C.	S.C.	KW
P(C,V)9*B12	FC/MC/PC24B	0.99	0.99	1.01
PV8*A12	FC/MC/PC30A	0.99	0.99	1.01
PV9*A12	FC/MC/PC30A	0.99	0.99	1.01
P(C,V)9*B12	FC/MC/PC30B	0.99	0.99	1.01
PV8*A12	FC/MC/PC36A	0.99	0.98	0.99
P(C,V)9*B12	FC/MC/PC36B	0.99	0.98	0.99
PV9*A12	HD36	0.99	0.99	1.01

COOLING PERFORMANCE DATA - HIGH CFM 2-STAGE OPERATION																
OUTDOOR UNIT MODEL NO.		CZE02411														
INDOOR COIL MODEL NO.		FC/MC36B + MV12B														
CONDENSER ENTERING AIR TEMPERATURE	ID CFM	700					800					900				
	ID DB (°F)	80	80	75	80	80	80	80	75	80	80	80	80	75	80	80
	ID WB (°F)	57	62	62	67	72	57	62	62	67	72	57	62	62	67	72
		57	62	62	67	72	57	62	62	67	72	57	62	62	67	72
65	T.C.	24.4	25.4	24.4	27.1	28.8	25.2	25.7	24.8	27.4	29.1	26.0	26.0	25.2	27.8	29.3
	S.C.	24.4	23.9	19.6	19.7	15.7	25.1	24.7	20.3	20.3	16.1	25.9	25.6	21.0	21.0	16.4
	K.W.	1.3	24.1	1.3	1.4	1.4	1.3	12.7	1.3	1.4	1.4	1.3	1.3	1.3	1.4	1.4
75	T.C.	23.7	24.2	23.3	26.0	27.5	24.4	24.6	23.7	26.3	27.7	25.1	25.1	24.1	26.6	27.9
	S.C.	23.6	23.1	19.0	19.2	15.2	24.3	24.0	19.7	19.9	15.6	25.0	24.8	20.4	20.5	15.9
	K.W.	1.5	16.7	1.5	1.5	1.6	1.5	9.1	1.5	1.5	1.6	1.5	1.5	1.5	1.5	1.6
85	T.C.	23.0	22.9	22.2	24.9	26.1	23.6	23.5	22.6	25.1	26.3	24.2	24.1	22.9	25.4	26.6
	S.C.	22.9	22.2	18.4	18.8	14.6	23.4	23.2	19.1	19.4	15.1	24.0	24.1	19.8	20.1	15.5
	K.W.	1.7	9.2	1.7	1.7	1.8	1.7	5.5	1.7	1.7	1.8	1.7	1.7	1.7	1.7	1.8
95	T.C.	22.3	21.7	21.2	23.8	24.8	22.8	22.4	21.5	24.0	25.0	23.3	23.2	21.8	24.2	25.2
	S.C.	22.1	21.4	17.9	18.4	14.1	22.6	22.4	18.5	19.0	14.6	23.0	23.4	19.2	19.6	15.0
	K.W.	1.9	1.8	1.9	1.9	2.0	1.9	1.9	1.9	1.9	2.0	1.9	1.9	1.9	1.9	2.0
105	T.C.	21.1	20.4	19.7	22.1	23.0	21.6	21.1	20.1	22.4	23.2	22.1	21.7	20.3	22.7	23.4
	S.C.	21.0	20.4	17.0	17.5	13.5	21.4	21.2	17.6	18.1	13.9	21.8	22.0	18.3	18.7	14.3
	K.W.	2.2	2.1	2.2	2.2	2.3	2.2	2.2	2.2	2.2	2.3	2.2	2.2	2.2	2.2	2.3
115	T.C.	20.0	19.2	18.4	20.6	21.2	20.5	19.8	18.7	20.9	21.5	20.9	20.2	19.0	21.1	21.7
	S.C.	20.0	19.5	16.1	16.7	13.0	20.3	20.1	16.8	17.3	13.3	20.7	20.6	17.4	17.8	13.7
	K.W.	2.5	2.4	2.5	2.5	2.6	2.5	2.5	2.5	2.5	2.5	2.5	2.5	2.5	2.5	2.5
125	T.C.	18.9	18.0	17.0	19.0	19.5	19.3	18.4	17.3	19.3	19.8	19.7	18.8	17.6	19.6	20.0
	S.C.	18.9	18.6	15.2	15.9	12.4	19.2	18.9	15.9	16.5	12.7	19.5	19.3	16.6	17.0	13.0
	K.W.	2.8	2.7	2.7	2.8	2.8	2.8	2.7	2.7	2.8	2.8	2.8	2.8	2.8	2.8	2.8

NOTE: ALL CAPACITIES ARE NET (KBTUH) WITH INDOOR FAN HEAT ALREADY DEDUCTED AT 1250 BTUH/1000 CFM.

Multipliers for determining the performance with other indoor sections.

NOTE: For dry bulb temperatures different than those listed (between 73-87 F), sensible capacity increases by 1060 BTUH per 1000 CFM per degree above the listed temperature and decreases by 1060 BTUH per 1000 CFM per degree below the listed temperature.

NOTE: KW RATING IS FOR OUTDOOR AND INDOOR UNITS.

HIGH CFM

Air Handler	Coil	T.C.	S.C.	KW
AV24	—	1.00	1.00	1.04
AV36	—	1.00	1.00	1.00

Variable Speed Furnace	Coil	T.C.	S.C.	KW
P(C,V)9*B12	FC/MC/PC24B	0.98	0.99	1.02
PV8*A12	FC/MC/PC30A	0.98	0.99	1.02
PV9*A12	FC/MC/PC30A	0.98	0.99	1.02
P(C,V)9*B12	FC/MC/PC30B	0.98	0.99	1.02
PV8*A12	FC/MC/PC36A	0.99	1.00	1.00
P(C,V)9*B12	FC/MC/PC36B	0.99	1.00	1.00
PV9*A12	HD36	0.98	0.99	1.02

COOLING PERFORMANCE DATA - LOW CFM 1-STAGE OPERATION																
OUTDOOR UNIT MODEL NO.		CZE03611														
INDOOR COIL MODEL NO.		FC/MC48C + MV16C														
CONDENSER ENTERING AIR TEMPERATURE	ID CFM	750					800					850				
	ID DB (°F)	80	80	75	80	80	80	80	75	80	80	80	80	75	80	80
	ID WB (°F)	57	62	62	67	72	57	62	62	67	72	57	62	62	67	72
65	T.C.	26.9	27.8	26.7	30.6	31.8	27.4	27.9	27.1	30.8	32.3	28.0	27.9	27.4	31.1	32.7
	S.C.	25.7	25.5	20.0	20.1	16.1	26.3	24.9	20.7	20.9	16.4	26.8	24.3	21.3	21.7	16.8
	K.W.	1.2	1.3	1.2	1.2	1.2	1.2	1.2	1.3	1.2	1.2	1.2	1.2	1.3	1.2	1.2
75	T.C.	25.1	26.1	25.4	28.8	30.6	25.6	26.2	25.7	29.0	31.0	26.2	26.4	26.0	29.2	31.3
	S.C.	24.3	23.9	19.3	19.4	15.5	24.9	23.8	20.0	20.2	15.9	25.5	23.7	20.6	20.9	16.3
	K.W.	1.5	1.5	1.5	1.4	1.4	1.5	1.5	1.5	1.4	1.4	1.5	1.5	1.5	1.4	1.4
85	T.C.	23.2	24.4	24.1	27.0	29.3	23.8	24.6	24.3	27.2	29.7	24.4	24.9	24.6	27.4	30.0
	S.C.	23.0	22.4	18.6	18.7	15.0	23.6	22.7	19.3	19.4	15.4	24.3	23.1	19.9	20.1	15.9
	K.W.	1.7	1.7	1.7	1.7	1.7	1.7	1.7	1.7	1.7	1.7	1.7	1.7	1.7	1.7	1.7
95	T.C.	21.3	22.7	22.8	25.2	28.1	22.0	23.0	23.0	25.4	28.4	22.7	23.4	23.2	25.5	28.6
	S.C.	21.7	20.9	17.9	18.1	14.4	22.3	21.7	18.6	18.7	14.9	23.0	22.4	19.2	19.3	15.5
	K.W.	2.0	2.0	2.0	1.9	1.9	2.0	2.0	1.9	1.9	1.9	1.9	1.9	1.9	1.9	1.9
105	T.C.	20.3	21.3	21.2	23.6	26.2	20.9	21.6	21.5	23.7	26.4	21.5	21.8	21.7	23.9	26.6
	S.C.	20.6	19.7	17.1	17.4	13.8	21.2	20.4	17.7	18.0	14.2	21.8	21.0	18.3	18.6	14.7
	K.W.	2.3	2.3	2.3	2.3	2.2	2.3	2.3	2.3	2.3	2.2	2.3	2.3	2.3	2.3	2.2
115	T.C.	19.4	20.0	19.7	22.0	24.3	19.8	20.2	20.0	22.1	24.5	20.3	20.3	20.2	22.2	24.6
	S.C.	19.6	18.5	16.3	16.7	13.2	20.1	19.1	16.9	17.3	13.6	20.6	19.7	17.5	17.9	13.9
	K.W.	2.6	2.6	2.6	2.6	2.6	2.6	2.6	2.6	2.6	2.6	2.6	2.6	2.6	2.6	2.6
125	T.C.	18.4	18.7	18.3	20.5	22.4	18.7	18.7	18.5	20.5	22.6	19.1	18.8	18.7	20.6	22.7
	S.C.	18.6	17.4	15.5	16.1	12.6	19.0	17.8	16.1	16.7	12.9	19.4	18.3	16.6	17.2	13.2
	K.W.	3.0	2.9	3.0	2.9	2.9	2.9	2.9	2.9	2.9	2.9	2.9	2.9	2.9	2.9	2.9

NOTE: ALL CAPACITIES ARE NET (KBTUH) WITH INDOOR FAN HEAT ALREADY DEDUCTED AT 1250 BTUH/1000 CFM.

Multipliers for determining the performance with other indoor sections.

NOTE: For dry bulb temperatures different than those listed (between 73-87 F), sensible capacity increases by 1060 BTUH per 1000 CFM per degree above the listed temperature and decreases by 1060 BTUH per 1000 CFM per degree below the listed temperature.

NOTE: KW RATING IS FOR OUTDOOR AND INDOOR UNITS.

LOW CFM

Air Handler	Coil	T.C.	S.C.	KW
AV36	-	0.97	0.94	0.96
AV/SV48	-	1.00	1.00	1.00
MV12B	FC/MC35B	0.97	0.94	1.01
MV12B	FC/MC42B	0.97	0.94	1.01
MV20D	FC/MC48D	1.00	1.01	1.00

Variable Speed Furnace	Coil	T.C.	S.C.	KW
PV8*B16	FC/MC/PC35B	0.98	0.96	1.01
P(C,V)9*B12	FC/MC/PC35B	0.98	0.94	1.03
PV8*C16	FC/MC/PC35C	0.98	0.94	1.03
PV8*C20	FC/MC/PC35C	0.98	0.94	1.03
P(C,V)9*C16	FC/MC/PC35C	0.98	0.94	1.03
P(C,V)9*C20	FC/MC/PC35C	0.98	0.94	1.03
PV8*B16	FC/MC/PC42B	0.98	0.96	1.01
P(C,V)9*B12	FC/MC/PC42B	0.98	0.94	1.03
PV8*C16	FC/MC/PC42C	0.98	0.94	1.03
PV8*C20	FC/MC/PC42C	0.98	0.94	1.03
P(C,V)9*C16	FC/MC/PC42C	0.98	0.94	1.03
P(C,V)9*C20	FC/MC/PC42C	0.98	0.94	1.03
PV8*C16	FC/MC/PC48C	1.00	1.02	1.00
PV8*C20	FC/MC/PC48C	1.00	1.02	1.00
P(C,V)9*C16	FC/MC/PC48C	1.00	1.01	1.01
P(C,V)9*C20	FC/MC/PC48C	1.00	1.01	1.01
P(C,V)9*D20	FC/MC/PC48D	1.00	1.01	1.01
PV8*C20	HC42	0.98	0.94	1.03
P(C,V)9*C20	HC42	0.98	0.94	1.03
PV8*C20	HD48	0.98	0.94	1.03
P(C,V)9*C20	HD48	0.98	0.94	1.03

COOLING PERFORMANCE DATA - HIGH CFM 2-STAGE OPERATION																	
OUTDOOR UNIT MODEL NO.		CZE03611															
INDOOR COIL MODEL NO.		FC/MC48C + MV16C															
CONDENSER ENTERING AIR TEMPERATURE	ID CFM	1100					1200					1300					
	ID DB (°F)	80	80	75	80	80	80	80	75	80	80	80	80	75	80	80	
	ID WB (°F)	57	62	62	67	72	57	62	62	67	72	57	62	62	67	72	
65	T.C.	34.1	36.8	36.5	38.0	39.8	34.7	37.1	36.6	37.5	39.3	35.4	37.3	36.6	37.1	38.8	
	S.C.	35.3	32.2	26.2	26.1	20.1	36.6	32.8	28.0	25.9	20.3	37.0	33.5	29.8	25.7	20.5	
	K.W.	1.9	2.0	2.1	2.0	2.0	1.9	2.0	2.1	2.0	2.1	2.0	2.0	2.0	2.0	2.1	
75	T.C.	33.2	35.5	35.1	37.3	39.1	33.9	35.7	35.3	37.0	38.8	34.6	36.0	35.5	36.8	38.5	
	S.C.	34.5	32.0	26.3	26.1	20.3	35.6	32.7	27.9	26.3	20.5	36.8	33.4	29.4	26.5	20.7	
	K.W.	2.2	2.2	2.3	2.3	2.3	2.2	2.3	2.3	2.3	2.3	2.3	2.3	2.3	2.3	2.4	
85	T.C.	32.4	34.1	33.8	36.5	38.5	33.1	34.4	34.1	36.5	38.4	33.8	34.6	34.3	36.5	38.3	
	S.C.	33.7	31.7	26.5	26.2	20.5	34.6	32.6	27.8	26.8	20.7	35.5	33.4	29.0	27.3	20.8	
	K.W.	2.5	2.5	2.6	2.6	2.6	2.5	2.5	2.5	2.6	2.6	2.6	2.6	2.5	2.6	2.6	
95	T.C.	31.6	32.7	32.4	35.8	37.8	32.3	33.0	32.8	36.0	37.9	32.9	33.3	33.2	36.2	38.0	
	S.C.	32.9	31.5	26.6	26.3	20.6	33.6	32.4	27.6	27.2	20.8	34.3	33.3	28.6	28.1	21.0	
	K.W.	2.8	2.8	2.8	2.8	2.9	2.8	2.8	2.8	2.9	2.9	2.8	2.8	2.8	2.9	2.9	
105	T.C.	29.1	30.7	30.5	33.5	34.7	29.9	30.9	30.8	33.7	35.5	30.7	31.1	31.1	33.9	36.2	
	S.C.	30.3	30.3	25.2	25.1	21.4	31.1	30.6	26.1	26.0	20.9	32.0	30.8	27.0	26.9	20.5	
	K.W.	3.2	3.2	3.2	3.3	3.3	3.2	3.2	3.2	3.3	3.3	3.3	3.3	3.2	3.3	3.3	
115	T.C.	26.7	28.8	28.5	31.3	31.7	27.6	28.9	28.9	31.5	33.1	28.5	29.0	29.1	31.8	34.4	
	S.C.	27.7	29.1	23.8	23.9	22.1	28.8	28.8	24.6	24.8	21.0	29.8	28.4	25.4	25.7	19.9	
	K.W.	3.6	3.6	3.6	3.7	3.7	3.7	3.6	3.6	3.7	3.7	3.7	3.7	3.7	3.7	3.7	
125	T.C.	24.2	26.9	26.6	29.0	28.8	25.3	26.9	26.9	29.4	30.7	26.3	26.9	27.2	29.6	32.7	
	S.C.	25.1	27.9	22.4	22.7	22.9	26.4	27.0	23.1	23.6	21.1	27.6	26.0	23.8	24.5	19.3	
	K.W.	4.0	4.0	4.0	4.1	4.1	4.1	4.1	4.0	4.1	4.1	4.1	4.1	4.1	4.1	4.2	

NOTE: ALL CAPACITIES ARE NET (KBTUH) WITH INDOOR FAN HEAT ALREADY DEDUCTED AT 1250 BTUH/1000 CFM.

Multipliers for determining the performance with other indoor sections.

NOTE: For dry bulb temperatures different than those listed (between 73-87 F), sensible capacity increases by 1060 BTUH per 1000 CFM per degree above the listed temperature and decreases by 1060 BTUH per 1000 CFM per degree below the listed temperature.

NOTE: KW RATING IS FOR OUTDOOR AND INDOOR UNITS.

HIGH CFM

Air Handler	Coil	T.C.	S.C.	KW
AV36	-	0.97	0.99	1.01
AV/SV48	-	1.00	1.00	1.00
MV12B	FC/MC35B	0.97	0.97	1.01
MV12B	FC/MC42B	0.97	0.97	1.01
MV20D	FC/MC48D	1.00	1.01	1.00

Variable Speed Furnace	Coil	T.C.	S.C.	KW
PV8*B16	FC/MC/PC35B	0.98	1.00	1.01
P(C,V)9*B12	FC/MC/PC35B	0.98	0.88	1.03
PV8*C16	FC/MC/PC35C	1.00	1.01	1.00
PV8*C20	FC/MC/PC35C	1.00	1.01	1.00
P(C,V)9*C16	FC/MC/PC35C	1.00	0.94	1.01
P(C,V)9*C20	FC/MC/PC35C	1.00	0.94	1.01
PV8*B16	FC/MC/PC42B	0.98	1.00	1.01
P(C,V)9*B12	FC/MC/PC42B	0.98	0.88	1.03
PV8*C16	FC/MC/PC42C	1.00	1.01	1.00
PV8*C20	FC/MC/PC42C	1.00	1.01	1.00
P(C,V)9*C16	FC/MC/PC42C	1.00	0.94	1.01
P(C,V)9*C20	FC/MC/PC42C	1.00	0.94	1.01
PV8*C16	FC/MC/PC48C	1.00	1.01	1.00
PV8*C20	FC/MC/PC48C	1.00	1.01	1.00
P(C,V)9*C16	FC/MC/PC48C	1.00	0.94	1.01
P(C,V)9*C20	FC/MC/PC48C	1.00	0.94	1.01
P(C,V)9*D20	FC/MC/PC48D	1.00	0.94	1.01
PV8*C20	HC42	1.00	1.01	1.00
P(C,V)9*C20	HC42	1.00	0.94	1.01
PV8*C20	HD48	1.00	1.01	1.00
P(C,V)9*C20	HD48	1.00	0.94	1.01

COOLING PERFORMANCE DATA - LOW CFM 1-STAGE OPERATION																
OUTDOOR UNIT MODEL NO.		CZE04811														
INDOOR COIL MODEL NO.		FC/MC60D + MV20D														
CONDENSER ENTERING AIR TEMPERATURE	ID CFM	950					1000					1050				
	ID DB (°F)	80	80	75	80	80	80	80	75	80	80	80	80	75	80	80
	ID WB (°F)	57	62	62	67	72	57	62	62	67	72	57	62	62	67	72
65	T.C.	29.9	33.7	34.9	37.9	45.0	31.0	34.1	35.3	38.5	45.5	32.1	34.5	35.8	39.0	46.1
	S.C.	33.1	31.3	26.6	26.1	21.6	34.2	32.4	27.6	27.0	22.3	35.4	33.5	28.6	27.8	22.9
	K.W.	1.6	1.6	1.6	1.6	1.6	1.6	1.6	1.6	1.6	1.6	1.6	1.6	1.6	1.6	1.6
75	T.C.	28.3	31.6	32.6	36.3	42.7	29.3	32.1	33.1	36.8	43.2	30.4	32.5	33.5	37.3	43.7
	S.C.	31.3	30.0	25.4	25.5	20.9	32.4	31.1	26.4	26.4	21.5	33.5	32.1	27.4	27.2	22.1
	K.W.	2.0	1.9	1.9	1.9	1.9	1.9	1.9	1.9	1.9	1.9	1.9	1.9	1.9	1.9	1.9
85	T.C.	26.7	29.5	30.3	34.6	40.3	27.6	30.0	30.8	35.1	40.8	28.6	30.5	31.3	35.6	41.2
	S.C.	29.5	28.8	24.3	24.8	20.1	30.5	29.8	25.3	25.7	20.7	31.6	30.7	26.3	26.6	21.3
	K.W.	2.3	2.2	2.3	2.2	2.2	2.3	2.2	2.3	2.2	2.2	2.2	2.2	2.3	2.2	2.2
95	T.C.	25.1	27.5	28.0	32.9	38.0	26.0	28.0	28.5	33.4	38.4	26.9	28.5	29.0	33.9	38.8
	S.C.	27.7	27.6	23.2	24.2	19.3	28.7	28.5	24.2	25.1	19.9	29.7	29.3	25.1	26.0	20.5
	K.W.	2.6	2.6	2.6	2.5	2.5	2.6	2.5	2.6	2.5	2.5	2.6	2.5	2.6	2.5	2.5
105	T.C.	23.7	25.4	25.8	30.2	35.1	24.5	25.9	26.3	30.6	35.5	25.3	26.3	26.8	31.0	35.9
	S.C.	26.1	25.8	22.1	23.2	18.4	27.0	26.6	23.0	24.0	18.9	27.9	27.4	23.9	24.9	19.4
	K.W.	3.0	3.0	3.0	3.0	3.0	3.0	3.0	3.0	3.0	3.0	3.0	3.0	3.0	3.0	3.0
115	T.C.	22.4	23.4	23.7	27.7	32.2	23.0	23.8	24.1	28.0	32.6	23.7	24.2	24.6	28.3	33.0
	S.C.	24.6	23.9	21.0	22.2	17.5	25.4	24.7	21.9	23.0	18.0	26.2	25.5	22.8	23.8	18.4
	K.W.	3.4	3.4	3.4	3.4	3.4	3.4	3.4	3.4	3.4	3.4	3.4	3.4	3.4	3.4	3.4
125	T.C.	21.1	21.4	21.6	25.1	29.3	21.6	21.8	22.0	25.3	29.7	22.1	22.1	22.4	25.5	30.1
	S.C.	23.0	22.1	19.9	21.2	16.5	23.7	22.9	20.8	22.0	17.0	24.4	23.6	21.6	22.7	17.4
	K.W.	3.8	3.8	3.8	3.8	3.8	3.8	3.8	3.8	3.8	3.8	3.8	3.8	3.8	3.8	3.8

NOTE: ALL CAPACITIES ARE NET (KBTUH) WITH INDOOR FAN HEAT ALREADY DEDUCTED AT 1250 BTUH/1000 CFM.

Multipliers for determining the performance with other indoor sections.

NOTE: For dry bulb temperatures different than those listed (between 73-87 F), sensible capacity increases by 1060 BTUH per 1000 CFM per degree above the listed temperature and decreases by 1060 BTUH per 1000 CFM per degree below the listed temperature.

NOTE: KW RATING IS FOR OUTDOOR AND INDOOR UNITS.

LOW CFM

Air Handler	Coil	T.C.	S.C.	KW
AV/SV48	–	1.00	1.00	1.00
AV/SV60	–	1.00	1.00	1.00
F*FV060	–	1.00	1.00	1.00
MV20D	MC61D	1.00	1.01	0.99

Variable Speed Furnace	Coil	T.C.	S.C.	KW
PV8*C20	FC/PC60C	1.00	1.03	1.02
P(C,V)9*C20	FC/PC60C	0.94	1.00	0.93
PV8*C20	FC/MC/PC60D	1.00	1.03	1.02
P(C,V)9*D20	FC/MC/PC60D	0.94	1.00	0.92
PV8*C20	HC60	1.00	1.03	1.02
P(C,V)9*D20	HC60	0.94	1.00	0.92
PV8*C20	HD60	1.00	1.03	1.02
P(C,V)9*D20	HD60	0.94	1.00	0.92
PV8*C20	MC61D	1.00	1.04	1.00
P(C,V)9*D20	MC61D	0.95	1.01	0.93

COOLING PERFORMANCE DATA - HIGH CFM 2-STAGE OPERATION																
OUTDOOR UNIT MODEL NO.		CZE04811														
INDOOR COIL MODEL NO.		FC/MC60D + MV20D														
CONDENSER ENTERING AIR TEMPERATURE	ID CFM	1500					1600					1700				
	ID DB (°F)	80	80	75	80	80	80	80	75	80	80	80	80	75	80	80
	ID WB (°F)	57	62	62	67	72	57	62	62	67	72	57	62	62	67	72
65	T.C.	49.7	52.5	48.5	54.2	62.6	50.6	52.9	49.1	54.8	63.1	51.6	53.3	49.6	55.3	63.6
	S.C.	52.8	50.4	38.3	38.5	30.4	53.8	51.3	39.7	39.7	31.3	54.8	52.2	41.1	41.0	32.3
	K.W.	2.6	2.6	2.6	2.7	2.8	2.6	2.7	2.7	2.7	2.9	2.7	2.7	2.7	2.8	2.9
75	T.C.	47.4	49.9	46.0	51.7	59.5	48.3	50.4	46.5	52.2	60.0	49.2	50.8	47.1	52.7	60.4
	S.C.	50.4	48.4	37.1	37.4	29.6	51.3	49.4	38.5	38.7	30.5	52.2	50.4	39.8	39.9	31.3
	K.W.	2.9	3.0	2.9	3.0	3.2	3.0	3.0	3.0	3.1	3.2	3.0	3.0	3.0	3.1	3.2
85	T.C.	45.2	47.4	43.5	49.2	56.4	46.0	47.9	44.0	49.6	56.8	46.9	48.4	44.5	50.0	57.2
	S.C.	47.9	46.4	35.9	36.4	28.9	48.8	47.5	37.2	37.6	29.6	49.7	48.6	38.5	38.9	30.2
	K.W.	3.3	3.3	3.3	3.4	3.5	3.3	3.3	3.3	3.4	3.5	3.4	3.4	3.4	3.5	3.6
95	T.C.	42.9	44.9	40.9	46.7	53.3	43.7	45.5	41.5	47.0	53.7	44.5	46.0	41.9	47.3	54.1
	S.C.	45.5	44.4	34.6	35.3	28.1	46.3	45.6	35.9	36.6	28.7	47.1	46.7	37.2	37.9	29.2
	K.W.	3.6	3.6	3.6	3.7	3.8	3.6	3.7	3.6	3.8	3.9	3.7	3.7	3.7	3.8	3.9
105	T.C.	40.4	41.9	39.0	43.3	49.5	41.1	42.4	39.5	43.6	49.8	41.7	42.8	39.9	43.9	50.2
	S.C.	42.8	42.1	33.9	34.0	26.7	43.4	43.0	35.0	35.3	27.3	44.1	43.9	36.1	36.5	27.9
	K.W.	4.2	4.1	4.1	4.2	4.3	4.2	4.2	4.2	4.3	4.4	4.3	4.2	4.2	4.3	4.4
115	T.C.	37.9	39.0	37.2	40.1	45.7	38.4	39.4	37.6	40.4	46.1	38.9	39.8	38.0	40.6	46.3
	S.C.	40.1	39.9	33.2	32.7	25.3	40.6	40.5	34.2	33.9	26.0	41.1	41.1	35.1	35.1	26.7
	K.W.	4.7	4.7	4.7	4.7	4.8	4.8	4.7	4.7	4.8	4.9	4.8	4.8	4.7	4.8	4.9
125	T.C.	35.4	36.1	35.4	36.9	42.0	35.8	36.4	35.7	37.1	42.3	36.2	36.7	36.0	37.3	42.5
	S.C.	37.4	37.7	32.5	31.4	23.9	37.8	38.0	33.3	32.6	24.6	38.1	38.3	34.0	33.8	25.4
	K.W.	5.3	5.2	5.2	5.2	5.3	5.4	5.2	5.2	5.3	5.4	5.4	5.3	5.3	5.3	5.4

NOTE: ALL CAPACITIES ARE NET (KBTUH) WITH INDOOR FAN HEAT ALREADY DEDUCTED AT 1250 BTUH/1000 CFM.

Multipliers for determining the performance with other indoor sections

NOTE: For dry bulb temperatures different than those listed (between 73-87 F), sensible capacity increases by 1060 BTUH per 1000 CFM per degree above the listed temperature and decreases by 1060 BTUH per 1000 CFM per degree below the listed temperature.

NOTE: KW RATING IS FOR OUTDOOR AND INDOOR UNITS.

HIGH CFM

Air Handler	Coil	T.C.	S.C.	KW
AV/SV48	-	1.00	1.00	1.00
AV/SV60	-	1.00	1.00	1.00
F*FV060	-	1.00	1.00	1.00
MV20D	MC61D	1.00	1.01	0.99

Variable Speed Furnace	Coil	T.C.	S.C.	KW
PV8*C20	FC/PC60C	1.00	1.03	1.02
P(C,V)9*C20	FC/PC60C	0.94	0.92	0.93
PV8*C20	FC/MC/PC60D	1.00	1.03	1.02
P(C,V)9*D20	FC/MC/PC60D	0.94	0.92	0.92
PV8*C20	HC60	1.00	1.03	1.02
P(C,V)9*D20	HC60	0.94	0.92	0.92
PV8*C20	HD60	1.00	1.03	1.02
P(C,V)9*D20	HD60	0.94	0.92	0.92
PV8*C20	MC61D	1.00	1.00	1.00
P(C,V)9*D20	MC61D	0.95	0.92	0.93

COOLING PERFORMANCE DATA - LOW CFM 1-STAGE OPERATION																
OUTDOOR UNIT MODEL NO.		CZE06011														
INDOOR COIL MODEL NO.		MC61D + MV20D														
CONDENSER ENTERING AIR TEMPERATURE	ID CFM	1100					1150					1200				
	ID DB (°F)	80	80	75	80	80	80	80	75	80	80	80	80	75	80	80
	ID WB (°F)	57	62	62	67	72	57	62	62	67	72	57	62	62	67	72
65	T.C.	38.7	40.9	41.4	45.9	50.5	39.4	41.5	41.8	46.3	51.1	40.1	42.2	42.2	46.7	51.7
	S.C.	42.1	38.7	32.0	32.2	25.9	42.8	39.7	32.8	32.8	26.0	43.6	40.8	33.5	33.4	26.1
	K.W.	2.2	2.2	2.1	2.2	2.1	2.2	2.2	2.2	2.2	2.1	2.2	2.2	2.2	2.2	2.2
75	T.C.	37.0	39.1	39.4	43.7	48.1	37.6	39.6	39.8	44.0	48.7	38.2	40.2	40.1	44.4	49.3
	S.C.	40.2	37.2	31.1	31.2	25.0	40.8	38.1	31.8	31.8	25.1	41.5	39.1	32.5	32.3	25.3
	K.W.	2.6	2.6	2.5	2.5	2.5	2.6	2.6	2.6	2.5	2.5	2.6	2.6	2.6	2.6	2.5
85	T.C.	35.2	37.3	37.5	41.5	45.8	35.7	37.7	37.8	41.8	46.3	36.3	38.1	38.1	42.1	46.9
	S.C.	38.3	35.6	30.2	30.2	24.0	38.9	36.5	30.9	30.7	24.3	39.4	37.4	31.5	31.3	24.5
	K.W.	2.9	2.9	2.9	2.9	2.9	3.0	2.9	2.9	2.9	2.9	3.0	2.9	3.0	2.9	2.9
95	T.C.	33.5	35.5	35.5	39.2	43.4	33.9	35.8	35.7	39.5	44.0	34.3	36.1	36.0	39.8	44.5
	S.C.	36.5	34.1	29.4	29.1	23.0	36.9	35.0	30.0	29.7	23.4	37.3	35.8	30.5	30.3	23.7
	K.W.	3.3	3.3	3.3	3.3	3.3	3.3	3.3	3.3	3.3	3.3	3.3	3.3	3.3	3.3	3.3
105	T.C.	31.6	32.9	33.0	36.5	40.6	32.1	33.3	33.2	36.8	40.9	32.5	33.6	33.5	37.1	41.3
	S.C.	34.5	32.1	28.2	28.0	22.0	34.9	32.8	28.7	28.6	22.3	35.3	33.6	29.3	29.1	22.6
	K.W.	3.8	3.8	3.8	3.8	3.8	3.8	3.8	3.8	3.8	3.8	3.9	3.8	3.9	3.8	3.8
115	T.C.	29.8	30.5	30.6	33.9	37.8	30.3	30.8	30.8	34.2	38.0	30.8	31.1	31.0	34.4	38.2
	S.C.	32.5	30.2	27.1	26.9	20.9	33.0	30.8	27.6	27.5	21.2	33.4	31.4	28.0	28.1	21.6
	K.W.	4.4	4.3	4.3	4.3	4.3	4.4	4.3	4.3	4.3	4.3	4.4	4.3	4.3	4.3	4.3
125	T.C.	28.0	28.0	28.2	31.3	35.0	28.5	28.3	28.3	31.5	35.1	29.0	28.6	28.4	31.8	35.1
	S.C.	30.6	28.2	26.0	25.8	19.9	31.1	28.7	26.4	26.4	20.2	31.6	29.3	26.8	27.0	20.5
	K.W.	4.9	4.8	4.8	4.8	4.8	4.9	4.8	4.8	4.8	4.8	4.9	4.8	4.8	4.8	4.8

NOTE: ALL CAPACITIES ARE NET (KBTUH) WITH INDOOR FAN HEAT ALREADY DEDUCTED AT 1250 BTUH/1000 CFM.

Multipliers for determining the performance with other indoor sections.

NOTE: For dry bulb temperatures different than those listed (between 73-87 F), sensible capacity increases by 1060 BTUH per 1000 CFM per degree above the listed temperature and decreases by 1060 BTUH per 1000 CFM per degree below the listed temperature.

NOTE: KW RATING IS FOR OUTDOOR AND INDOOR UNITS.

LOW CFM

Air Handler	Coil	T.C.	S.C.	KW
AV/SV60	-	1.00	0.99	1.00
F*FV060	-	1.00	0.99	1.00
MV20D	FC/MC60D	0.99	0.99	0.99

Variable Speed Furnace	Coil	T.C.	S.C.	KW
PV8*C20	FC/PC60C	0.99	0.97	1.01
P(C,V)9*D20	FC/PC60C	0.98	0.97	0.99
PV8*C20	FC/MC/PC60D	0.99	0.97	1.01
P(C,V)9*D20	FC/MC/PC60D	0.98	0.97	0.99
PV8*C20	MC61D	0.99	0.98	0.99
P(C,V)9*D20	MC61D	0.99	0.98	0.99
P(C,V)9*D20	HC60	0.98	0.97	1.00
PV8*C20	HD60	0.99	0.97	1.01
P(C,V)9*D20	HD60	0.99	0.97	1.01

COOLING PERFORMANCE DATA - HIGH CFM 2-STAGE OPERATION																
OUTDOOR UNIT MODEL NO.		CZE06011														
INDOOR COIL MODEL NO.		MC61D + MV20D														
CONDENSER ENTERING AIR TEMPERATURE	ID CFM	1750					1850					1950				
	ID DB (°F)	80	80	75	80	80	80	80	75	80	80	80	80	75	80	80
	ID WB (°F)	57	62	62	67	72	57	62	62	67	72	57	62	62	67	72
65	T.C.	53.8	58.0	57.9	64.1	68.1	54.8	58.2	58.5	64.2	68.1	55.7	58.3	59.0	64.3	68.2
	S.C.	58.7	54.4	46.0	46.2	33.8	59.7	55.6	47.0	46.8	34.6	60.6	56.8	48.0	47.4	35.3
	K.W.	3.5	3.5	3.5	3.6	3.7	3.5	3.6	3.6	3.7	3.8	3.6	3.6	3.7	3.8	3.8
75	T.C.	51.8	55.2	55.5	61.1	65.7	52.6	55.5	55.8	61.3	65.9	53.4	55.9	56.1	61.5	66.1
	S.C.	56.4	52.9	44.9	44.7	33.4	57.3	54.2	45.8	45.4	34.1	58.1	55.5	46.7	46.2	34.7
	K.W.	3.9	4.0	4.0	4.1	4.2	4.0	4.0	4.0	4.1	4.2	4.1	4.1	4.1	4.2	4.3
85	T.C.	49.8	52.3	53.0	58.0	63.4	50.5	52.9	53.2	58.4	63.7	51.2	53.4	53.3	58.7	64.0
	S.C.	54.1	51.4	43.7	43.1	33.0	54.9	52.9	44.6	44.1	33.5	55.6	54.3	45.4	45.0	34.1
	K.W.	4.4	4.4	4.4	4.5	4.6	4.4	4.5	4.5	4.6	4.7	4.5	4.6	4.5	4.7	4.8
95	T.C.	47.7	49.5	50.5	55.0	61.1	48.4	50.2	50.5	55.5	61.5	48.9	51.0	50.5	56.0	62.0
	S.C.	51.9	49.9	42.5	41.6	32.6	52.5	51.5	43.3	42.7	33.0	53.1	53.0	44.1	43.7	33.4
	K.W.	4.8	4.9	4.9	5.0	5.1	4.9	4.9	4.9	5.0	5.2	5.0	5.0	5.0	5.1	5.3
105	T.C.	45.2	46.6	47.2	51.7	57.2	45.7	47.1	47.3	52.1	57.6	46.3	47.6	47.3	52.4	58.0
	S.C.	49.1	47.7	40.9	40.3	31.2	49.7	48.9	41.7	41.3	31.6	50.2	50.2	42.6	42.2	32.1
	K.W.	5.5	5.5	5.5	5.6	5.8	5.5	5.6	5.6	5.7	5.8	5.6	5.6	5.6	5.7	5.9
115	T.C.	42.7	43.8	44.0	48.5	53.5	43.2	44.1	44.2	48.7	53.9	43.7	44.4	44.3	49.0	54.2
	S.C.	46.4	45.5	39.3	39.1	29.8	46.9	46.5	40.2	40.0	30.3	47.4	47.5	41.1	40.8	30.8
	K.W.	6.1	6.2	6.1	6.2	6.4	6.2	6.2	6.2	6.3	6.4	6.3	6.3	6.2	6.4	6.5
125	T.C.	40.2	41.0	40.8	45.3	49.8	40.7	41.1	41.0	45.4	50.1	41.1	41.2	41.3	45.5	50.4
	S.C.	43.7	43.3	37.7	37.8	28.4	44.2	44.0	38.7	38.6	28.9	44.7	44.8	39.7	39.3	29.5
	K.W.	6.8	6.8	6.7	6.9	7.0	6.8	6.8	6.8	6.9	7.0	6.9	6.9	6.9	7.0	7.1

NOTE: ALL CAPACITIES ARE NET (KBTUH) WITH INDOOR FAN HEAT ALREADY DEDUCTED AT 1250 BTUH/1000 CFM.

Multipliers for determining the performance with other indoor sections.

NOTE: For dry bulb temperatures different than those listed (between 73-87 F), sensible capacity increases by 1060 BTUH per 1000 CFM per degree above the listed temperature and decreases by 1060 BTUH per 1000 CFM per degree below the listed temperature.

NOTE: KW RATING IS FOR OUTDOOR AND INDOOR UNITS.

HIGH CFM

Air Handler	Coil	T.C.	S.C.	KW
AV/SV60	—	1.00	0.99	1.00
F*FV060	—	1.00	0.99	1.00
MV20D	FC/MC60D	0.99	0.99	0.99

Variable Speed Furnace	Coil	T.C.	S.C.	KW
PV8*C20	FC/PC60C	0.99	0.99	1.01
P(C,V)9*D20	FC/PC60C	0.98	0.90	0.99
PV8*C20	FC/MC/PC60D	0.99	0.99	1.01
P(C,V)9*D20	FC/MC/PC60D	0.98	0.90	0.99
PV8*C20	MC61D	0.99	0.91	0.99
P(C,V)9*D20	MC61D	0.99	0.91	0.99
P(C,V)9*D20	HC60	0.98	0.90	1.00
PV8*C20	HD60	0.99	0.99	1.01
P(C,V)9*D20	HD60	0.99	0.99	1.01

NOTES

Subject to change without notice. Printed in U.S.A.
Copyright © by Unitary Products Group. 2008. All rights reserved.

246747-YTG-K-0208
Supersedes: 246747-YTG-J-0607

Unitary	5005	Norman
Products	York	OK
Group	Drive	73069