



**TECHNICAL GUIDE**

**AFFINITY  
SPLIT-SYSTEM HEAT PUMPS**

**15 SEER – R-410A**

**MODELS:**

**YZE024THRU 060  
(2 THRU 5 NOMINAL TONS)**

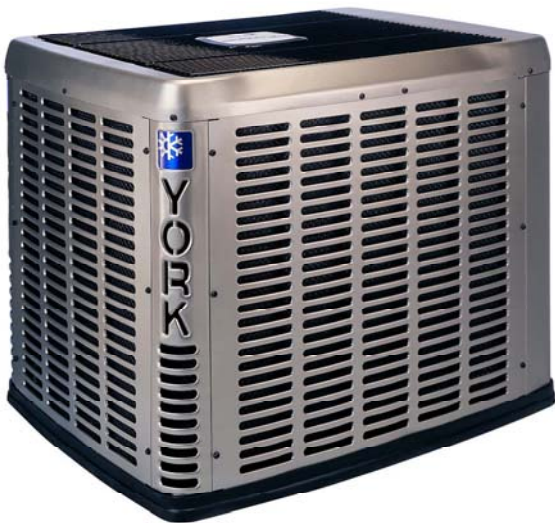

Due to continuous product improvement, specifications are subject to change without notice.

Visit us on the web at [www.york.com](http://www.york.com)

Additional rating information can be found at [www.ari.org/aridirectory](http://www.ari.org/aridirectory)

**DESCRIPTION**

The YZE Series unit is the outdoor part of a versatile heat pump system. It is designed to be custom matched with one of our complete line of evaporator sections, each designed to serve a specific function. Matching air handlers are available for upflow, downflow, and horizontal left or right application to provide a complete system. Electric heaters are available if required. Add-on coils are available for use with upflow, downflow, or horizontal furnaces. Field installed accessories are available as needed.

**WARRANTY**

*5-year limited parts warranty.*

*10-year limited compressor warranty.*

*Premium System Warranty - Limited lifetime compressor and 10-year parts when matched with an approved York Affinity furnace or UPG air handler and coil.*

**FEATURES**

- **Superior Coil Protection** – A stamped decorative metal coil guard completely protects coil from debris and other large damaging material while a polymer mesh further protects the coil against smaller particles.
- **Isolated Compressor Compartment** – A molded composite bulkhead isolates the compressor from the rest of the unit reducing sound and vibration.
- **Protected Compressors** – Each compressor is protected against high and low pressure as well as excessive temperature. This is accomplished by the simultaneous operation of a high pressure relief valve and temperature sensors which protect the compressor if undesirable conditions occur.
- **Environmentally Friendly Refrigerant** – Next generation refrigerant R-410A delivers environmentally friendly performance, with zero ozone depletion.
- **Durable Finish** – Automotive quality finish provides the ultimate protection from harmful U.V. rays as well as rust creep ensuring long-lasting high quality appearance. A powder-paint topcoat is applied over a baked-on primer, using a galvanized, zinc coated steel base material. The result is a finish that has been proven in testing to provide 33% greater durability than conventional powder-coat finishes.
- **Lower Installed Cost** – Designed to provide enhanced installability by featuring a slide-down control compartment allowing easy access to control components along with angled service valves to reduce overall installation time and cost.
- **Low Operating Sound Levels** – A fan design boasting technology adapted from aeronautic and defense engineering provides for whisper quiet operation by allowing airflow to flow smoothly and efficiently across the fan tips.
- **Filter-Drier** – A factory installed, solid core liquid line filter-drier filters harmful debris and moisture from the system.
- **Easy Service Access** – A full end, full service, access panel with handle makes for easy entry to internal components.
- **Long Lasting Operation** – Strong and durable composite base pan provides added strength while resisting rust and corrosion as well as reducing sound and vibration.
- **Quiet drive system** - The swept-wing fan, composite base pan, isolated compressor compartment and two-stage compressor are engineered as a system to reduce overall sound to a mere whisper.
- **Complete System Control** – All models utilize the exclusive microprocessor based, on-demand, defrost control system. This system provides optimal comfort, efficiency, and constant monitoring of the entire system for reliable operation. defrost cycles occur only when necessary. an adjustable balance point insures supplemental heat is brought on only when required to meet the space load, for optimum efficiency and reliability.
- In the event improper operating conditions occur (high temperature and/or high pressure), the unit will automatically shut down to protect the refrigeration system, and switch to back-up heat. On-board diagnostic LED's guide the technician to the source of the problem, and an output signal from the control to the thermostat will alert the homeowner. The control also features non-volatile memory, which preserves trouble codes in the event of power loss. An anti-short cycle timer extends the life of the compressor by preventing short-cycling.

Certified in accordance with the Unitary Small Equipment certification program, which is based on ARI Standard 210/240.

**Physical and Electrical Data**

| MODEL                                     |                   | YZE02411                  | YZE03611 | YZE04811 | YZE06011 |
|---|-------------------|---------------------------|----------|----------|----------|
| Unit Supply Voltage                       |                   | 208-230V, 1 $\phi$ , 60Hz |          |          |          |
| Normal Voltage Range <sup>1</sup>         |                   | 187 to 252                |          |          |          |
| Minimum Circuit Ampacity                  |                   | 18.6                      | 24.7     | 27.9     | 37.9     |
| Max. Overcurrent Device Amps <sup>2</sup> |                   | 30                        | 40       | 45       | 60       |
| Min. Overcurrent Device Amps <sup>3</sup> |                   | 20                        | 25       | 30       | 40       |
| Multi-stage Compressor                    |                   | Yes                       | Yes      | Yes      | Yes      |
| Compressor Type                           |                   | Scroll                    | Scroll   | Scroll   | Scroll   |
| Compressor Amps                           | Rated Load        | 13.7                      | 18.6     | 21.2     | 29.2     |
|   | Locked Rotor      | 52                        | 82       | 96       | 118      |
| Crankcase Heater                          |                   | No                        | No       | No       | No       |
| Fan Motor Amps                            | Rated Load        | 1.5                       | 1.5      | 1.5      | 1.5      |
| Fan Diameter Inches                       |                   | 22                        | 22       | 22       | 22       |
| Fan Motor                                 | Rated HP          | 1/4                       | 1/4      | 1/4      | 1/4      |
|   | Nominal RPM       | 850                       | 850      | 850      | 850      |
|   | Nominal CFM       | 3,250                     | 3,300    | 3,050    | 3,100    |
| Coil                                      | Face Area Sq. Ft. | 17.15                     | 20.58    | 20.58    | 20.58    |
|   | Rows Deep         | 1                         | 1        | 2        | 2        |
|   | Fins / Inch       | 22                        | 22       | 22       | 22       |
| Liquid Line Set OD (Field Installed)      |                   | 3/8                       | 3/8      | 3/8      | 3/8      |
| Vapor Line Set OD (Field Installed)       |                   | 3/4                       | 3/4      | 7/8      | 7/8      |
| Unit Charge (Lbs. - Oz.) <sup>4</sup>     |                   | 8 - 14                    | 8 - 8    | 14 - 8   | 14 - 0   |
| Charge Per Foot, Oz.                      |                   | 0.62                      | 0.62     | 0.67     | 0.75     |
| Operating Weight Lbs.                     |                   | 270                       | 290      | 310      | 315      |

1. Rated in accordance with ARI Standard 110, utilization range "A".
2. Dual element fuses or HACR circuit breaker. Maximum allowable overcurrent protection.
3. Dual element fuses or HACR circuit breaker. Minimum recommended overcurrent protection .
4. The Unit Charge is correct for the outdoor unit, matched indoor coil and 15 feet of refrigerant tubing. For tubing lengths other than 15 feet, add or subtract the amount of refrigerant, using the difference in length multiplied by the per foot value.

All dimensions are in inches. They are subject to change without notice. Certified dimensions will be provided upon request.

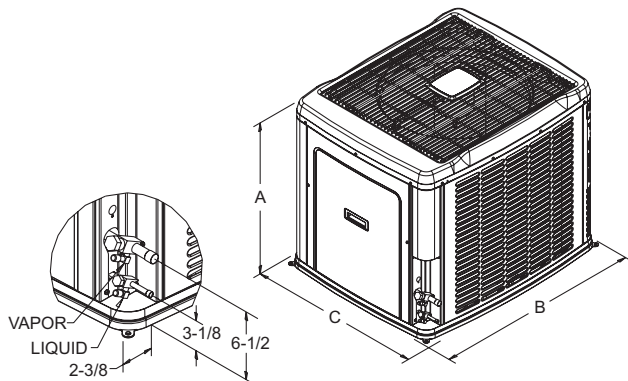

| Unit Model | Dimensions (Inches) |    |    | Refrigerant Connection Service Valve Size |       |
|------------|---------------------|----|----|---|-------|
|            | A                   | B  | C  | Liquid                                    | Vapor |
| 024        | 33-1/2              | 37 | 31 | 3/8"                                      | 3/4"  |
| 036        | 39-1/2              | 37 | 31 |   | 7/8"  |
| 048        | 39-1/2              | 37 | 31 |   | 7/8"  |
| 060        | 39-1/2              | 37 | 31 |   | 7/8"  |

\* Adapter fitting required for 1-1/8" line set.

**Additional R-410A Charge / TXV Size for Various Matched Systems**

| Outdoor Unit   | YZE02411                                     | YZE03611           | YZE04811 | YZE06011 |
|--|--|--------------------|----------|----------|
| Approved System Thermal Expansion Valve <sup>1</sup> | 1TVM902                                      | 1TVM902<br>1TVM4A1 | 1TVM905  | 1TVM906  |
| Factory R-410A Charge, lbs-oz                        | 8 - 14                                       | 8 - 8              | 14 - 8   | 14 - 0   |
| Indoor Coil <sup>2</sup>                             | TXV Kit <sup>3</sup> - Additional Charge, Oz |                    |          |          |
| FC/MC/PC/UC30A                                       | + 4  | -                  | -        | -        |
| FC/MC/PC/UC30B                                       | + 4  | -                  | -        | -        |
| FC/MC/PC32A  | + 6  | -                  | -        | -        |
| FC/MC/PC35B  | + 6  | + 0                | -        | -        |
| FC/MC/PC35C  | + 6  | + 0                | -        | -        |
| FC/MC/PC/UC36A                                       | + 5  | -                  | -        | -        |
| FC/MC/PC/UC36B                                       | + 5  | -                  | -        | -        |
| FC/MC/PC36C  | + 5  | -                  | -        | -        |
| FC/MC/PC/UC42B                                       | + 12   | + 0                | -        | -        |
| FC/MC/PC/UC42C                                       | + 12   | + 0                | -        | -        |
| FC/MC/PC/UC48C                                       | -  | + 14               | -        | -        |
| FC/MC/PC/UC48D                                       | -  | + 14               | -        | -        |
| FC/PC/UC60C  | -  | -                  | + 9      | + 9      |
| FC/MC/PC/UC60D                                       | -  | -                  | + 9      | + 9      |
| FC/MC62D   | -  | -                  | + 17     | + 16     |
| HC30   | + 4  | -                  | -        | -        |
| HC36   | + 6  | -                  | -        | -        |
| HC42   | -  | + 12               | -        | -        |
| HC60   | -  | -                  | + 9      | + 9      |
| HD24   | -  | -                  | -        | -        |
| HD36   | + 6  | -                  | -        | -        |
| HD48   | -  | + 10               | -        | -        |
| HD60   | -  | -                  | + 9      | + 9      |
| AV24   | + 4  | -                  | -        | -        |
| AV36   | + 12   | + 0                | -        | -        |
| AV/SV48  | -  | + 17               | + 9      | -        |
| AV/SV60  | -  | -                  | + 9      | + 9      |
| F*FV060  | -  | -                  | + 9      | + 9      |

**FOOTNOTES:**

1. Systems matched with furnace or air handlers not equipped with blower-off delays may require blower Time Delay Kit 2FD06700224.
2. PC coils cannot be used in downflow or horizontal applications. FC coils cannot be used in horizontal applications.
3. A TXV kit must be used with these coils to obtain system performance.  
Note: If a TXV is factory installed on the coil, it must be replaced with the listed TXV.

**PROCEDURES:**

1. Unit factory charge listed on the unit nameplate includes refrigerant for the condenser, the smallest evaporator and 15 feet of interconnecting line tubing.
2. Verify the TXV and additional charge required for specific evaporator coil in the system using the above table.
3. Additional charge for the amount of interconnecting line tubing greater than 15 feet at the rate specified in the Physical and Electrical Data Table.
4. Permanently mark the unit nameplate with the total system charge. Total System Charge = Base Charge (as shipped) + adder for evaporator + adder for line set.

**COOLING CAPACITY - With Air Handler Coils**

| UNIT MODEL | AIR HANDLER |    | COIL <sup>1</sup><br>MODEL | COOLING |              |            |              |       |       |
|------------|-------------|----|----------------------------|---------|--------------|------------|--------------|-------|-------|
|            | MODEL       | W  |                            | STAGE   | RATED<br>CFM | NET<br>MBH | SENSIBL<br>E | SEER  | EER   |
| YZE02411   | AV24        | 17 | -                          | 1       | 535          | 18.6       | 13.6         | 15.00 | 13.00 |
|            |             |    |                            | 2       | 800          | 24.0       | 18.6         |       | 12.50 |
|            | AV36        | 17 | -                          | 1       | 535          | 18.6       | 13.6         | 15.00 | 13.00 |
|            |             |    |                            | 2       | 800          | 24.0       | 18.6         |       | 12.50 |
|            | MV12B       | 17 | FC/MC30B                   | 1       | 620          | 18.6       | 13.6         | 14.25 | 12.00 |
|            |             |    |                            | 2       | 800          | 24.0       | 18.6         |       | 11.50 |
|            | MV12B       | 17 | FC/MC35B                   | 1       | 650          | 18.1       | 14.4         | 15.00 | 12.15 |
|            |             |    |                            | 2       | 775          | 24.0       | 19.6         |       | 12.00 |
|            | MV16C       | 21 | FC/MC35C                   | 1       | 650          | 18.6       | 13.6         | 15.00 | 13.00 |
|            |             |    |                            | 2       | 775          | 24.0       | 18.6         |       | 12.50 |
|            | MV12B       | 17 | FC/MC36B                   | 1       | 620          | 18.6       | 13.6         | 15.00 | 11.50 |
|            |             |    |                            | 2       | 800          | 24.6       | 18.6         |       | 12.00 |
|            | MV12B       | 17 | FC/MC42B                   | 1       | 650          | 18.1       | 14.4         | 15.00 | 12.15 |
|            |             |    |                            | 2       | 775          | 23.6       | 19.6         |       | 12.00 |
|            | MV16C       | 21 | FC/MC42C                   | 1       | 650          | 18.6       | 13.6         | 15.00 | 13.00 |
|            |             |    |                            | 2       | 775          | 24.0       | 18.6         |       | 12.50 |
| YZE03611   | AV36        | 17 | -                          | 1       | 830          | 25.0       | 17.5         | 15.75 | 12.70 |
|            |             |    |                            | 2       | 1200         | 35.4       | 24.2         |       | 12.00 |
|            | AV48        | 24 | -                          | 1       | 830          | 25.0       | 17.5         | 15.75 | 12.70 |
|            |             |    |                            | 2       | 1200         | 35.4       | 24.2         |       | 12.00 |
|            | MV12B       | 17 | FC/MC35B                   | 1       | 775          | 24.4       | 17.2         | 14.75 | 12.55 |
|            |             |    |                            | 2       | 1200         | 34.0       | 23.9         |       | 11.50 |
|            | MV12B       | 17 | FC/MC42B                   | 1       | 775          | 24.4       | 17.2         | 14.75 | 12.55 |
|            |             |    |                            | 2       | 1200         | 34.0       | 23.9         |       | 11.50 |
|            | MV16C       | 21 | FC/MC48C                   | 1       | 775          | 25.0       | 17.5         | 15.00 | 12.85 |
|            |             |    |                            | 2       | 1200         | 35.4       | 24.2         |       | 12.00 |
|            | MV12D       | 24 | FC/MC48D                   | 1       | 775          | 24.8       | 17.5         | 15.75 | 12.70 |
|            |             |    |                            | 2       | 1200         | 35.4       | 24.2         |       | 12.00 |
| YZE04811   | AV48        | 24 | -                          | 1       | 1135         | 33.2       | 23.5         | 15.00 | 13.30 |
|            |             |    |                            | 2       | 1600         | 45.0       | 32.8         |       | 12.50 |
|            | AV/SV*60    | 24 | -                          | 1       | 1135         | 33.2       | 23.5         | 15.00 | 13.30 |
|            |             |    |                            | 2       | 1600         | 45.0       | 32.8         |       | 12.50 |
|            | F*FV060     | 24 | -                          | 1       | 1000         | 33.2       | 23.5         | 15.50 | 13.10 |
|            |             |    |                            | 2       | 1600         | 46.0       | 32.8         |       | 12.15 |
|            | MV20D       | 24 | FC/MC60D                   | 1       | 1000         | 33.2       | 23.5         | 15.50 | 13.05 |
|            |             |    |                            | 2       | 1600         | 46.0       | 34.4         |       | 12.00 |
|            | MV20D       | 24 | FC/MC62D                   | 1       | 1000         | 33.4       | 23.7         | 15.50 | 13.20 |
|            |             |    |                            | 2       | 1600         | 47.0       | 34.7         |       | 12.00 |
| YZE06011   | AV60        | 24 | -                          | 1       | 1145         | 38.5       | 27.0         | 13.50 | 11.55 |
|            |             |    |                            | 2       | 1800         | 53.5       | 38.5         |       | 10.25 |
|            | F*FV060     | 24 | -                          | 1       | 1200         | 38.0       | 27.0         | 13.75 | 11.55 |
|            |             |    |                            | 2       | 1900         | 53.0       | 38.5         |       | 10.20 |
|            | MV20D       | 24 | FC/MC60D                   | 1       | 1200         | 38.0       | 27.0         | 13.75 | 11.50 |
|            |             |    |                            | 2       | 1900         | 53.0       | 38.5         |       | 11.00 |
|            | MV20D       | 24 | FC/MC62D                   | 1       | 1175         | 38.0       | 26.9         | 14.00 | 11.65 |
|            |             |    |                            | 2       | 1800         | 54.0       | 38.9         |       | 10.40 |

Rated in accordance with DOE test procedures (Federal Register 12-27-79 and 3-18-88) and ARI Standards 210.

Cooling MBH based on 80°F entering air temperature, 50% RH, and rated air flow.

EER (Energy Efficiency Ratio) is the total cooling output in BTU's at 95°F outdoor ambient divided by the total electric power in watt-hours at those conditions.  
SEER (Seasonal Energy Efficiency Ratio) is the total cooling output in BTU's during a normal annual usage period for cooling divided by the total electric power input in watt-hours during the same period.

1. G2FD coils available with a factory installed horizontal drain pan. See price pages for specific model number.

## COOLING CAPACITY - With Variable Speed Furnaces

| UNIT MODEL  | VARIABLE SPEED FURNACE MODEL | COIL MODEL <sup>1</sup> | W  | COOLING |           |         |          |       |       |
|-------------|------------------------------|-------------------------|----|---------|-----------|---------|----------|-------|-------|
|             |                              |                         |    | STAGE   | RATED CFM | NET MBH |          | SEER  | EER   |
|             |                              |                         |    |         |           | TOTAL   | SENSIBLE |       |       |
| YZE02411    | PV8*A12                      | FC/MC/PC/UC30A          | 14 | 1       | 430       | 17.3    | 11.5     | 14.00 | 12.60 |
|             |                              |                         |    | 2       | 750       | 23.0    | 18.2     |       | 12.00 |
|             | PV9*A12                      | FC/MC/PC30A             | 14 | 1       | 625       | 18.5    | 14.4     | 14.25 | 12.35 |
|             |                              |                         |    | 2       | 800       | 23.6    | 19.0     |       | 12.00 |
|             | P(C,V)9*B12                  | FC/MC/PC/UC30B          | 17 | 1       | 425       | 17.5    | 12.5     | 14.25 | 12.60 |
|             |                              |                         |    | 2       | 800       | 23.6    | 19.0     |       | 12.00 |
|             | PV9*A12                      | FC/MC/PC32A             | 14 | 1       | 425       | 17.4    | 11.6     | 14.75 | 12.00 |
|             |                              |                         |    | 2       | 800       | 24.0    | 19.0     |       | 11.50 |
|             | P(C,V)9*B12                  | FC/MC/PC35B             | 17 | 1       | 430       | 17.4    | 11.6     | 14.50 | 12.75 |
|             |                              |                         |    | 2       | 800       | 24.0    | 19.0     |       | 12.00 |
|             | PV8*A12                      | FC/MC/PC/UC36A          | 14 | 1       | 560       | 18.4    | 13.7     | 14.50 | 12.45 |
|             |                              |                         |    | 2       | 800       | 24.0    | 19.0     |       | 12.00 |
|             | PV9*A12                      | FC/MC/PC36A             | 17 | 1       | 560       | 18.4    | 13.7     | 14.50 | 12.45 |
|             |                              |                         |    | 2       | 800       | 24.0    | 19.0     |       | 12.00 |
| P(C,V)9*B12 | FC/MC/PC/UC36B               | 17                      | 1  | 560     | 18.4      | 13.7    | 14.50    | 12.45 |       |
|             |                              |                         | 2  | 800     | 24.0      | 19.0    |          | 12.00 |       |
| P(C,V)9*B12 | FC/MC/PC/UC42B               | 17                      | 1  | 640     | 18.2      | 14.4    | 14.75    | 12.05 |       |
|             |                              |                         | 2  | 800     | 24.0      | 19.0    |          | 12.00 |       |
| P(C,V)9*B12 | HC30                         | 17                      | 1  | 640     | 18.2      | 14.4    | 14.75    | 12.05 |       |
|             |                              |                         | 2  | 800     | 24.0      | 19.0    |          | 12.00 |       |
| P(C,V)9*B12 | HC36                         | 17                      | 1  | 475     | 17.4      | 12.0    | 14.50    | 12.60 |       |
|             |                              |                         | 2  | 800     | 24.0      | 19.0    |          | 12.00 |       |
| P(C,V)9*B12 | HD36                         | 17                      | 1  | 475     | 17.9      | 12.2    | 14.50    | 12.75 |       |
|             |                              |                         | 2  | 800     | 24.0      | 19.2    |          | 12.00 |       |
| YZE03611    | P(C,V)9*B12                  | FC/MC/PC35B             | 17 | 1       | 770       | 24.2    | 16.2     | 14.50 | 12.50 |
|             |                              |                         |    | 2       | 1200      | 32.2    | 23.1     |       | 12.00 |
|             | PV8*B16                      | FC/MC/PC35B             | 17 |         | 770       | 24.2    | 16.2     | 14.75 | 12.50 |
|             |                              |                         |    |         | 1200      | 32.2    | 23.1     |       | 12.00 |
|             | P(C,V)9*C16                  | FC/MC/PC35C             | 21 | 1       | 640       | 24.2    | 16.2     | 15.00 | 12.70 |
|             |                              |                         |    | 2       | 1200      | 32.2    | 23.1     |       | 12.00 |
|             | PV8*C16                      | FC/MC/PC35C             | 21 | 1       | 640       | 24.2    | 16.2     | 14.75 | 12.50 |
|             |                              |                         |    | 2       | 1200      | 32.2    | 23.1     |       | 12.00 |
|             | PV8*C20                      | FC/MC/PC35C             | 21 | 1       | 640       | 24.2    | 16.2     | 15.00 | 12.50 |
|             |                              |                         |    | 2       | 1200      | 32.2    | 23.1     |       | 12.00 |
|             | P(C,V)9*C20                  | FC/MC/PC35C             | 21 | 1       | 640       | 24.2    | 16.2     | 15.00 | 12.50 |
|             |                              |                         |    | 2       | 1200      | 32.2    | 23.1     |       | 12.00 |
|             | P(C,V)9*B12                  | FC/MC/PC/UC42B          | 17 | 1       | 770       | 24.6    | 18.4     | 14.50 | 12.45 |
|             |                              |                         |    | 2       | 1200      | 32.2    | 26.3     |       | 11.40 |
| PV8*B16     | FC/MC/PC/UC42B               | 17                      | 1  | 770     | 24.6      | 18.4    | 14.75    | 12.45 |       |
|             |                              |                         | 2  | 1200    | 32.2      | 26.3    |          | 11.40 |       |
| P(C,V)9*C20 | FC/MC/PC/UC42C               | 21                      | 1  | 640     | 24.6      | 18.4    | 15.00    | 12.50 |       |
|             |                              |                         | 2  | 1200    | 32.2      | 26.3    |          | 12.00 |       |
| P(C,V)9*C16 | FC/MC/PC/UC42C               | 21                      | 1  | 640     | 24.2      | 16.2    | 15.00    | 12.70 |       |
|             |                              |                         | 2  | 1200    | 32.2      | 23.1    |          | 11.50 |       |
| PV8*C16     | FC/MC/PC/UC42C               | 21                      | 1  | 780     | 25.0      | 18.9    | 15.00    | 12.85 |       |
|             |                              |                         | 2  | 1200    | 32.2      | 23.1    |          | 11.50 |       |
| PV8*C20     | FC/MC/PC/UC42C               | 21                      | 1  | 640     | 24.2      | 16.2    | 14.75    | 12.70 |       |
|             |                              |                         | 2  | 1200    | 32.2      | 23.1    |          | 11.50 |       |
| P(C,V)9*C20 | FC/MC/PC/UC48C               | 21                      | 1  | 640     | 24.2      | 16.2    | 15.25    | 12.70 |       |
|             |                              |                         | 2  | 1200    | 35.2      | 25.1    |          | 12.00 |       |

For Notes, See Page 6.

**COOLING CAPACITY - With Variable Speed Furnaces (Continued)**

| UNIT MODEL  | VARIABLE SPEED FURNACE MODEL | COIL MODEL <sup>1</sup> | W  | COOLING |           |         |          |       |       |
|-------------|------------------------------|-------------------------|----|---------|-----------|---------|----------|-------|-------|
|             |                              |                         |    | STAGE   | RATED CFM | NET MBH |          | SEER  | EER   |
|             |                              |                         |    |         |           | TOTAL   | SENSIBLE |       |       |
| YZE03611    | P(C,V)9*C16                  | FC/MC/PC/UC48C          | 21 | 1       | 640       | 24.2    | 16.2     | 15.50 | 12.70 |
|             |                              |                         |    | 2       | 1200      | 35.2    | 25.1     |       | 12.00 |
|             | PV8*C16                      | FC/MC/PC/UC48C          | 21 | 1       | 780       | 25.0    | 18.9     | 15.00 | 12.85 |
|             |                              |                         |    | 2       | 1200      | 34.8    | 26.8     |       | 12.00 |
|             | PV8*C20                      | FC/MC/PC/UC48C          | 21 | 1       | 800       | 25.2    | 19.1     | 15.25 | 12.90 |
|             |                              |                         |    | 2       | 1200      | 35.0    | 26.8     |       | 12.00 |
|             | P(C,V)9*D20                  | FC/MC/PC/UC48D          | 24 | 1       | 770       | 25.0    | 18.8     | 15.50 | 12.85 |
|             |                              |                         |    | 2       | 1200      | 35.0    | 26.8     |       | 12.00 |
|             | PV8*C16                      | HC42                    | 21 | 1       | 675       | 24.2    | 16.5     | 14.75 | 12.45 |
|             |                              |                         |    | 2       | 1200      | 32.2    | 25.1     |       | 11.50 |
|             | PV8*C20                      | HC42                    | 21 | 1       | 675       | 24.2    | 16.5     | 15.00 | 12.45 |
|             |                              |                         |    | 2       | 1200      | 32.2    | 25.1     |       | 11.50 |
| YZE04811    | PV8*C20                      | FC/MC/PC/UC60C          | 21 | 1       | 860       | 32.4    | 22.0     | 15.25 | 12.90 |
|             |                              |                         |    | 2       | 1600      | 46.0    | 35.2     |       | 12.00 |
|             | P(C,V)9*C20                  | FC/MC/PC/UC60C          | 21 | 1       | 1010      | 33.2    | 25.3     | 15.00 | 12.70 |
|             |                              |                         |    | 2       | 1600      | 45.5    | 36.8     |       | 11.75 |
|             | P(C,V)9*D20                  | FC/MC/PC/UC60D          | 24 | 1       | 1020      | 33.2    | 25.5     | 15.25 | 12.85 |
|             |                              |                         |    | 2       | 1600      | 46.0    | 36.8     |       | 11.50 |
|             | P(C,V)9*D20                  | FC/MC62D                | 24 | 1       | 1020      | 33.2    | 25.5     | 15.25 | 12.85 |
|             |                              |                         |    | 2       | 1600      | 46.0    | 36.8     |       | 11.50 |
|             | P(C,V)9*D20                  | HC60                    | 24 | 1       | 850       | 32.2    | 21.9     | 15.00 | 12.75 |
|             |                              |                         |    | 2       | 1610      | 45.5    | 35.2     |       | 11.50 |
|             | PV8*C20                      | HC60                    | 21 | 1       | 850       | 32.2    | 21.9     | 15.00 | 12.75 |
|             |                              |                         |    | 2       | 1610      | 45.5    | 35.2     |       | 11.50 |
| P(C,V)9*D20 | HD60                         | 24                      | 1  | 850     | 32.0      | 21.6    | 15.00    | 12.50 |       |
|             |                              |                         | 2  | 1610    | 45.5      | 34.5    |          | 11.50 |       |
| YZE06011    | PV8*C20                      | FC/MC/PC/UC60C          | 21 | 1       | 1030      | 37.4    | 25.4     | 13.50 | 11.30 |
|             |                              |                         |    | 2       | 1730      | 53.0    | 38.1     |       | 11.00 |
|             | P(C,V)9*C20                  | FC/MC/PC/UC60C          | 21 | 1       | 1040      | 37.4    | 27.4     | 13.25 | 11.25 |
|             |                              |                         |    | 2       | 1620      | 52.5    | 39.9     |       | 11.00 |
|             | P(C,V)9*D20                  | FC/MC/PC/UC60D          | 24 | 1       | 1030      | 37.4    | 27.3     | 13.50 | 11.30 |
|             |                              |                         |    | 2       | 1620      | 52.5    | 40.0     |       | 11.00 |
|             | P(C,V)9*D20                  | FC/MC62D                | 24 | 1       | 1030      | 37.4    | 27.3     | 13.50 | 11.30 |
|             |                              |                         |    | 2       | 1620      | 52.5    | 40.0     |       | 11.00 |
|             | P(C,V)9*D20                  | HC60                    | 24 | 1       | 1010      | 37.2    | 25.1     | 13.50 | 11.20 |
|             |                              |                         |    | 2       | 1610      | 52.5    | 36.8     |       | 11.00 |
|             | PV8*C20                      | HD60                    | 21 | 1       | 1010      | 36.8    | 24.8     | 13.50 | 11.10 |
|             |                              |                         |    | 2       | 1610      | 51.5    | 36.0     |       | 11.00 |
| P(C,V)9*D20 | HD60                         | 24                      | 1  | 1010    | 36.8      | 24.8    | 13.50    | 11.10 |       |
|             |                              |                         | 2  | 1610    | 51.5      | 36.0    |          | 11.00 |       |

1. MC coils available with a factory installed horizontal drain pan. See price pages for specific model number.

**HEATING CAPACITY - With Air Handler Coils**

| UNIT MODEL | AIR HANDLER MODEL | COIL <sup>1</sup> MODEL | HEATING |           |         |       |      |          |
|------------|-------------------|-------------------------|---------|-----------|---------|-------|------|----------|
|            |                   |                         | STAGE   | RATED CFM | NET MBH |       | HSPF | COP @ 47 |
|            |                   |                         |         |           | 47 OD   | 17 OD |      |          |
| YZE02411   | AV24              | -                       | 1       | 650       | 19.0    | -     | -    | 3.30     |
|            |                   |                         | 2       | 775       | 24.0    | 15.6  | 8.25 | 3.36     |
|            |                   |                         | 2       | 650       | 23.2    | 14.6  | 8.05 | 3.12     |
|            | AV36              | -                       | 1       | 650       | 19.0    | -     | -    | 3.30     |
|            |                   |                         | 2       | 775       | 24.0    | 15.6  | 8.25 | 3.36     |
|            |                   |                         | 2       | 650       | 23.2    | 14.6  | 8.05 | 3.12     |
|            | MV12B             | FC/MC30B                | 1       | 620       | 19.0    | -     | -    | 3.30     |
|            |                   |                         | 2       | 800       | 24.0    | 15.6  | 8.10 | 3.36     |
|            |                   |                         | 2       | 620       | 23.2    | 14.6  | 8.00 | 3.12     |
|            | MV12B             | FC/MC35B                | 1       | 620       | 19.0    | -     | -    | 3.30     |
|            |                   |                         | 2       | 800       | 24.0    | 15.6  | 8.30 | 3.36     |
|            |                   |                         | 2       | 620       | 23.2    | 14.6  | 8.05 | 3.12     |
|            | MV16C             | FC/MC35C                | 1       | 620       | 19.0    | -     | -    | 3.30     |
|            |                   |                         | 2       | 800       | 24.0    | 15.6  | 8.20 | 3.36     |
|            |                   |                         | 2       | 620       | 23.2    | 14.6  | 8.05 | 3.12     |
|            | MV12B             | FC/MC36B                | 1       | 620       | 18.9    | -     | -    | 3.30     |
|            |                   |                         | 2       | 800       | 24.0    | 15.6  | 8.20 | 3.36     |
|            |                   |                         | 2       | 620       | 23.2    | 14.6  | 8.05 | 3.12     |
|            | MV12B             | FC/MC42B                | 1       | 650       | 18.9    | -     | -    | 3.30     |
|            |                   |                         | 2       | 775       | 24.0    | 15.5  | 8.30 | 3.36     |
|            |                   |                         | 2       | 650       | 23.0    | 14.5  | 8.05 | 3.12     |
| MV16C      | FC/MC42C          | 1                       | 650     | 18.9      | -       | -     | 3.30 |          |
|            |                   | 2                       | 775     | 24.0      | 15.5    | 8.2   | 3.36 |          |
|            |                   | 2                       | 650     | 23.0      | 14.5    | 8.05  | 3.12 |          |
| YZE03611   | AV36              | -                       | 1       | 775       | 23.6    | -     | -    | 3.60     |
|            |                   |                         | 2       | 1200      | 33.0    | 20.8  | 8.50 | 3.70     |
|            |                   |                         | 2       | 775       | 29.6    | 19.7  | 8.40 | 3.30     |
|            | AV48              | -                       | 1       | 775       | 23.6    | -     | -    | 3.60     |
|            |                   |                         | 2       | 1200      | 33.0    | 20.8  | 8.50 | 3.70     |
|            |                   |                         | 2       | 775       | 29.6    | 19.7  | 8.40 | 3.30     |
|            | MV12B             | FC/MC35B                | 1       | 775       | 23.6    | -     | -    | 3.60     |
|            |                   |                         | 2       | 1200      | 32.8    | 20.6  | 8.40 | 3.70     |
|            |                   |                         | 2       | 775       | 29.6    | 19.7  | 8.30 | 3.30     |
|            | MV12B             | FC/MC42B                | 1       | 775       | 23.6    | -     | -    | 3.60     |
|            |                   |                         | 2       | 1200      | 32.8    | 20.6  | 8.50 | 3.70     |
|            |                   |                         | 2       | 775       | 29.6    | 19.7  | 8.40 | 3.30     |
|            | MV16C             | FC/MC48C                | 1       | 775       | 23.6    | -     | -    | 3.60     |
|            |                   |                         | 2       | 1200      | 33.0    | 20.8  | 8.50 | 3.70     |
|            |                   |                         | 2       | 775       | 29.2    | 19.5  | 8.40 | 3.30     |
| MV12D      | FC/MC48D          | 1                       | 775     | 23.6      | -       | -     | 3.60 |          |
|            |                   | 2                       | 1200    | 33.0      | 20.8    | 8.50  | 3.70 |          |
|            |                   | 2                       | 775     | 29.2      | 19.5    | 8.40  | 3.30 |          |
| YZE04811   | AV48              | -                       | 1       | 1000      | 31.8    | -     | -    | 3.62     |
|            |                   |                         | 2       | 1600      | 48.0    | 27.6  | 8.80 | 3.96     |
|            |                   |                         | 2       | 1000      | 45.5    | 26.6  | 8.30 | 3.76     |
|            | AV/SV*60          | -                       | 1       | 1000      | 31.8    | -     | -    | 3.62     |
|            |                   |                         | 2       | 1600      | 48.0    | 27.4  | 8.40 | 3.96     |
|            |                   |                         | 2       | 1000      | 45.5    | 26.6  | 8.30 | 3.76     |
|            | F2FV060           | -                       | 1       | 1000      | 31.8    | -     | -    | 3.62     |
|            |                   |                         | 2       | 1600      | 47.5    | 27.4  | 8.80 | 3.96     |
|            |                   |                         | 2       | 1000      | 45.5    | 26.6  | 8.30 | 3.76     |
|            | MV20D             | FC/MC60D                | 1       | 1000      | 31.8    | -     | -    | 3.60     |
|            |                   |                         | 2       | 1600      | 48.0    | 27.6  | 8.80 | 3.96     |
|            |                   |                         | 2       | 1000      | 45.5    | 26.8  | 8.35 | 3.76     |
| MV20D      | FC/MC62D          | 1                       | 1000    | 31.8      | -       | -     | 3.62 |          |
|            |                   | 2                       | 1600    | 48.0      | 28.0    | 8.50  | 3.96 |          |
|            |                   | 2                       | 1000    | 45.5      | 26.6    | 8.30  | 3.76 |          |

For Notes, See Page 8.

**HEATING CAPACITY - With Air Handler Coils (Continued)**

| UNIT MODEL | AIR HANDLER MODEL | COIL <sup>1</sup> MODEL | HEATING |           |         |       |      |          |
|------------|-------------------|-------------------------|---------|-----------|---------|-------|------|----------|
|            |                   |                         | STAGE   | RATED CFM | NET MBH |       | HSPF | COP @ 47 |
|            |                   |                         |         |           | 47 OD   | 17 OD |      |          |
| YZE06011   | AV60              | -                       | 1       | 1200      | 37.6    | -     | -    | 3.26     |
|            |                   |                         | 2       | 1900      | 55.0    | 32.4  | 8.05 | 3.50     |
|            |                   |                         | 2       | 1200      | 50.0    | 29.8  | 7.90 | 3.22     |
|            | F2FV060           | -                       | 1       | 1200      | 37.6    | -     | -    | 3.26     |
|            |                   |                         | 2       | 1900      | 54.0    | 32.2  | 8.00 | 3.50     |
|            |                   |                         | 2       | 1200      | 50.0    | 29.8  | 7.90 | 3.22     |
|            | MV20D             | FC/MC60D                | 1       | 1200      | 37.6    | -     | -    | 3.26     |
|            |                   |                         | 2       | 1900      | 54.5    | 32.4  | 8.00 | 3.50     |
|            |                   |                         | 2       | 1200      | 50.0    | 30    | 7.90 | 3.22     |
|            | MV20D             | FC/MC62D                | 1       | 1175      | 37.6    | -     | -    | 3.26     |
|            |                   |                         | 2       | 1800      | 54.5    | 32.6  | 8.00 | 3.50     |
|            |                   |                         | 2       | 1175      | 50.0    | 29.6  | 7.85 | 3.22     |

Rated in accordance with DOE test procedures (Federal Register 12-27-79 and 3-18-88) and ARI Standards 210.

Cooling MBH based on 80°F entering air temperature, 50% RH, and rated air flow.

EER (Energy Efficiency Ratio) is the total cooling output in BTU's at 95°F outdoor ambient divided by the total electric power in watt-hours at those conditions.

SEER (Seasonal Energy Efficiency Ratio) is the total cooling output in BTU's during a normal annual usage period for cooling divided by the total electric power input in watt-hours during the same period.

1. MC coils available with a factory installed horizontal drain pan. See price pages for specific model number.

\*\* Refer to Quick Selection Chart for specific furnace match-up.

**HEATING CAPACITY - With Variable Speed Furnaces**

| UNIT MODEL  | VARIABLE SPEED FURNACE MODEL | COIL MODEL <sup>1</sup> | W  | HEATING |           |         |       |      |          |
|-------------|------------------------------|-------------------------|----|---------|-----------|---------|-------|------|----------|
|             |                              |                         |    | STAGE   | RATED CFM | NET MBH |       | HSPF | COP @ 47 |
|             |                              |                         |    |         |           | 47 OD   | 17 OD |      |          |
| YZE02411    | PV8*A12                      | FC/MC/PC/UC30A          | 14 | 1       | 430       | 18.1    | -     | -    | 3.16     |
|             |                              |                         |    | 2       | 800       | 24.0    | 15.3  | 8.10 | 3.36     |
|             |                              |                         |    | 2       | 430       | 22.8    | 14.4  | 8.00 | 3.10     |
|             | PV9*A12                      | FC/MC/PC30A             | 14 | 1       | 430       | 18.1    | -     | -    | 3.16     |
|             |                              |                         |    | 2       | 800       | 24.0    | 15.3  | 8.10 | 3.36     |
|             |                              |                         |    | 2       | 430       | 22.8    | 14.4  | 8.00 | 3.10     |
|             | P(C,V)9*B12                  | FC/MC/PC/UC30B          | 17 | 1       | 430       | 18.1    | -     | -    | 3.16     |
|             |                              |                         |    | 2       | 800       | 24.0    | 15.3  | 8.10 | 3.36     |
|             |                              |                         |    | 2       | 430       | 22.8    | 14.4  | 8.00 | 3.10     |
|             | PV9*A12                      | FC/MC/PC32A             | 14 | 1       | 430       | 18.1    | -     | -    | 3.16     |
|             |                              |                         |    | 2       | 800       | 24.0    | 15.3  | 8.10 | 3.36     |
|             |                              |                         |    | 2       | 430       | 22.8    | 14.4  | 8.00 | 3.10     |
|             | P(C,V)9*B12                  | FC/MC/PC35B             | 17 | 1       | 430       | 18.1    | -     | -    | 3.16     |
|             |                              |                         |    | 2       | 800       | 24.0    | 15.5  | 8.20 | 3.36     |
|             |                              |                         |    | 2       | 430       | 22.8    | 14.4  | 8.00 | 3.10     |
|             | PV8*A12                      | FC/MC/PC/UC36A          | 14 | 1       | 430       | 18.0    | -     | -    | 3.16     |
|             |                              |                         |    | 2       | 800       | 24.0    | 15.5  | 8.15 | 3.36     |
|             |                              |                         |    | 2       | 430       | 23.0    | 14.5  | 8.00 | 3.12     |
|             | PV9*A12                      | FC/MC/PC36A             | 14 | 1       | 425       | 18.0    | -     | -    | 3.16     |
|             |                              |                         |    | 2       | 800       | 24.0    | 15.5  | 8.20 | 3.36     |
|             |                              |                         |    | 2       | 425       | 23.0    | 14.5  | 8.00 | 3.12     |
|             | P(C,V)9*B12                  | FC/MC/PC/UC36B          | 17 | 1       | 425       | 18.0    | -     | -    | 3.16     |
|             |                              |                         |    | 2       | 800       | 24.0    | 15.5  | 8.20 | 3.36     |
|             |                              |                         |    | 2       | 425       | 23.0    | 14.5  | 8.00 | 3.12     |
|             | P(C,V)9*B12                  | FC/MC/PC/UC42B          | 17 | 1       | 430       | 18.1    | -     | -    | 3.16     |
|             |                              |                         |    | 2       | 800       | 24.0    | 15.5  | 8.20 | 3.34     |
|             |                              |                         |    | 2       | 430       | 23.0    | 14.4  | 8.00 | 3.12     |
|             | P(C,V)9*B12                  | HC30                    | 17 | 1       | 430       | 18.1    | -     | -    | 3.16     |
|             |                              |                         |    | 2       | 800       | 24.0    | 15.5  | 8.20 | 3.34     |
|             |                              |                         |    | 2       | 430       | 23.0    | 14.4  | 8.00 | 3.12     |
| P(C,V)9*B12 | HC36                         | 17                      | 1  | 425     | 18.0      | -       | -     | 3.16 |          |
|             |                              |                         | 2  | 800     | 24.0      | 15.5    | 8.20  | 3.36 |          |
|             |                              |                         | 2  | 425     | 23.0      | 14.5    | 8.00  | 3.12 |          |
| P(C,V)9*B12 | HD36                         | -                       | 1  | 425     | 18.0      | -       | -     | 3.16 |          |
|             |                              |                         | 2  | 800     | 24.0      | 15.5    | 8.20  | 3.36 |          |
|             |                              |                         | 2  | 425     | 23.0      | 14.5    | 8.00  | 3.12 |          |

For Notes, See Page 10.

## HEATING CAPACITY - With Variable Speed Furnaces (Continued)

| UNIT MODEL  | VARIABLE SPEED FURNACE MODEL | COIL MODEL <sup>1</sup> | W  | HEATING |           |         |       |      |          |
|-------------|------------------------------|-------------------------|----|---------|-----------|---------|-------|------|----------|
|             |                              |                         |    | STAGE   | RATED CFM | NET MBH |       | HSPF | COP @ 47 |
|             |                              |                         |    |         |           | 47 OD   | 17 OD |      |          |
| YZE03611    | P(C,V)9*B12                  | FC/MC/PC35B             | 17 | 1       | 650       | 23.0    | -     | -    | 3.54     |
|             |                              |                         |    | 2       | 1200      | 33.0    | 20.8  | 8.50 | 3.70     |
|             |                              |                         |    | 2       | 650       | 29.4    | 19.6  | 8.35 | 3.30     |
|             | PV8*B16                      | FC/MC/PC35B             | 17 | 1       | 650       | 23.0    | -     | -    | 3.54     |
|             |                              |                         |    | 2       | 1200      | 33.0    | 21.0  | 8.50 | 3.70     |
|             |                              |                         |    | 2       | 650       | 29.4    | 19.6  | 8.35 | 3.30     |
|             | P(C,V)9*C16                  | FC/MC/PC35C             | 21 | 1       | 650       | 23.0    | -     | -    | 3.54     |
|             |                              |                         |    | 2       | 1200      | 33.0    | 21.0  | 8.50 | 3.70     |
|             |                              |                         |    | 2       | 650       | 29.4    | 19.6  | 8.35 | 3.30     |
|             | PV8*C16                      | FC/MC/PC35C             | 21 | 1       | 650       | 23.0    | -     | -    | 3.54     |
|             |                              |                         |    | 2       | 1200      | 33.0    | 20.8  | 8.50 | 3.70     |
|             |                              |                         |    | 2       | 650       | 29.4    | 19.6  | 8.35 | 3.30     |
|             | PV8*C20                      | FC/MC/PC35C             | 21 | 1       | 650       | 23.0    | -     | -    | 3.54     |
|             |                              |                         |    | 2       | 1200      | 33.0    | 20.8  | 8.50 | 3.70     |
|             |                              |                         |    | 2       | 650       | 29.4    | 19.6  | 8.35 | 3.30     |
|             | P(C,V)9*C20                  | FC/MC/PC35C             | 21 | 1       | 650       | 23.0    | -     | -    | 3.54     |
|             |                              |                         |    | 2       | 1200      | 33.0    | 20.8  | 8.50 | 3.70     |
|             |                              |                         |    | 2       | 650       | 29.4    | 19.6  | 8.35 | 3.30     |
|             | P(C,V)9*B12                  | FC/MC/PC/UC42B          | 17 | 1       | 650       | 23.0    | -     | -    | 3.54     |
|             |                              |                         |    | 2       | 1200      | 33.0    | 20.8  | 8.50 | 3.70     |
|             |                              |                         |    | 2       | 650       | 29.4    | 19.6  | 8.35 | 3.30     |
|             | PV8*B16                      | FC/MC/PC/UC42B          | 17 | 1       | 660       | 23.2    | -     | -    | 3.56     |
|             |                              |                         |    | 2       | 1200      | 33.0    | 21.0  | 8.50 | 3.70     |
|             |                              |                         |    | 2       | 660       | 29.8    | 19.9  | 8.40 | 3.30     |
|             | P(C,V)9*C20                  | FC/MC/PC/UC42C          | 21 | 1       | 650       | 23.2    | -     | -    | 3.56     |
|             |                              |                         |    | 2       | 1200      | 33.0    | 20.8  | 8.50 | 3.70     |
|             |                              |                         |    | 2       | 650       | 29.8    | 19.9  | 8.40 | 3.30     |
|             | P(C,V)9*C16                  | FC/MC/PC/UC42C          | 21 | 1       | 650       | 23.2    | -     | -    | 3.56     |
|             |                              |                         |    | 2       | 1200      | 33.0    | 20.8  | 8.50 | 3.70     |
|             |                              |                         |    | 2       | 650       | 29.8    | 19.9  | 8.40 | 3.30     |
|             | PV8*C16                      | FC/MC/PC/UC42C          | 21 | 1       | 650       | 23.2    | -     | -    | 3.56     |
|             |                              |                         |    | 2       | 1200      | 33.0    | 21.0  | 8.50 | 3.70     |
|             |                              |                         |    | 2       | 650       | 29.8    | 19.9  | 8.40 | 3.30     |
|             | PV8*C20                      | FC/MC/PC/UC42C          | 21 | 1       | 650       | 23.2    | -     | -    | 3.56     |
|             |                              |                         |    | 2       | 1200      | 33.0    | 20.8  | 8.50 | 3.70     |
|             |                              |                         |    | 2       | 650       | 29.8    | 19.9  | 8.40 | 3.30     |
| P(C,V)9*C20 | FC/MC/PC/UC48C               | 21                      | 1  | 640     | 23.2      | -       | -     | 3.56 |          |
|             |                              |                         | 2  | 1200    | 33.0      | 20.8    | 8.50  | 3.70 |          |
|             |                              |                         | 2  | 640     | 29.4      | 19.5    | 8.35  | 3.30 |          |
| P(C,V)9*C16 | FC/MC/PC/UC48C               | 21                      | 1  | 640     | 23.0      | -       | -     | 3.54 |          |
|             |                              |                         | 2  | 1200    | 33.0      | 20.8    | 8.50  | 3.70 |          |
|             |                              |                         | 2  | 640     | 29.4      | 19.5    | 8.35  | 3.30 |          |
| PV8*C16     | FC/MC/PC/UC48C               | 21                      | 1  | 640     | 23.0      | -       | -     | 3.54 |          |
|             |                              |                         | 2  | 1200    | 33.0      | 21.0    | 8.50  | 3.70 |          |
|             |                              |                         | 2  | 640     | 29.4      | 19.6    | 8.35  | 3.30 |          |
| PV8*C20     | FC/MC/PC/UC48C               | 21                      | 1  | 640     | 23.0      | -       | -     | 3.54 |          |
|             |                              |                         | 2  | 1200    | 33.0      | 20.8    | 8.50  | 3.70 |          |
|             |                              |                         | 2  | 640     | 29.4      | 19.6    | 8.35  | 3.30 |          |
| P(C,V)9*D20 | FC/MC/PC/UC48D               | 24                      | 1  | 680     | 23.2      | -       | -     | 3.56 |          |
|             |                              |                         | 2  | 1220    | 33.0      | 21.0    | 8.50  | 3.70 |          |
|             |                              |                         | 2  | 680     | 29.6      | 19.7    | 8.35  | 3.30 |          |
| PV8*C16     | HC42                         | 21                      | 1  | 640     | 23.0      | -       | -     | 3.54 |          |
|             |                              |                         | 2  | 1200    | 33.0      | 21.0    | 8.50  | 3.70 |          |
|             |                              |                         | 2  | 640     | 29.4      | 19.5    | 8.35  | 3.30 |          |
| PV8*C20     | HC42                         | 21                      | 1  | 640     | 23.0      | -       | -     | 3.54 |          |
|             |                              |                         | 2  | 1200    | 33.0      | 20.8    | 8.50  | 3.70 |          |
|             |                              |                         | 2  | 640     | 29.4      | 19.5    | 8.35  | 3.30 |          |

For Notes, See Page 10.

**HEATING CAPACITY - With Variable Speed Furnaces (Continued)**

| UNIT MODEL  | VARIABLE SPEED FURNACE MODEL | COIL MODEL <sup>1</sup> | W  | HEATING |           |         |       |      |          |
|-------------|------------------------------|-------------------------|----|---------|-----------|---------|-------|------|----------|
|             |                              |                         |    | STAGE   | RATED CFM | NET MBH |       | HSPF | COP @ 47 |
|             |                              |                         |    |         |           | 47 OD   | 17 OD |      |          |
| YZE04811    | PV8*C20                      | FC/PC/UC60C             | 21 | 1       | 860       | 31.2    | -     | -    | 3.56     |
|             |                              |                         |    | 2       | 1610      | 48.0    | 27.8  | 8.35 | 3.96     |
|             |                              |                         |    | 2       | 860       | 44.5    | 26.2  | 8.30 | 3.66     |
|             | P(C,V)9*C20                  | FC/PC/UC60C             | 21 | 1       | 870       | 31.2    | -     | -    | 3.56     |
|             |                              |                         |    | 2       | 1590      | 48.0    | 27.8  | 8.40 | 3.96     |
|             |                              |                         |    | 2       | 870       | 44.5    | 26.2  | 8.30 | 3.66     |
|             | P(C,V)9*D20                  | FC/MC/PC/UC60D          | 24 | 1       | 855       | 31.2    | -     | -    | 3.56     |
|             |                              |                         |    | 2       | 1620      | 48.0    | 27.8  | 8.40 | 3.96     |
|             |                              |                         |    | 2       | 855       | 44.5    | 26.2  | 8.30 | 3.66     |
|             | P(C,V)9*D20                  | FC/MC62D                | 24 | 1       | 855       | 31.2    | -     | -    | 3.56     |
|             |                              |                         |    | 2       | 1620      | 48.0    | 27.8  | 8.40 | 3.96     |
|             |                              |                         |    | 2       | 855       | 44.5    | 26.2  | 8.30 | 3.66     |
|             | P(C,V)9*D20                  | HC60                    | 24 | 1       | 855       | 31.2    | -     | -    | 3.56     |
|             |                              |                         |    | 2       | 1620      | 48.0    | 27.8  | 8.40 | 3.96     |
|             |                              |                         |    | 2       | 855       | 44.5    | 26.2  | 8.30 | 3.66     |
|             | PV8*C20                      | HC60                    | 21 | 1       | 855       | 31.2    | -     | -    | 3.56     |
|             |                              |                         |    | 2       | 1620      | 48.0    | 27.8  | 8.40 | 3.96     |
|             |                              |                         |    | 2       | 855       | 44.5    | 26.2  | 8.30 | 3.66     |
| P(C,V)9*D20 | HD60                         | 24                      | 1  | 855     | 31.2      | -       | -     | 3.56 |          |
|             |                              |                         | 2  | 1620    | 48.0      | 27.8    | 8.35  | 3.96 |          |
|             |                              |                         | 2  | 855     | 44.5      | 26.2    | 8.30  | 3.66 |          |
| YZE06011    | PV8*C20                      | FC/PC/UC60C             | 21 | 1       | 1030      | 37.0    | -     | -    | 3.22     |
|             |                              |                         |    | 2       | 1730      | 54.5    | 32.0  | 8.05 | 3.48     |
|             |                              |                         |    | 2       | 1030      | 49.5    | 29.6  | 7.85 | 3.20     |
|             | P(C,V)9*C20                  | FC/PC/UC60C             | 21 | 1       | 990       | 36.8    | -     | -    | 3.20     |
|             |                              |                         |    | 2       | 1640      | 54.5    | 31.6  | 8.00 | 3.46     |
|             |                              |                         |    | 2       | 990       | 49.5    | 29.2  | 7.80 | 3.18     |
|             | P(C,V)9*D20                  | FC/MC/PC/UC60D          | 24 | 1       | 990       | 36.8    | -     | -    | 3.20     |
|             |                              |                         |    | 2       | 1620      | 54.0    | 31.4  | 8.00 | 3.46     |
|             |                              |                         |    | 2       | 990       | 49.0    | 29.0  | 7.75 | 3.16     |
|             | P(C,V)9*D20                  | FC/MC62D                | 24 | 1       | 990       | 36.8    | -     | -    | 3.20     |
|             |                              |                         |    | 2       | 1620      | 54.0    | 31.4  | 8.00 | 3.48     |
|             |                              |                         |    | 2       | 990       | 49.0    | 29.0  | 7.75 | 3.16     |
|             | P(C,V)9*D20                  | HC60                    | 24 | 1       | 990       | 36.8    | -     | -    | 3.20     |
|             |                              |                         |    | 2       | 1620      | 54.0    | 31.4  | 8.00 | 3.46     |
|             |                              |                         |    | 2       | 990       | 49.0    | 29.0  | 7.75 | 3.16     |
|             | PV8*C20                      | HD60                    | 21 | 1       | 990       | 36.8    | -     | -    | 3.20     |
|             |                              |                         |    | 2       | 1620      | 54.0    | 31.4  | 8.00 | 3.46     |
|             |                              |                         |    | 2       | 990       | 49.0    | 29.0  | 7.75 | 3.16     |
| P(C,V)9*D20 | HD60                         | 24                      | 1  | 990     | 36.8      | -       | -     | 3.20 |          |
|             |                              |                         | 2  | 1620    | 54.0      | 31.4    | 8.00  | 3.46 |          |
|             |                              |                         | 2  | 990     | 49.0      | 29.0    | 7.75  | 3.16 |          |

1. MC coils available with a factory installed horizontal drain pan. See price pages for specific model number.

**ACCESSORIES\***

**TXV Kits** - 1TVM9 series thermal expansion valves precisely meter refrigerant for optimum performance.

**Bonnet Sensor (2SB13700124)** - The bonnet sensor is used to sense plenum temperature, and is optional with a gas or oil back-up heat source. Compatible only with 13 SEER and higher heat pumps.

**Dehumidistat (2HU16700124)** - Provides increased dehumidification when matched with variable speed furnace or air handler.

**Heat Pump Risers** - (526-35389-000, 526-35390-000, 526-35391-000) - 3", 6", or 12" risers mount easily in composite base pan recesses, ensuring the unit stays clear of snow and ice build-up in harsh winter weather.

**Room Thermostats** - A wide selection of matching thermostats is available to provide features required for any installation.

3H/2C, non-programmable digital thermostat.

3H/2C, auto/manual changeover, electronic programmable, 7-day, thermostat.

\* For the most current accessory information, refer to the price book or consult factory.

**SOUND POWER RATINGS\***

| UNIT MODEL | (dBA)   |         |
|------------|---------|---------|
|            | Cooling | Heating |
| 024        | 71      | 72      |
| 036        | 72      | 73      |
| 048        | 72      | 73      |
| 060        | 73      | 74      |

\* Rated in accordance with ARI 270-95 Standards.

**COLOR GRILLES**

| CHOICE OF SEVERAL COLOR COIL GRILLES TO COMPLIMENT ANY HOME. |                   |                    |
|--|-------------------|--------------------|
| Color Grill  | Color Description |                    |
| 1CP0130  | Terra Cotta       | 024                |
| 1CP0136  | Terra Cotta       | 036, 038, 048, 060 |
| 1CP0230  | Jet Black         | 024                |
| 1CP0236  | Jet Black         | 036, 038, 048, 060 |
| 1CP0330  | Stone             | 024                |
| 1CP0336  | Stone             | 036, 048, 060      |
| 1CP0430  | Bermuda           | 024                |
| 1CP0436  | Bermuda           | 036, 038, 048, 060 |
| 1CP0530  | Gunmetal          | 024                |
| 1CP0536  | Gunmetal          | 036, 038, 048, 060 |
| 1CP0630  | Chocolate         | 024                |
| 1CP0636  | Chocolate         | 036, 038, 048, 060 |

| <b>COOLING PERFORMANCE DATA - LOW CFM 1-STAGE OPERATION</b> |                   |                         |      |      |      |      |            |      |      |      |      |            |      |      |      |      |
|---|-------------------|-------------------------|------|------|------|------|------------|------|------|------|------|------------|------|------|------|------|
| <b>OUTDOOR UNIT MODEL NO.</b>                               |                   | <b>YZE02411</b>         |      |      |      |      |            |      |      |      |      |            |      |      |      |      |
| <b>INDOOR COIL MODEL NO.</b>                                |                   | <b>FC/MC36B + MV12B</b> |      |      |      |      |            |      |      |      |      |            |      |      |      |      |
| <b>CONDENSER<br/>ENTERING AIR<br/>TEMPERATURE</b>           | <b>ID CFM</b>     | <b>550</b>              |      |      |      |      | <b>600</b> |      |      |      |      | <b>650</b> |      |      |      |      |
|   | <b>ID DB (°F)</b> | 80                      | 80   | 75   | 80   | 80   | 80         | 80   | 75   | 80   | 80   | 80         | 80   | 75   | 80   | 80   |
|   | <b>ID WB (°F)</b> | 57                      | 62   | 62   | 67   | 72   | 57         | 62   | 62   | 67   | 72   | 57         | 62   | 62   | 67   | 72   |
| 65  | T.C.              | 19.5                    | 30.3 | 25.6 | 25.2 | 19.8 | 20.4       | 31.2 | 26.6 | 26.2 | 20.0 | 21.4       | 32.2 | 27.6 | 27.1 | 20.3 |
|   | S.C.              | 18.0                    | 3.2  | 3.2  | 3.3  | 3.3  | 18.8       | 3.3  | 3.2  | 3.3  | 3.3  | 19.7       | 3.3  | 3.2  | 3.3  | 3.3  |
|   | K.W.              | 1.0                     | 1.0  | 1.0  | 1.0  | 1.0  | 1.0        | 1.0  | 1.0  | 1.0  | 1.0  | 1.1        | 1.1  | 1.1  | 1.0  | 1.0  |
| 75  | T.C.              | 18.6                    | 19.2 | 18.4 | 20.8 | 22.6 | 19.5       | 19.7 | 18.8 | 21.2 | 23.2 | 20.3       | 20.3 | 19.2 | 21.5 | 23.7 |
|   | S.C.              | 17.1                    | 16.7 | 13.7 | 14.1 | 11.1 | 17.9       | 17.7 | 14.5 | 14.8 | 11.7 | 18.6       | 18.6 | 15.2 | 15.5 | 12.4 |
|   | K.W.              | 1.2                     | 1.2  | 1.2  | 1.2  | 1.2  | 1.2        | 1.2  | 1.2  | 1.1  | 1.1  | 1.2        | 1.2  | 1.2  | 1.1  | 1.1  |
| 85  | T.C.              | 17.7                    | 18.1 | 17.4 | 19.6 | 21.3 | 18.5       | 18.5 | 17.9 | 19.9 | 21.6 | 19.3       | 19.0 | 18.4 | 20.2 | 22.0 |
|   | S.C.              | 16.2                    | 16.0 | 13.2 | 13.6 | 10.7 | 16.9       | 16.9 | 13.9 | 14.1 | 11.3 | 17.6       | 17.8 | 14.6 | 14.7 | 11.8 |
|   | K.W.              | 1.4                     | 1.3  | 1.3  | 1.3  | 1.3  | 1.3        | 1.3  | 1.3  | 1.3  | 1.3  | 1.3        | 1.3  | 1.3  | 1.2  | 1.2  |
| 95  | T.C.              | 16.9                    | 17.0 | 16.4 | 18.3 | 20.0 | 17.6       | 17.4 | 16.7 | 18.6 | 20.3 | 18.4       | 17.9 | 17.1 | 18.9 | 20.5 |
|   | S.C.              | 15.3                    | 15.3 | 12.6 | 13.0 | 10.3 | 16.0       | 16.1 | 13.3 | 13.6 | 10.8 | 16.7       | 17.0 | 14.0 | 14.2 | 11.3 |
|   | K.W.              | 1.5                     | 1.5  | 1.5  | 1.5  | 1.5  | 1.5        | 1.5  | 1.5  | 1.5  | 1.5  | 1.5        | 1.5  | 1.5  | 1.5  | 1.5  |
| 105   | T.C.              | 16.1                    | 16.0 | 15.2 | 17.1 | 18.6 | 16.8       | 16.4 | 15.5 | 17.4 | 18.8 | 17.5       | 16.8 | 15.9 | 17.6 | 19.0 |
|   | S.C.              | 14.6                    | 14.8 | 12.1 | 12.5 | 9.9  | 15.2       | 15.5 | 12.7 | 13.1 | 10.3 | 15.8       | 16.2 | 13.4 | 13.7 | 10.7 |
|   | K.W.              | 1.8                     | 1.7  | 1.8  | 1.7  | 1.7  | 1.7        | 1.7  | 1.7  | 1.7  | 1.7  | 1.7        | 1.7  | 1.7  | 1.7  | 1.7  |
| 115   | T.C.              | 15.4                    | 15.0 | 14.0 | 15.9 | 17.2 | 16.0       | 15.3 | 14.3 | 16.1 | 17.4 | 16.7       | 15.7 | 14.7 | 16.4 | 17.6 |
|   | S.C.              | 13.8                    | 14.3 | 11.6 | 12.1 | 9.4  | 14.4       | 14.8 | 12.2 | 12.6 | 9.8  | 14.9       | 15.4 | 12.8 | 13.2 | 10.2 |
|   | K.W.              | 2.0                     | 2.0  | 2.0  | 2.0  | 2.0  | 2.0        | 2.0  | 2.0  | 2.0  | 1.9  | 2.0        | 2.0  | 2.0  | 2.0  | 1.9  |
| 125   | T.C.              | 14.7                    | 13.9 | 12.8 | 14.7 | 15.8 | 15.3       | 14.3 | 13.1 | 14.9 | 16.0 | 15.8       | 14.6 | 13.4 | 15.1 | 16.2 |
|   | S.C.              | 13.1                    | 13.7 | 11.0 | 11.6 | 9.0  | 13.6       | 14.2 | 11.6 | 12.2 | 9.4  | 14.1       | 14.6 | 12.2 | 12.7 | 9.7  |
|   | K.W.              | 2.2                     | 2.2  | 2.2  | 2.2  | 2.2  | 2.2        | 2.2  | 2.2  | 2.2  | 2.2  | 2.2        | 2.2  | 2.2  | 2.2  | 2.2  |

NOTE: ALL CAPACITIES ARE NET (KBTUH) WITH INDOOR FAN HEAT ALREADY DEDUCTED AT 1250 BTUH/1000 CFM.

### Multipliers for determining the performance with other indoor sections.

NOTE: For dry bulb temperatures different than those listed (between 73-87 F), sensible capacity increases by 1060 BTUH per 1000 CFM per degree above the listed temperature and decreases by 1060 BTUH per 1000 CFM per degree below the listed temperature.

NOTE: KW RATING IS FOR OUTDOOR AND INDOOR UNITS.

### LOW CFM

| <b>Air Handler</b> | <b>Coil</b> | <b>T.C.</b> | <b>S.C.</b> | <b>KW</b> |
|--------------------|-------------|-------------|-------------|-----------|
| AV24               | -           | 1.01        | 1.00        | 1.00      |
| AV36               | -           | 1.01        | 1.00        | 1.00      |
| MV12B              | FC/MC30B    | 0.97        | 1.06        | 1.00      |
| MV12B              | FC/MC35B    | 0.97        | 1.06        | 1.00      |
| MV12B              | FC/MC36B    | 1.00        | 1.00        | 1.00      |
| MV12B              | FC/MC42B    | 0.97        | 1.06        | 1.00      |
| MV16C              | FC/MC35C    | 1.00        | 1.00        | 1.00      |
| MV16C              | FC/MC42C    | 1.00        | 1.00        | 1.00      |

| <b>Variable Speed Furnace</b> | <b>Coil</b> | <b>T.C.</b> | <b>S.C.</b> | <b>KW</b> |
|-------------------------------|-------------|-------------|-------------|-----------|
| PV8*A12                       | FC/MC/PC30A | 0.99        | 1.06        | 1.01      |
| PV9*A12                       | FC/MC/PC30A | 0.99        | 1.06        | 1.01      |
| P(C,V)9*B12                   | FC/MC/PC30B | 0.99        | 1.06        | 1.01      |
| PV9*A12                       | FC/MC/PC32A | 0.99        | 1.06        | 1.01      |
| P(C,V)9*B12                   | FC/MC/PC35B | 0.99        | 1.06        | 1.01      |
| PV8*A12                       | FC/MC/PC36A | 0.94        | 0.85        | 0.92      |
| PV9*A12                       | FC/MC/PC36A | 0.99        | 1.01        | 0.99      |
| P(C,V)9*B12                   | FC/MC/PC36B | 0.99        | 1.01        | 0.99      |
| P(C,V)9*B12                   | FC/MC/PC42B | 0.96        | 0.99        | 0.98      |
| P(C,V)9*B12                   | HC30        | 0.96        | 0.99        | 0.98      |
| P(C,V)9*B12                   | HC36        | 0.99        | 1.01        | 0.99      |
| P(C,V)9*B12                   | HD36        | 0.99        | 1.01        | 0.99      |
| PV8*A12                       | UC30A       | 0.96        | 0.99        | 0.98      |
| P(C,V)9*B12                   | UC30B       | 0.96        | 0.99        | 0.98      |
| PV8*A12                       | UC36A       | 0.99        | 1.01        | 0.99      |
| P(C,V)9*B12                   | UC36B       | 0.99        | 1.01        | 0.99      |
| P(C,V)9*B12                   | UC42B       | 0.99        | 1.01        | 0.99      |

| <b>COOLING PERFORMANCE DATA - HIGH CFM 2-STAGE OPERATION</b> |            |                         |      |      |      |      |      |      |      |      |      |      |      |      |      |      |
|--|------------|-------------------------|------|------|------|------|------|------|------|------|------|------|------|------|------|------|
| <b>OUTDOOR UNIT MODEL NO.</b>                                |            | <b>YZE02411</b>         |      |      |      |      |      |      |      |      |      |      |      |      |      |      |
| <b>INDOOR COIL MODEL NO.</b>                                 |            | <b>FC/MC36B + MV12B</b> |      |      |      |      |      |      |      |      |      |      |      |      |      |      |
| <b>CONDENSER ENTERING AIR TEMPERATURE</b>                    | ID CFM     | 700                     |      |      |      |      | 800  |      |      |      |      | 900  |      |      |      |      |
|  | ID DB (°F) | 80                      | 80   | 75   | 80   | 80   | 80   | 80   | 75   | 80   | 80   | 80   | 80   | 75   | 80   | 80   |
|  | ID WB (°F) | 57                      | 62   | 62   | 67   | 72   | 57   | 62   | 62   | 67   | 57   | 62   | 62   | 67   | 72   | 57   |
| 65   | T.C.       | 23.9                    | 24.9 | 23.7 | 27.3 | 29.1 | 25.2 | 25.8 | 24.6 | 28.0 | 30.0 | 26.5 | 26.7 | 25.4 | 28.8 | 30.9 |
|  | S.C.       | 22.6                    | 21.7 | 18.0 | 18.9 | 14.6 | 23.8 | 23.1 | 19.5 | 20.3 | 15.7 | 24.9 | 24.5 | 21.0 | 21.6 | 16.8 |
|  | K.W.       | 1.4                     | 1.4  | 1.4  | 1.4  | 1.4  | 1.4  | 1.4  | 1.4  | 1.4  | 1.4  | 1.4  | 1.4  | 1.4  | 1.4  | 1.5  |
| 75   | T.C.       | 23.4                    | 24.1 | 23.0 | 26.1 | 28.0 | 24.6 | 24.9 | 23.7 | 26.9 | 28.8 | 25.9 | 25.8 | 24.4 | 27.6 | 29.6 |
|  | S.C.       | 22.1                    | 21.5 | 17.7 | 18.3 | 14.3 | 23.2 | 22.9 | 19.1 | 19.7 | 15.4 | 24.3 | 24.3 | 20.5 | 21.0 | 16.5 |
|  | K.W.       | 1.6                     | 1.6  | 1.6  | 1.6  | 1.6  | 1.6  | 1.6  | 1.6  | 1.6  | 1.6  | 1.6  | 1.6  | 1.6  | 1.6  | 1.6  |
| 85   | T.C.       | 22.9                    | 23.2 | 22.2 | 25.0 | 26.9 | 24.1 | 24.1 | 22.8 | 25.7 | 27.6 | 25.2 | 24.9 | 23.5 | 26.4 | 28.3 |
|  | S.C.       | 21.6                    | 21.2 | 17.4 | 17.8 | 14.0 | 22.7 | 22.6 | 18.8 | 19.2 | 15.0 | 23.6 | 24.1 | 20.1 | 20.5 | 16.1 |
|  | K.W.       | 1.7                     | 1.8  | 1.7  | 1.8  | 1.8  | 1.7  | 1.8  | 1.7  | 1.8  | 1.8  | 1.8  | 1.8  | 1.7  | 1.8  | 1.8  |
| 95   | T.C.       | 22.4                    | 22.4 | 21.5 | 23.9 | 25.8 | 23.5 | 23.2 | 22.0 | 24.6 | 26.4 | 24.6 | 24.0 | 22.5 | 25.3 | 27.1 |
|  | S.C.       | 21.2                    | 20.9 | 17.1 | 17.3 | 13.6 | 22.1 | 22.4 | 18.4 | 18.6 | 14.7 | 23.0 | 23.8 | 19.7 | 19.9 | 15.7 |
|  | K.W.       | 1.9                     | 1.9  | 1.9  | 2.0  | 2.0  | 1.9  | 2.0  | 1.9  | 2.0  | 2.0  | 2.0  | 2.0  | 1.9  | 2.0  | 2.0  |
| 105  | T.C.       | 21.3                    | 21.1 | 20.0 | 22.5 | 24.1 | 22.4 | 22.0 | 20.5 | 23.2 | 24.7 | 23.4 | 22.8 | 21.0 | 23.8 | 25.3 |
|  | S.C.       | 20.2                    | 20.0 | 16.4 | 16.8 | 13.2 | 21.0 | 21.2 | 17.6 | 18.1 | 14.1 | 21.8 | 22.3 | 18.9 | 19.4 | 15.1 |
|  | K.W.       | 2.2                     | 2.2  | 2.2  | 2.3  | 2.3  | 2.2  | 2.2  | 2.2  | 2.3  | 2.3  | 2.2  | 2.3  | 2.2  | 2.3  | 2.3  |
| 115  | T.C.       | 20.3                    | 19.9 | 18.7 | 21.2 | 22.5 | 21.3 | 20.8 | 19.2 | 21.7 | 23.0 | 22.2 | 21.6 | 19.6 | 22.3 | 23.5 |
|  | S.C.       | 19.2                    | 19.1 | 15.6 | 16.3 | 12.7 | 19.9 | 20.0 | 16.9 | 17.6 | 13.6 | 20.6 | 20.9 | 18.1 | 18.9 | 14.5 |
|  | K.W.       | 2.5                     | 2.5  | 2.5  | 2.5  | 2.6  | 2.5  | 2.5  | 2.5  | 2.5  | 2.6  | 2.5  | 2.5  | 2.5  | 2.5  | 2.6  |
| 125  | T.C.       | 19.3                    | 18.8 | 17.3 | 19.8 | 20.9 | 20.2 | 19.6 | 17.8 | 20.3 | 21.3 | 21.0 | 20.4 | 18.2 | 20.8 | 21.7 |
|  | S.C.       | 18.2                    | 18.2 | 14.9 | 15.8 | 12.3 | 18.8 | 18.9 | 16.1 | 17.1 | 13.1 | 19.4 | 19.4 | 17.3 | 18.4 | 14.0 |
|  | K.W.       | 2.8                     | 2.8  | 2.8  | 2.8  | 2.8  | 2.8  | 2.8  | 2.8  | 2.8  | 2.8  | 2.8  | 2.8  | 2.8  | 2.8  | 2.8  |

NOTE: ALL CAPACITIES ARE NET (KBTUH) WITH INDOOR FAN HEAT ALREADY DEDUCTED AT 1250 BTUH/1000 CFM.

### Multipliers for determining the performance with other indoor sections.

NOTE: For dry bulb temperatures different than those listed (between 73-87 F), sensible capacity increases by 1060 BTUH per 1000 CFM per degree above the listed temperature and decreases by 1060 BTUH per 1000 CFM per degree below the listed temperature.

NOTE: KW RATING IS FOR OUTDOOR AND INDOOR UNITS.

### HIGH CFM

| Air Handler | Coil     | T.C. | S.C. | KW   |
|-------------|----------|------|------|------|
| AV24        | -        | 1.01 | 1.00 | 1.00 |
| AV36        | -        | 1.01 | 1.00 | 1.00 |
| MV12B       | FC/MC30B | 0.96 | 1.05 | 0.99 |
| MV12B       | FC/MC35B | 0.96 | 1.05 | 0.99 |
| MV12B       | FC/MC36B | 1.00 | 1.00 | 1.00 |
| MV12B       | FC/MC42B | 0.96 | 1.05 | 0.99 |
| MV16C       | FC/MC35C | 1.00 | 1.00 | 1.00 |
| MV16C       | FC/MC42C | 1.00 | 1.00 | 1.00 |

| Variable Speed Furnace | Coil        | T.C. | S.C. | KW   |
|------------------------|-------------|------|------|------|
| PV8*A12                | FC/MC/PC30A | 1.00 | 1.02 | 1.00 |
| PV9*A12                | FC/MC/PC30A | 1.00 | 1.02 | 1.00 |
| P(C,V)9*B12            | FC/MC/PC30B | 1.00 | 1.02 | 1.00 |
| PV9*A12                | FC/MC/PC32A | 1.00 | 1.02 | 1.00 |
| P(C,V)9*B12            | FC/MC/PC35B | 1.00 | 1.02 | 1.00 |
| PV8*A12                | FC/MC/PC36A | 1.01 | 1.02 | 0.99 |
| PV9*A12                | FC/MC/PC36A | 1.01 | 1.03 | 0.99 |
| P(C,V)9*B12            | FC/MC/PC36B | 1.01 | 1.03 | 0.99 |
| P(C,V)9*B12            | FC/MC/PC42B | 1.00 | 1.03 | 0.97 |
| P(C,V)9*B12            | HC30        | 1.00 | 1.03 | 0.97 |
| P(C,V)9*B12            | HC36        | 1.01 | 1.03 | 0.99 |
| P(C,V)9*B12            | HD36        | 1.01 | 1.03 | 0.99 |
| PV8*A12                | UC30A       | 1.00 | 1.03 | 0.97 |
| P(C,V)9*B12            | UC30B       | 1.00 | 1.03 | 0.97 |
| PV8*A12                | UC36A       | 1.01 | 1.03 | 0.99 |
| P(C,V)9*B12            | UC36B       | 1.01 | 1.03 | 0.99 |
| P(C,V)9*B12            | UC42B       | 1.01 | 1.03 | 0.99 |

| <b>COOLING PERFORMANCE DATA - LOW CFM 1-STAGE OPERATION</b> |                   |                         |      |      |      |      |            |      |      |      |      |            |      |      |      |      |
|---|-------------------|-------------------------|------|------|------|------|------------|------|------|------|------|------------|------|------|------|------|
| <b>OUTDOOR UNIT MODEL NO.</b>                               |                   | <b>YZE03611</b>         |      |      |      |      |            |      |      |      |      |            |      |      |      |      |
| <b>INDOOR COIL MODEL NO.</b>                                |                   | <b>FC/MC48C + MV16C</b> |      |      |      |      |            |      |      |      |      |            |      |      |      |      |
| <b>CONDENSER ENTERING AIR TEMPERATURE</b>                   | <b>ID CFM</b>     | <b>750</b>              |      |      |      |      | <b>800</b> |      |      |      |      | <b>850</b> |      |      |      |      |
|   | <b>ID DB (°F)</b> | 80                      | 80   | 75   | 80   | 80   | 80         | 80   | 75   | 80   | 80   | 80         | 80   | 75   | 80   | 80   |
|   | <b>ID WB (°F)</b> | 57                      | 62   | 62   | 67   | 72   | 57         | 62   | 62   | 67   | 72   | 57         | 62   | 62   | 67   | 72   |
| 65  | T.C.              | 24.3                    | 26.1 | 25.5 | 28.1 | 31.9 | 24.8       | 26.4 | 25.9 | 28.5 | 32.2 | 25.3       | 26.6 | 26.3 | 28.8 | 32.5 |
|   | S.C.              | 23.9                    | 22.4 | 18.5 | 19.1 | 15.6 | 24.4       | 22.8 | 19.1 | 19.5 | 16.2 | 24.9       | 23.2 | 19.7 | 19.9 | 16.8 |
|   | K.W.              | 1.3                     | 1.3  | 1.3  | 1.3  | 1.2  | 1.3        | 1.3  | 1.3  | 1.2  | 1.2  | 1.3        | 1.3  | 1.3  | 1.2  | 1.2  |
| 75  | T.C.              | 23.2                    | 24.9 | 24.5 | 27.0 | 30.6 | 23.7       | 25.2 | 24.8 | 27.3 | 30.9 | 24.2       | 25.4 | 25.2 | 27.6 | 31.1 |
|   | S.C.              | 22.8                    | 21.6 | 18.1 | 18.5 | 15.3 | 23.3       | 22.1 | 18.7 | 19.0 | 15.8 | 23.8       | 22.6 | 19.2 | 19.5 | 16.3 |
|   | K.W.              | 1.5                     | 1.5  | 1.5  | 1.5  | 1.5  | 1.5        | 1.5  | 1.5  | 1.5  | 1.4  | 1.5        | 1.5  | 1.5  | 1.5  | 1.4  |
| 85  | T.C.              | 22.1                    | 23.6 | 23.4 | 25.9 | 29.4 | 22.6       | 23.9 | 23.7 | 26.2 | 29.5 | 23.1       | 24.2 | 24.1 | 26.4 | 29.7 |
|   | S.C.              | 21.7                    | 20.8 | 17.7 | 17.9 | 15.0 | 22.2       | 21.4 | 18.2 | 18.5 | 15.4 | 22.7       | 22.0 | 18.8 | 19.1 | 15.8 |
|   | K.W.              | 1.8                     | 1.7  | 1.7  | 1.7  | 1.7  | 1.7        | 1.7  | 1.7  | 1.7  | 1.7  | 1.7        | 1.7  | 1.7  | 1.7  | 1.7  |
| 95  | T.C.              | 21.0                    | 22.3 | 22.4 | 24.8 | 28.1 | 21.5       | 22.7 | 22.6 | 25.0 | 28.2 | 21.9       | 23.0 | 22.9 | 25.2 | 28.3 |
|   | S.C.              | 20.7                    | 20.0 | 17.3 | 17.3 | 14.6 | 21.1       | 20.7 | 17.8 | 18.0 | 15.0 | 21.6       | 21.4 | 18.3 | 18.7 | 15.4 |
|   | K.W.              | 2.0                     | 2.0  | 2.0  | 2.0  | 1.9  | 2.0        | 2.0  | 2.0  | 1.9  | 1.9  | 2.0        | 2.0  | 2.0  | 1.9  | 1.9  |
| 105   | T.C.              | 19.8                    | 20.9 | 20.9 | 23.1 | 26.1 | 20.3       | 21.2 | 21.1 | 23.3 | 26.2 | 20.7       | 21.6 | 21.4 | 23.5 | 26.4 |
|   | S.C.              | 19.5                    | 19.1 | 16.3 | 16.6 | 13.9 | 20.0       | 19.8 | 16.9 | 17.3 | 14.2 | 20.4       | 20.4 | 17.4 | 18.0 | 14.5 |
|   | K.W.              | 2.3                     | 2.3  | 2.3  | 2.3  | 2.2  | 2.3        | 2.3  | 2.3  | 2.3  | 2.2  | 2.3        | 2.3  | 2.3  | 2.3  | 2.2  |
| 115   | T.C.              | 18.7                    | 19.5 | 19.4 | 21.5 | 24.2 | 19.1       | 19.8 | 19.6 | 21.7 | 24.3 | 19.5       | 20.2 | 19.9 | 21.9 | 24.5 |
|   | S.C.              | 18.4                    | 18.3 | 15.4 | 16.0 | 13.3 | 18.8       | 18.9 | 16.0 | 16.6 | 13.5 | 19.2       | 19.4 | 16.5 | 17.3 | 13.7 |
|   | K.W.              | 2.7                     | 2.6  | 2.6  | 2.6  | 2.6  | 2.7        | 2.6  | 2.6  | 2.6  | 2.6  | 2.6        | 2.6  | 2.6  | 2.6  | 2.5  |
| 125   | T.C.              | 17.5                    | 18.0 | 18.0 | 19.9 | 22.3 | 17.9       | 18.4 | 18.2 | 20.1 | 22.5 | 18.3       | 18.7 | 18.3 | 20.3 | 22.6 |
|   | S.C.              | 17.3                    | 17.4 | 14.4 | 15.4 | 12.6 | 17.7       | 18.0 | 15.0 | 16.0 | 12.8 | 18.1       | 18.5 | 15.7 | 16.6 | 12.9 |
|   | K.W.              | 3.0                     | 3.0  | 3.0  | 2.9  | 2.9  | 3.0        | 3.0  | 3.0  | 2.9  | 2.9  | 3.0        | 2.9  | 2.9  | 2.9  | 2.9  |

NOTE: ALL CAPACITIES ARE NET (KBTUH) WITH INDOOR FAN HEAT ALREADY DEDUCTED AT 1250 BTUH/1000 CFM.

**Multipliers for determining the performance with other indoor sections.**

NOTE: For dry bulb temperatures different than those listed (between 73-87 F), sensible capacity increases by 1060 BTUH per 1000 CFM per degree above the listed temperature and decreases by 1060 BTUH per 1000 CFM per degree below the listed temperature.

NOTE: KW RATING IS FOR OUTDOOR AND INDOOR UNITS.

**LOW CFM**

| <b>Air Handler</b> | <b>Coil</b> | <b>T.C.</b> | <b>S.C.</b> | <b>KW</b> |
|--------------------|-------------|-------------|-------------|-----------|
| AV36               | -           | 1.00        | 1.00        | 1.00      |
| AV48               | -           | 1.00        | 1.00        | 1.00      |
| MV12B              | FC/MC35B    | 0.98        | 0.98        | 1.00      |
| MV12B              | FC/MC42B    | 0.98        | 0.98        | 1.00      |
| MV16C              | FC/MC48C    | 1.00        | 1.00        | 1.00      |
| MV12D              | FC/MC48D    | 0.99        | 1.00        | 1.00      |

| <b>Variable Speed Furnace</b> | <b>Coil</b> | <b>T.C.</b> | <b>S.C.</b> | <b>KW</b> |
|-------------------------------|-------------|-------------|-------------|-----------|
| PV8*C16                       | FC/MC/PC42C | 0.98        | 1.05        | 1.02      |
| PV8*C20                       | FC/MC/PC42C | 0.98        | 1.05        | 1.02      |
| P(C,V)9*C20                   | FC/MC/PC48C | 0.97        | 0.93        | 0.98      |
| P(C,V)9*C16                   | FC/MC/PC48C | 0.97        | 0.93        | 0.98      |
| PV8*C16                       | FC/MC/PC48C | 1.00        | 1.08        | 1.00      |
| PV8*C20                       | FC/MC/PC48C | 1.01        | 1.09        | 1.00      |
| P(C,V)9*D20                   | FC/MC/PC48D | 1.00        | 1.07        | 1.00      |
| PV8*C16                       | HC42        | 0.97        | 0.93        | 0.98      |
| PV8*C20                       | HC42        | 0.97        | 0.93        | 0.98      |
| PV8*B16                       | UC42B       | 0.97        | 0.93        | 0.98      |
| P(C,V)9*B12                   | UC42B       | 0.97        | 0.93        | 0.98      |
| PV8*C20                       | UC42C       | 0.97        | 0.93        | 0.98      |
| PV8*C16                       | UC42C       | 0.97        | 0.93        | 0.98      |
| P(C,V)9*C16                   | UC42C       | 0.97        | 0.93        | 0.98      |
| P(C,V)9*C20                   | UC42C       | 0.97        | 0.93        | 0.98      |
| P(C,V)9*C20                   | UC48C       | 0.97        | 0.93        | 0.98      |
| PV8*C20                       | UC48C       | 0.97        | 0.93        | 0.98      |
| PV8*C16                       | UC48C       | 0.97        | 0.93        | 0.98      |
| P(C,V)9*C16                   | UC48C       | 0.97        | 0.93        | 0.98      |
| P(C,V)9*D20                   | UC48D       | 0.97        | 0.93        | 0.98      |

| <b>Variable Speed Furnace</b> | <b>Coil</b> | <b>T.C.</b> | <b>S.C.</b> | <b>KW</b> |
|-------------------------------|-------------|-------------|-------------|-----------|
| P(C,V)9*B12                   | FC/MC/PC35B | 0.92        | 0.89        | 0.98      |
| PV8*B16                       | FC/MC/PC35B | 0.92        | 0.89        | 0.98      |
| P(C,V)9*C16                   | FC/MC/PC35C | 0.92        | 0.89        | 0.98      |
| PV8*C16                       | FC/MC/PC35C | 0.92        | 0.89        | 0.98      |
| PV8*C20                       | FC/MC/PC35C | 0.92        | 0.89        | 0.98      |
| P(C,V)9*C20                   | FC/MC/PC35C | 0.92        | 0.89        | 0.98      |
| PV8*B16                       | FC/MC/PC42B | 0.92        | 0.89        | 0.98      |
| P(C,V)9*B12                   | FC/MC/PC42B | 0.98        | 1.05        | 1.02      |
| P(C,V)9*C20                   | FC/MC/PC42C | 0.92        | 0.89        | 0.98      |
| P(C,V)9*C16                   | FC/MC/PC42C | 0.92        | 0.89        | 0.98      |

| <b>COOLING PERFORMANCE DATA - HIGH CFM 2-STAGE OPERATION</b> |                   |                         |      |      |      |      |      |      |      |      |      |      |      |      |      |      |
|--|-------------------|-------------------------|------|------|------|------|------|------|------|------|------|------|------|------|------|------|
| <b>OUTDOOR UNIT MODEL NO.</b>                                |                   | <b>YZE03611</b>         |      |      |      |      |      |      |      |      |      |      |      |      |      |      |
| <b>INDOOR COIL MODEL NO.</b>                                 |                   | <b>FC/MC48C + MV16C</b> |      |      |      |      |      |      |      |      |      |      |      |      |      |      |
| <b>CONDENSER ENTERING AIR TEMPERATURE</b>                    | <b>ID CFM</b>     | 1100                    |      |      |      |      | 1200 |      |      |      |      | 1300 |      |      |      |      |
|  | <b>ID DB (°F)</b> | 80                      | 80   | 75   | 80   | 80   | 80   | 80   | 75   | 80   | 80   | 80   | 80   | 75   | 80   | 80   |
|  | <b>ID WB (°F)</b> | 57                      | 62   | 62   | 67   | 72   | 57   | 62   | 62   | 67   | 57   | 62   | 62   | 67   | 72   | 57   |
| 65   | T.C.              | 31.6                    | 36.2 | 37.2 | 37.3 | 38.5 | 33.1 | 36.3 | 37.6 | 37.4 | 38.3 | 34.7 | 36.5 | 37.9 | 37.6 | 38.1 |
|  | S.C.              | 31.2                    | 30.3 | 26.6 | 24.5 | 19.1 | 32.9 | 31.3 | 27.6 | 24.9 | 19.3 | 34.5 | 32.3 | 28.5 | 25.4 | 19.5 |
|  | K.W.              | 1.9                     | 2.0  | 2.1  | 2.0  | 2.1  | 2.0  | 2.0  | 2.1  | 2.0  | 2.1  | 2.0  | 2.0  | 2.1  | 2.0  | 2.1  |
| 75   | T.C.              | 30.9                    | 34.6 | 35.3 | 36.5 | 38.4 | 32.4 | 34.9 | 35.7 | 36.8 | 38.3 | 33.9 | 35.2 | 36.0 | 37.0 | 38.1 |
|  | S.C.              | 30.7                    | 29.7 | 25.8 | 24.4 | 19.4 | 32.1 | 30.8 | 26.8 | 25.1 | 19.6 | 33.5 | 31.9 | 27.7 | 25.8 | 19.8 |
|  | K.W.              | 2.2                     | 2.3  | 2.3  | 2.3  | 2.4  | 2.2  | 2.3  | 2.3  | 2.3  | 2.4  | 2.3  | 2.3  | 2.4  | 2.3  | 2.4  |
| 85   | T.C.              | 30.3                    | 33.1 | 33.4 | 35.7 | 38.3 | 31.7 | 33.5 | 33.8 | 36.1 | 38.2 | 33.0 | 34.0 | 34.1 | 36.4 | 38.2 |
|  | S.C.              | 30.1                    | 29.1 | 25.0 | 24.4 | 19.7 | 31.3 | 30.4 | 26.0 | 25.2 | 19.9 | 32.4 | 31.6 | 26.9 | 26.1 | 20.2 |
|  | K.W.              | 2.5                     | 2.5  | 2.5  | 2.6  | 2.6  | 2.5  | 2.6  | 2.6  | 2.6  | 2.7  | 2.6  | 2.6  | 2.6  | 2.6  | 2.7  |
| 95   | T.C.              | 29.7                    | 31.6 | 31.5 | 34.9 | 38.1 | 30.9 | 32.1 | 31.9 | 35.4 | 38.2 | 32.2 | 32.7 | 32.2 | 35.9 | 38.3 |
|  | S.C.              | 29.5                    | 28.5 | 24.2 | 24.4 | 20.0 | 30.4 | 29.9 | 25.2 | 25.4 | 20.2 | 31.4 | 31.2 | 26.1 | 26.4 | 20.5 |
|  | K.W.              | 2.8                     | 2.8  | 2.8  | 2.8  | 2.9  | 2.8  | 2.8  | 2.8  | 2.9  | 2.9  | 2.8  | 2.9  | 2.8  | 2.9  | 3.0  |
| 105  | T.C.              | 28.2                    | 29.7 | 29.6 | 32.5 | 35.8 | 29.3 | 30.3 | 29.9 | 33.0 | 36.0 | 30.4 | 30.9 | 30.2 | 33.5 | 36.2 |
|  | S.C.              | 28.0                    | 27.2 | 23.2 | 23.3 | 19.0 | 28.8 | 28.5 | 23.9 | 24.3 | 19.4 | 29.7 | 29.7 | 24.6 | 25.3 | 19.7 |
|  | K.W.              | 3.2                     | 3.2  | 3.2  | 3.3  | 3.3  | 3.2  | 3.3  | 3.2  | 3.3  | 3.4  | 3.3  | 3.3  | 3.2  | 3.3  | 3.4  |
| 115  | T.C.              | 26.7                    | 27.9 | 27.7 | 30.2 | 33.5 | 27.7 | 28.5 | 28.0 | 30.7 | 33.8 | 28.6 | 29.1 | 28.3 | 31.2 | 34.2 |
|  | S.C.              | 26.6                    | 26.0 | 22.3 | 22.3 | 18.0 | 27.3 | 27.1 | 22.7 | 23.3 | 18.5 | 28.0 | 28.1 | 23.1 | 24.3 | 19.0 |
|  | K.W.              | 3.6                     | 3.7  | 3.6  | 3.7  | 3.8  | 3.7  | 3.7  | 3.6  | 3.7  | 3.8  | 3.7  | 3.7  | 3.6  | 3.8  | 3.8  |
| 125  | T.C.              | 25.3                    | 26.0 | 25.9 | 27.9 | 31.2 | 26.0 | 26.7 | 26.2 | 28.4 | 31.7 | 26.8 | 27.3 | 26.4 | 29.0 | 32.2 |
|  | S.C.              | 25.1                    | 24.7 | 21.3 | 21.3 | 17.0 | 25.7 | 25.7 | 21.5 | 22.3 | 17.6 | 26.3 | 26.6 | 21.6 | 23.2 | 18.2 |
|  | K.W.              | 4.1                     | 4.1  | 4.1  | 4.2  | 4.2  | 4.1  | 4.1  | 4.1  | 4.2  | 4.2  | 4.1  | 4.1  | 4.0  | 4.2  | 4.2  |

NOTE: ALL CAPACITIES ARE NET (KBTUH) WITH INDOOR FAN HEAT ALREADY DEDUCTED AT 1250 BTUH/1000 CFM.

### Multipliers for determining the performance with other indoor sections.

NOTE: For dry bulb temperatures different than those listed (between 73-87 F), sensible capacity increases by 1060 BTUH per 1000 CFM per degree above the listed temperature and decreases by 1060 BTUH per 1000 CFM per degree below the listed temperature.

NOTE: KW RATING IS FOR OUTDOOR AND INDOOR UNITS.

### HIGH CFM

| <b>Air Handler</b> | <b>Coil</b> | <b>T.C.</b> | <b>S.C.</b> | <b>KW</b> |
|--------------------|-------------|-------------|-------------|-----------|
| AV36               | -           | 1.00        | 1.00        | 1.00      |
| AV48               | -           | 1.00        | 1.00        | 1.00      |
| MV12B              | FC/MC35B    | 0.99        | 0.93        | 1.01      |
| MV12B              | FC/MC42B    | 0.99        | 0.93        | 1.01      |
| MV16C              | FC/MC48C    | 1.00        | 1.00        | 1.00      |
| MV12D              | FC/MC48D    | 1.00        | 1.00        | 1.00      |

| <b>Variable Speed Furnace</b> | <b>Coil</b> | <b>T.C.</b> | <b>S.C.</b> | <b>KW</b> |
|-------------------------------|-------------|-------------|-------------|-----------|
| P(C,V)9*B12                   | FC/MC/PC35B | 1.01        | 0.94        | 1.03      |
| PV8*B16                       | FC/MC/PC35B | 1.01        | 0.94        | 1.03      |
| P(C,V)9*C16                   | FC/MC/PC35C | 1.01        | 0.94        | 1.03      |
| PV8*C16                       | FC/MC/PC35C | 1.01        | 0.94        | 1.03      |
| PV8*C20                       | FC/MC/PC35C | 1.01        | 0.94        | 1.03      |
| P(C,V)9*C20                   | FC/MC/PC35C | 1.01        | 0.94        | 1.03      |
| PV8*B16                       | FC/MC/PC42B | 1.01        | 0.94        | 1.03      |
| P(C,V)9*B12                   | FC/MC/PC42B | 1.09        | 0.91        | 1.12      |
| P(C,V)9*C20                   | FC/MC/PC42C | 1.01        | 0.94        | 1.03      |
| P(C,V)9*C16                   | FC/MC/PC42C | 1.01        | 0.94        | 1.03      |

| <b>Variable Speed Furnace</b> | <b>Coil</b> | <b>T.C.</b> | <b>S.C.</b> | <b>KW</b> |
|-------------------------------|-------------|-------------|-------------|-----------|
| PV8*C16                       | FC/MC/PC42C | 1.09        | 0.91        | 1.12      |
| PV8*C20                       | FC/MC/PC42C | 1.09        | 0.91        | 1.12      |
| P(C,V)9*C20                   | FC/MC/PC48C | 1.05        | 1.02        | 1.05      |
| P(C,V)9*C16                   | FC/MC/PC48C | 1.05        | 1.02        | 1.05      |
| PV8*C16                       | FC/MC/PC48C | 1.11        | 1.00        | 1.11      |
| PV8*C20                       | FC/MC/PC48C | 1.11        | 1.00        | 1.11      |
| P(C,V)9*D20                   | FC/MC/PC48D | 1.11        | 1.00        | 1.11      |
| PV8*C16                       | HC42        | 1.05        | 1.02        | 1.05      |
| PV8*C20                       | HC42        | 1.05        | 1.02        | 1.05      |
| PV8*B16                       | UC42B       | 1.05        | 1.02        | 1.05      |
| P(C,V)9*B12                   | UC42B       | 1.05        | 1.02        | 1.05      |
| PV8*C20                       | UC42C       | 1.05        | 1.02        | 1.05      |
| PV8*C16                       | UC42C       | 1.05        | 1.02        | 1.05      |
| P(C,V)9*C16                   | UC42C       | 1.05        | 1.02        | 1.05      |
| P(C,V)9*C20                   | UC42C       | 1.05        | 1.02        | 1.05      |
| P(C,V)9*C20                   | UC48C       | 1.05        | 1.02        | 1.05      |
| PV8*C20                       | UC48C       | 1.05        | 1.02        | 1.05      |
| PV8*C16                       | UC48C       | 1.05        | 1.02        | 1.05      |
| P(C,V)9*C16                   | UC48C       | 1.05        | 1.02        | 1.05      |
| P(C,V)9*D20                   | UC48D       | 1.05        | 1.02        | 1.05      |

| <b>COOLING PERFORMANCE DATA - LOW CFM 1-STAGE OPERATION</b> |                   |                         |      |      |      |      |             |      |      |      |      |             |      |      |      |      |
|---|-------------------|-------------------------|------|------|------|------|-------------|------|------|------|------|-------------|------|------|------|------|
| <b>OUTDOOR UNIT MODEL NO.</b>                               |                   | <b>YZE04811</b>         |      |      |      |      |             |      |      |      |      |             |      |      |      |      |
| <b>INDOOR COIL MODEL NO.</b>                                |                   | <b>FC/MC60D + MV20D</b> |      |      |      |      |             |      |      |      |      |             |      |      |      |      |
| <b>CONDENSER<br/>ENTERING AIR<br/>TEMPERATURE</b>           | <b>ID CFM</b>     | <b>950</b>              |      |      |      |      | <b>1000</b> |      |      |      |      | <b>1050</b> |      |      |      |      |
|   | <b>ID DB (°F)</b> | 80                      | 80   | 75   | 80   | 80   | 80          | 80   | 75   | 80   | 80   | 80          | 80   | 75   | 80   | 80   |
|   | <b>ID WB (°F)</b> | 57                      | 62   | 62   | 67   | 72   | 57          | 62   | 62   | 67   | 72   | 57          | 62   | 62   | 67   | 72   |
| 65  | T.C.              | 31.6                    | 34.3 | 34.2 | 39.4 | 44.4 | 31.9        | 34.5 | 34.8 | 40.0 | 44.9 | 32.3        | 34.8 | 35.4 | 40.6 | 45.4 |
|   | S.C.              | 31.6                    | 29.3 | 24.7 | 25.3 | 20.9 | 31.9        | 29.9 | 25.4 | 26.0 | 21.3 | 32.3        | 30.5 | 26.2 | 26.8 | 21.7 |
|   | K.W.              | 1.6                     | 1.6  | 1.6  | 1.6  | 1.6  | 1.6         | 1.6  | 1.6  | 1.6  | 1.6  | 1.6         | 1.6  | 1.6  | 1.6  | 1.6  |
| 75  | T.C.              | 30.4                    | 32.4 | 32.5 | 37.2 | 42.1 | 30.7        | 32.7 | 33.0 | 37.7 | 42.5 | 31.1        | 33.0 | 33.5 | 38.2 | 43.0 |
|   | S.C.              | 30.3                    | 28.2 | 23.9 | 24.5 | 20.0 | 30.7        | 28.8 | 24.6 | 25.2 | 20.4 | 31.1        | 29.4 | 25.3 | 25.9 | 20.9 |
|   | K.W.              | 2.0                     | 1.9  | 1.9  | 1.9  | 1.9  | 1.9         | 1.9  | 1.9  | 1.9  | 1.9  | 1.9         | 1.9  | 1.9  | 1.9  | 1.9  |
| 85  | T.C.              | 29.2                    | 30.6 | 30.8 | 35.1 | 39.7 | 29.5        | 30.8 | 31.2 | 35.5 | 40.1 | 29.9        | 31.1 | 31.5 | 35.9 | 40.5 |
|   | S.C.              | 29.1                    | 27.0 | 23.2 | 23.6 | 19.1 | 29.5        | 27.6 | 23.9 | 24.3 | 19.6 | 29.9        | 28.2 | 24.5 | 25.0 | 20.0 |
|   | K.W.              | 2.3                     | 2.3  | 2.2  | 2.2  | 2.2  | 2.3         | 2.3  | 2.2  | 2.2  | 2.2  | 2.3         | 2.2  | 2.2  | 2.2  | 2.2  |
| 95  | T.C.              | 28.0                    | 28.7 | 29.1 | 32.9 | 37.3 | 28.4        | 29.0 | 29.4 | 33.2 | 37.7 | 28.7        | 29.2 | 29.6 | 33.5 | 38.0 |
|   | S.C.              | 27.9                    | 25.9 | 22.5 | 22.8 | 18.3 | 28.3        | 26.5 | 23.1 | 23.5 | 18.7 | 28.7        | 27.1 | 23.6 | 24.2 | 19.2 |
|   | K.W.              | 2.6                     | 2.6  | 2.6  | 2.5  | 2.5  | 2.6         | 2.6  | 2.6  | 2.5  | 2.5  | 2.6         | 2.6  | 2.6  | 2.5  | 2.5  |
| 105   | T.C.              | 26.3                    | 26.7 | 27.0 | 30.6 | 34.8 | 26.8        | 27.2 | 27.2 | 30.8 | 35.1 | 27.2        | 27.6 | 27.5 | 31.1 | 35.4 |
|   | S.C.              | 26.2                    | 24.9 | 21.5 | 22.0 | 17.5 | 26.7        | 25.5 | 22.0 | 22.6 | 17.9 | 27.1        | 26.2 | 22.6 | 23.2 | 18.4 |
|   | K.W.              | 3.0                     | 3.0  | 3.0  | 3.0  | 3.0  | 3.0         | 3.0  | 3.0  | 3.0  | 3.0  | 3.0         | 3.0  | 3.0  | 3.0  | 3.0  |
| 115   | T.C.              | 24.7                    | 24.8 | 24.9 | 28.3 | 32.4 | 25.3        | 25.4 | 25.2 | 28.5 | 32.6 | 25.8        | 26.1 | 25.4 | 28.7 | 32.9 |
|   | S.C.              | 24.6                    | 23.9 | 20.5 | 21.1 | 16.8 | 25.1        | 24.6 | 21.1 | 21.7 | 17.2 | 25.6        | 25.4 | 21.6 | 22.3 | 17.5 |
|   | K.W.              | 3.4                     | 3.4  | 3.4  | 3.4  | 3.4  | 3.4         | 3.4  | 3.4  | 3.4  | 3.4  | 3.4         | 3.4  | 3.4  | 3.4  | 3.4  |
| 125   | T.C.              | 23.2                    | 22.8 | 22.8 | 26.1 | 30.0 | 23.7        | 23.7 | 23.1 | 26.2 | 30.1 | 24.3        | 24.5 | 23.4 | 26.3 | 30.3 |
|   | S.C.              | 23.0                    | 22.9 | 19.6 | 20.3 | 16.1 | 23.6        | 23.7 | 20.1 | 20.9 | 16.4 | 24.1        | 24.5 | 20.6 | 21.4 | 16.7 |
|   | K.W.              | 3.8                     | 3.8  | 3.8  | 3.8  | 3.8  | 3.8         | 3.8  | 3.8  | 3.8  | 3.8  | 3.8         | 3.8  | 3.8  | 3.8  | 3.8  |

NOTE: ALL CAPACITIES ARE NET (KBTUH) WITH INDOOR FAN HEAT ALREADY DEDUCTED AT 1250 BTUH/1000 CFM.

### Multipliers for determining the performance with other indoor sections.

NOTE: For dry bulb temperatures different than those listed (between 73-87 F), sensible capacity increases by 1060 BTUH per 1000 CFM per degree above the listed temperature and decreases by 1060 BTUH per 1000 CFM per degree below the listed temperature.

NOTE: KW RATING IS FOR OUTDOOR AND INDOOR UNITS.

### LOW CFM

| <b>Air Handler</b> | <b>Coil</b> | <b>T.C.</b> | <b>S.C.</b> | <b>KW</b> |
|--------------------|-------------|-------------|-------------|-----------|
| F*FV060            | -           | 1.00        | 1.00        | 1.00      |
| AV48               | -           | 1.00        | 1.00        | 1.00      |
| AV60               | -           | 1.00        | 1.00        | 1.00      |
| MV20D              | FC/MC60D    | 1.00        | 1.00        | 1.00      |
| MV20D              | FC/MC62D    | 1.01        | 1.01        | 0.99      |

| <b>Variable Speed Furnace</b> | <b>Coil</b> | <b>T.C.</b> | <b>S.C.</b> | <b>KW</b> |
|-------------------------------|-------------|-------------|-------------|-----------|
| P(C,V)9*D20                   | FC/MC/PC60D | 0.98        | 0.94        | 0.99      |
| P(C,V)9*D20                   | FC/MC62D    | 1.00        | 1.09        | 1.02      |
| PV8*C20                       | FC/PC60C    | 0.98        | 0.94        | 0.99      |
| P(C,V)9*C20                   | FC/PC60C    | 0.98        | 0.94        | 0.99      |
| P(C,V)9*D20                   | HC60        | 0.98        | 0.94        | 0.99      |
| PV8*C20                       | HC60        | 0.98        | 0.94        | 0.99      |
| P(C,V)9*D20                   | HD60        | 0.98        | 0.94        | 0.99      |
| P(C,V)9*D20                   | FC/MC62D    | 1.00        | 1.09        | 1.02      |
| P(C,V)9*C20                   | UC60C       | 0.98        | 0.94        | 0.99      |
| PV8*C20                       | UC60C       | 0.98        | 0.94        | 0.99      |
| P(C,V)9*D20                   | UC60D       | 0.98        | 0.94        | 0.99      |

| <b>COOLING PERFORMANCE DATA - HIGH CFM 2-STAGE OPERATION</b> |                   |                         |      |      |      |      |      |      |      |      |      |      |      |      |      |      |
|--|-------------------|-------------------------|------|------|------|------|------|------|------|------|------|------|------|------|------|------|
| <b>OUTDOOR UNIT MODEL NO.</b>                                |                   | <b>YZE04811</b>         |      |      |      |      |      |      |      |      |      |      |      |      |      |      |
| <b>INDOOR COIL MODEL NO.</b>                                 |                   | <b>FC/MC60D + MV20D</b> |      |      |      |      |      |      |      |      |      |      |      |      |      |      |
| <b>CONDENSER ENTERING AIR TEMPERATURE</b>                    | <b>ID CFM</b>     | 1500                    |      |      |      |      | 1600 |      |      |      |      | 1700 |      |      |      |      |
|  | <b>ID DB (°F)</b> | 80                      | 80   | 75   | 80   | 80   | 80   | 80   | 75   | 80   | 80   | 80   | 80   | 75   | 80   | 80   |
|  | <b>ID WB (°F)</b> | 57                      | 62   | 62   | 67   | 72   | 57   | 62   | 62   | 67   | 72   | 57   | 62   | 62   | 67   | 72   |
| 65   | T.C.              | 42.6                    | 46.0 | 47.1 | 52.2 | 59.2 | 43.3 | 46.5 | 47.6 | 52.8 | 59.5 | 44.0 | 46.9 | 48.0 | 53.4 | 59.7 |
|  | S.C.              | 43.5                    | 41.8 | 35.9 | 36.2 | 29.0 | 44.2 | 42.9 | 37.0 | 37.3 | 29.6 | 44.9 | 44.0 | 38.0 | 38.4 | 30.2 |
|  | K.W.              | 2.6                     | 2.6  | 2.6  | 2.7  | 2.8  | 2.6  | 2.7  | 2.7  | 2.8  | 2.9  | 2.7  | 2.7  | 2.7  | 2.8  | 2.9  |
| 75   | T.C.              | 41.4                    | 44.1 | 45.0 | 50.0 | 56.4 | 42.1 | 44.5 | 45.4 | 50.6 | 56.7 | 42.7 | 44.9 | 45.9 | 51.1 | 57.0 |
|  | S.C.              | 42.2                    | 40.7 | 35.0 | 35.3 | 28.0 | 42.9 | 41.7 | 36.1 | 36.3 | 28.7 | 43.6 | 42.7 | 37.1 | 37.4 | 29.3 |
|  | K.W.              | 2.9                     | 3.0  | 3.0  | 3.1  | 3.2  | 3.0  | 3.0  | 3.0  | 3.1  | 3.2  | 3.0  | 3.1  | 3.1  | 3.2  | 3.3  |
| 85   | T.C.              | 40.2                    | 42.2 | 42.9 | 47.8 | 53.6 | 40.8 | 42.6 | 43.3 | 48.3 | 53.9 | 41.5 | 43.0 | 43.7 | 48.7 | 54.3 |
|  | S.C.              | 41.0                    | 39.6 | 34.1 | 34.3 | 27.1 | 41.6 | 40.6 | 35.2 | 35.4 | 27.7 | 42.2 | 41.5 | 36.2 | 36.4 | 28.3 |
|  | K.W.              | 3.3                     | 3.3  | 3.3  | 3.4  | 3.5  | 3.3  | 3.3  | 3.4  | 3.4  | 3.5  | 3.4  | 3.4  | 3.4  | 3.5  | 3.6  |
| 95   | T.C.              | 39.0                    | 40.2 | 40.8 | 45.6 | 50.8 | 39.6 | 40.7 | 41.2 | 46.0 | 51.2 | 40.2 | 41.1 | 41.6 | 46.3 | 51.5 |
|  | S.C.              | 39.7                    | 38.4 | 33.3 | 33.3 | 26.1 | 40.3 | 39.4 | 34.3 | 34.4 | 26.8 | 40.8 | 40.3 | 35.3 | 35.5 | 27.4 |
|  | K.W.              | 3.6                     | 3.7  | 3.7  | 3.7  | 3.8  | 3.7  | 3.7  | 3.7  | 3.8  | 3.9  | 3.7  | 3.7  | 3.7  | 3.8  | 3.9  |
| 105  | T.C.              | 36.7                    | 37.5 | 37.7 | 42.4 | 47.2 | 37.2 | 37.9 | 38.1 | 42.7 | 47.6 | 37.7 | 38.2 | 38.4 | 43.0 | 48.0 |
|  | S.C.              | 37.3                    | 36.4 | 31.4 | 32.1 | 25.2 | 37.8 | 37.1 | 32.4 | 33.1 | 25.7 | 38.2 | 37.8 | 33.3 | 34.1 | 26.3 |
|  | K.W.              | 4.2                     | 4.2  | 4.1  | 4.2  | 4.3  | 4.2  | 4.2  | 4.2  | 4.3  | 4.4  | 4.2  | 4.2  | 4.2  | 4.3  | 4.4  |
| 115  | T.C.              | 34.5                    | 34.9 | 34.7 | 39.3 | 43.6 | 34.9 | 35.2 | 35.1 | 39.5 | 44.1 | 35.3 | 35.5 | 35.4 | 39.8 | 44.5 |
|  | S.C.              | 35.0                    | 34.3 | 29.6 | 30.9 | 24.2 | 35.4 | 34.8 | 30.5 | 31.8 | 24.7 | 35.7 | 35.3 | 31.3 | 32.7 | 25.2 |
|  | K.W.              | 4.6                     | 4.6  | 4.6  | 4.7  | 4.8  | 4.7  | 4.7  | 4.7  | 4.8  | 4.8  | 4.7  | 4.7  | 4.7  | 4.8  | 4.9  |
| 125  | T.C.              | 32.3                    | 32.3 | 31.8 | 36.2 | 40.1 | 32.6 | 32.5 | 32.0 | 36.4 | 40.6 | 32.8 | 32.7 | 32.3 | 36.5 | 41.0 |
|  | S.C.              | 32.7                    | 32.3 | 27.9 | 29.6 | 23.3 | 32.9 | 32.6 | 28.6 | 30.5 | 23.7 | 33.2 | 32.8 | 29.3 | 31.4 | 24.1 |
|  | K.W.              | 5.1                     | 5.1  | 5.1  | 5.2  | 5.3  | 5.2  | 5.2  | 5.1  | 5.2  | 5.3  | 5.2  | 5.2  | 5.2  | 5.3  | 5.4  |

NOTE: ALL CAPACITIES ARE NET (KBTUH) WITH INDOOR FAN HEAT ALREADY DEDUCTED AT 1250 BTUH/1000 CFM.

### Multipliers for determining the performance with other indoor sections.

NOTE: For dry bulb temperatures different than those listed (between 73-87 F), sensible capacity increases by 1060 BTUH per 1000 CFM per degree above the listed temperature and decreases by 1060 BTUH per 1000 CFM per degree below the listed temperature.

NOTE: KW RATING IS FOR OUTDOOR AND INDOOR UNITS.

### HIGH CFM

| <b>Air Handler</b> | <b>Coil</b> | <b>T.C.</b> | <b>S.C.</b> | <b>KW</b> |
|--------------------|-------------|-------------|-------------|-----------|
| F*FV060            | -           | 0.95        | 1.00        | 0.95      |
| AV48               | -           | 0.95        | 1.00        | 0.95      |
| AV60               | -           | 0.95        | 1.00        | 0.95      |
| MV20D              | FC/MC60D    | 1.00        | 1.00        | 1.00      |
| MV20D              | FC/MC62D    | 1.01        | 1.01        | 1.01      |

| <b>Variable Speed Furnace</b> | <b>Coil</b> | <b>T.C.</b> | <b>S.C.</b> | <b>KW</b> |
|-------------------------------|-------------|-------------|-------------|-----------|
| P(C,V)9*D20                   | FC/MC/PC60D | 1.02        | 0.98        | 1.02      |
| P(C,V)9*D20                   | FC/MC62D    | 1.07        | 0.97        | 1.07      |
| PV8*C20                       | FC/PC60C    | 1.02        | 0.98        | 1.02      |
| P(C,V)9*C20                   | FC/PC60C    | 1.02        | 0.98        | 1.02      |
| P(C,V)9*D20                   | HC60        | 1.02        | 0.98        | 1.02      |
| PV8*C20                       | HC60        | 1.02        | 0.98        | 1.02      |
| P(C,V)9*D20                   | HD60        | 1.02        | 0.98        | 1.02      |
| P(C,V)9*D20                   | FC/MC62D    | 1.07        | 0.97        | 1.07      |
| P(C,V)9*C20                   | UC60C       | 1.02        | 0.98        | 1.02      |
| PV8*C20                       | UC60C       | 1.02        | 0.98        | 1.02      |
| P(C,V)9*D20                   | UC60D       | 1.02        | 0.98        | 1.02      |

| <b>COOLING PERFORMANCE DATA - LOW CFM 1-STAGE OPERATION</b> |                   |                      |      |      |      |      |      |      |      |      |      |      |      |      |      |      |
|---|-------------------|----------------------|------|------|------|------|------|------|------|------|------|------|------|------|------|------|
| <b>OUTDOOR UNIT MODEL NO.</b>                               |                   | <b>YZE06011</b>      |      |      |      |      |      |      |      |      |      |      |      |      |      |      |
| <b>INDOOR COIL MODEL NO.</b>                                |                   | <b>MC61D + MV20D</b> |      |      |      |      |      |      |      |      |      |      |      |      |      |      |
| <b>CONDENSER<br/>ENTERING AIR<br/>TEMPERATURE</b>           | <b>ID CFM</b>     | 1100                 |      |      |      |      | 1150 |      |      |      |      | 1200 |      |      |      |      |
|   | <b>ID DB (°F)</b> | 80                   | 80   | 75   | 80   | 80   | 80   | 80   | 75   | 80   | 80   | 80   | 80   | 75   | 80   | 80   |
|   | <b>ID WB (°F)</b> | 57                   | 62   | 62   | 67   | 72   | 57   | 62   | 62   | 67   | 72   | 57   | 62   | 62   | 67   | 72   |
| 65  | T.C.              | 37.0                 | 39.7 | 40.4 | 44.5 | 49.2 | 37.7 | 40.2 | 40.9 | 44.9 | 49.8 | 38.4 | 40.8 | 41.4 | 45.2 | 50.3 |
|   | S.C.              | 37.9                 | 34.8 | 29.7 | 29.4 | 24.3 | 38.6 | 36.1 | 30.4 | 30.1 | 23.9 | 39.2 | 37.3 | 31.1 | 30.7 | 23.6 |
|   | K.W.              | 2.1                  | 2.1  | 2.1  | 2.1  | 2.1  | 2.1  | 2.1  | 2.1  | 2.1  | 2.1  | 2.1  | 2.1  | 2.1  | 2.1  | 2.1  |
| 75  | T.C.              | 35.5                 | 37.7 | 38.3 | 42.3 | 46.9 | 36.1 | 38.2 | 38.7 | 42.7 | 47.3 | 36.8 | 38.7 | 39.1 | 43.1 | 47.8 |
|   | S.C.              | 36.3                 | 33.7 | 28.7 | 28.5 | 23.1 | 37.0 | 34.7 | 29.3 | 29.2 | 23.1 | 37.6 | 35.8 | 30.0 | 29.8 | 23.1 |
|   | K.W.              | 2.5                  | 2.5  | 2.5  | 2.5  | 2.5  | 2.5  | 2.5  | 2.5  | 2.5  | 2.5  | 2.5  | 2.5  | 2.5  | 2.5  | 2.5  |
| 85  | T.C.              | 34.0                 | 35.7 | 36.1 | 40.2 | 44.6 | 34.6 | 36.2 | 36.4 | 40.6 | 44.9 | 35.1 | 36.6 | 36.8 | 41.1 | 45.3 |
|   | S.C.              | 34.8                 | 32.5 | 27.7 | 27.7 | 21.9 | 35.4 | 33.4 | 28.3 | 28.3 | 22.3 | 36.0 | 34.3 | 28.9 | 28.9 | 22.6 |
|   | K.W.              | 2.9                  | 2.9  | 2.9  | 2.9  | 2.9  | 2.9  | 2.9  | 2.9  | 2.9  | 2.9  | 2.9  | 2.9  | 2.9  | 2.9  | 2.9  |
| 95  | T.C.              | 32.5                 | 33.7 | 33.9 | 38.0 | 42.3 | 33.0 | 34.1 | 34.2 | 38.5 | 42.5 | 33.5 | 34.5 | 34.5 | 39.0 | 42.7 |
|   | S.C.              | 33.3                 | 31.4 | 26.6 | 26.8 | 20.8 | 33.8 | 32.1 | 27.2 | 27.4 | 21.4 | 34.3 | 32.7 | 27.8 | 28.0 | 22.1 |
|   | K.W.              | 3.3                  | 3.3  | 3.3  | 3.3  | 3.3  | 3.3  | 3.3  | 3.3  | 3.3  | 3.3  | 3.3  | 3.3  | 3.3  | 3.3  | 3.3  |
| 105   | T.C.              | 30.7                 | 31.5 | 31.5 | 35.5 | 39.4 | 31.2 | 31.9 | 31.8 | 35.8 | 39.6 | 31.6 | 32.2 | 32.2 | 36.1 | 39.7 |
|   | S.C.              | 31.4                 | 30.1 | 25.6 | 25.7 | 19.9 | 31.9 | 30.7 | 26.2 | 26.3 | 20.5 | 32.4 | 31.3 | 26.8 | 27.0 | 21.0 |
|   | K.W.              | 3.8                  | 3.8  | 3.8  | 3.8  | 3.8  | 3.9  | 3.8  | 3.8  | 3.8  | 3.8  | 3.9  | 3.9  | 3.9  | 3.8  | 3.8  |
| 115   | T.C.              | 29.0                 | 29.3 | 29.3 | 33.1 | 36.5 | 29.4 | 29.7 | 29.5 | 33.2 | 36.7 | 29.8 | 30.0 | 29.8 | 33.3 | 36.8 |
|   | S.C.              | 29.7                 | 28.9 | 24.5 | 24.6 | 19.0 | 30.1 | 29.4 | 25.2 | 25.3 | 19.5 | 30.5 | 30.0 | 25.8 | 25.9 | 20.0 |
|   | K.W.              | 4.4                  | 4.4  | 4.4  | 4.4  | 4.4  | 4.4  | 4.4  | 4.4  | 4.4  | 4.4  | 4.4  | 4.4  | 4.4  | 4.4  | 4.4  |
| 125   | T.C.              | 27.3                 | 27.1 | 27.0 | 30.6 | 33.7 | 27.6 | 27.5 | 27.2 | 30.5 | 33.8 | 27.9 | 27.8 | 27.5 | 30.4 | 33.9 |
|   | S.C.              | 27.9                 | 27.6 | 23.4 | 23.6 | 18.2 | 28.2 | 28.1 | 24.1 | 24.2 | 18.5 | 28.5 | 28.6 | 24.9 | 24.9 | 18.9 |
|   | K.W.              | 4.9                  | 4.9  | 4.9  | 4.9  | 4.9  | 4.9  | 4.9  | 4.9  | 4.9  | 4.9  | 4.9  | 4.9  | 4.9  | 4.9  | 4.9  |

NOTE: ALL CAPACITIES ARE NET (KBTUH) WITH INDOOR FAN HEAT ALREADY DEDUCTED AT 1250 BTUH/1000 CFM.

### Multipliers for determining the performance with other indoor sections.

NOTE: For dry bulb temperatures different than those listed (between 73-87 F), sensible capacity increases by 1060 BTUH per 1000 CFM per degree above the listed temperature and decreases by 1060 BTUH per 1000 CFM per degree below the listed temperature.

NOTE: KW RATING IS FOR OUTDOOR AND INDOOR UNITS.

### LOW CFM

| <b>Air Handler</b> | <b>Coil</b> | <b>T.C.</b> | <b>S.C.</b> | <b>KW</b> |
|--------------------|-------------|-------------|-------------|-----------|
| F*FV060            | -           | 1.00        | 1.00        | 1.01      |
| AV60               | -           | 1.00        | 1.00        | 1.01      |
| MV20D              | FC/MC60D    | 1.00        | 1.00        | 1.01      |
| MV20D              | FC/MC62D    | 1.00        | 1.00        | 1.00      |

| <b>Variable Speed Furnace</b> | <b>Coil</b> | <b>T.C.</b> | <b>S.C.</b> | <b>KW</b> |
|-------------------------------|-------------|-------------|-------------|-----------|
| P(C,V)9*D20                   | FC/MC/PC60D | 0.98        | 0.94        | 1.01      |
| P(C,V)9*D20                   | FC/MC62D    | 0.98        | 1.01        | 1.01      |
| PV8*C20                       | FC/PC60C    | 0.98        | 0.94        | 1.01      |
| P(C,V)9*C20                   | FC/PC60C    | 0.98        | 1.01        | 1.01      |
| P(C,V)9*D20                   | HC60        | 0.98        | 0.94        | 1.01      |
| PV8*C20                       | HD60        | 0.98        | 1.01        | 1.01      |
| P(C,V)9*D20                   | HD60        | 0.99        | 0.94        | 1.01      |
| P(C,V)9*D20                   | FC/MC62D    | 0.99        | 1.01        | 1.01      |
| P(C,V)9*C20                   | UC60C       | 0.99        | 1.01        | 1.01      |
| PV8*C20                       | UC60C       | 0.99        | 1.01        | 1.01      |
| P(C,V)9*D20                   | UC60D       | 0.99        | 1.01        | 1.01      |

| <b>COOLING PERFORMANCE DATA - HIGH CFM 2-STAGE OPERATION</b> |                   |                      |      |      |      |      |      |      |      |      |      |      |      |      |      |      |
|--|-------------------|----------------------|------|------|------|------|------|------|------|------|------|------|------|------|------|------|
| <b>OUTDOOR UNIT MODEL NO.</b>                                |                   | <b>YZE06011</b>      |      |      |      |      |      |      |      |      |      |      |      |      |      |      |
| <b>INDOOR COIL MODEL NO.</b>                                 |                   | <b>MC61D + MV20D</b> |      |      |      |      |      |      |      |      |      |      |      |      |      |      |
| <b>CONDENSER ENTERING AIR TEMPERATURE</b>                    | <b>ID CFM</b>     | 1600                 |      |      |      |      | 1800 |      |      |      |      | 2000 |      |      |      |      |
|  | <b>ID DB (°F)</b> | 80                   | 80   | 75   | 80   | 80   | 80   | 80   | 75   | 80   | 80   | 80   | 80   | 75   | 80   | 80   |
|  | <b>ID WB (°F)</b> | 57                   | 62   | 62   | 67   | 72   | 57   | 62   | 62   | 67   | 72   | 57   | 62   | 62   | 67   | 72   |
| 65   | T.C.              | 53.2                 | 56.9 | 56.8 | 59.8 | 61.0 | 54.1 | 57.0 | 57.4 | 59.5 | 60.9 | 55.0 | 57.1 | 58.0 | 59.2 | 60.7 |
|  | S.C.              | 53.6                 | 50.4 | 42.0 | 41.8 | 29.6 | 54.6 | 51.9 | 43.0 | 41.7 | 29.8 | 55.6 | 53.4 | 44.0 | 41.5 | 30.1 |
|  | K.W.              | 3.5                  | 3.6  | 3.5  | 3.6  | 3.6  | 3.6  | 3.6  | 3.6  | 3.6  | 3.7  | 3.6  | 3.7  | 3.6  | 3.7  | 3.7  |
| 75   | T.C.              | 51.2                 | 54.1 | 54.1 | 57.8 | 60.2 | 52.0 | 54.4 | 54.6 | 57.7 | 60.2 | 52.8 | 54.6 | 55.1 | 57.6 | 60.2 |
|  | S.C.              | 51.7                 | 48.7 | 40.8 | 40.6 | 29.6 | 52.5 | 50.0 | 41.8 | 40.8 | 29.8 | 53.3 | 51.2 | 42.8 | 40.9 | 30.1 |
|  | K.W.              | 4.0                  | 4.0  | 4.0  | 4.1  | 4.1  | 4.0  | 4.1  | 4.1  | 4.1  | 4.2  | 4.1  | 4.1  | 4.1  | 4.2  | 4.2  |
| 85   | T.C.              | 49.2                 | 51.3 | 51.4 | 55.7 | 59.5 | 49.9 | 51.7 | 51.9 | 55.8 | 59.6 | 50.6 | 52.0 | 52.3 | 56.0 | 59.7 |
|  | S.C.              | 49.7                 | 47.0 | 39.6 | 39.3 | 29.5 | 50.4 | 48.0 | 40.6 | 39.8 | 29.8 | 51.1 | 48.9 | 41.6 | 40.3 | 30.1 |
|  | K.W.              | 4.4                  | 4.5  | 4.5  | 4.6  | 4.6  | 4.5  | 4.5  | 4.5  | 4.6  | 4.7  | 4.6  | 4.6  | 4.6  | 4.7  | 4.7  |
| 95   | T.C.              | 47.2                 | 48.6 | 48.7 | 53.6 | 58.7 | 47.8 | 49.0 | 49.1 | 54.0 | 58.9 | 48.4 | 49.5 | 49.4 | 54.4 | 59.1 |
|  | S.C.              | 47.8                 | 45.3 | 38.4 | 38.0 | 29.5 | 48.3 | 46.0 | 39.4 | 38.9 | 29.8 | 48.8 | 46.7 | 40.4 | 39.7 | 30.1 |
|  | K.W.              | 4.9                  | 4.9  | 4.9  | 5.0  | 5.1  | 5.0  | 5.0  | 5.0  | 5.1  | 5.2  | 5.0  | 5.1  | 5.0  | 5.2  | 5.2  |
| 105  | T.C.              | 44.4                 | 45.5 | 45.5 | 50.0 | 54.9 | 45.0 | 45.9 | 45.8 | 50.2 | 55.1 | 45.5 | 46.2 | 46.1 | 50.5 | 55.3 |
|  | S.C.              | 44.9                 | 43.3 | 36.9 | 36.7 | 28.2 | 45.4 | 43.9 | 37.8 | 37.5 | 28.4 | 45.8 | 44.5 | 38.7 | 38.2 | 28.7 |
|  | K.W.              | 5.6                  | 5.6  | 5.6  | 5.7  | 5.8  | 5.6  | 5.7  | 5.7  | 5.8  | 5.9  | 5.7  | 5.8  | 5.7  | 5.8  | 5.9  |
| 115  | T.C.              | 41.7                 | 42.6 | 42.4 | 46.4 | 51.1 | 42.2 | 42.8 | 42.6 | 46.5 | 51.3 | 42.7 | 43.0 | 42.8 | 46.6 | 51.5 |
|  | S.C.              | 42.1                 | 41.4 | 35.5 | 35.3 | 26.9 | 42.5 | 41.9 | 36.3 | 36.1 | 27.1 | 43.0 | 42.3 | 37.1 | 36.8 | 27.3 |
|  | K.W.              | 6.2                  | 6.3  | 6.2  | 6.4  | 6.5  | 6.3  | 6.3  | 6.3  | 6.4  | 6.5  | 6.4  | 6.4  | 6.4  | 6.5  | 6.6  |
| 125  | T.C.              | 38.9                 | 39.7 | 39.3 | 42.9 | 47.4 | 39.4 | 39.7 | 39.4 | 42.9 | 47.6 | 39.9 | 39.8 | 39.6 | 42.8 | 47.8 |
|  | S.C.              | 39.3                 | 39.5 | 34.1 | 34.0 | 25.6 | 39.7 | 39.8 | 34.8 | 34.7 | 25.8 | 40.1 | 40.2 | 35.5 | 35.3 | 26.0 |
|  | K.W.              | 6.9                  | 6.9  | 6.9  | 7.0  | 7.1  | 7.0  | 7.0  | 7.0  | 7.1  | 7.2  | 7.1  | 7.1  | 7.0  | 7.1  | 7.3  |

NOTE: ALL CAPACITIES ARE NET (KBTUH) WITH INDOOR FAN HEAT ALREADY DEDUCTED AT 1250 BTUH/1000 CFM.

### Multipliers for determining the performance with other indoor sections.

NOTE: For dry bulb temperatures different than those listed (between 73-87 F), sensible capacity increases by 1060 BTUH per 1000 CFM per degree above the listed temperature and decreases by 1060 BTUH per 1000 CFM per degree below the listed temperature.

NOTE: KW RATING IS FOR OUTDOOR AND INDOOR UNITS.

### HIGH CFM

| <b>Air Handler</b> | <b>Coil</b> | <b>T.C.</b> | <b>S.C.</b> | <b>KW</b> |
|--------------------|-------------|-------------|-------------|-----------|
| F*FV060            | -           | 0.99        | 0.96        | 1.01      |
| AV60               | -           | 0.99        | 0.96        | 1.01      |
| MV20D              | FC/MC60D    | 0.99        | 0.96        | 1.01      |
| MV20D              | FC/MC62D    | 1.00        | 1.00        | 1.00      |

| <b>Variable Speed Furnace</b> | <b>Coil</b> | <b>T.C.</b> | <b>S.C.</b> | <b>KW</b> |
|-------------------------------|-------------|-------------|-------------|-----------|
| P(C,V)9*D20                   | FC/MC/PC60D | 0.98        | 0.98        | 1.00      |
| P(C,V)9*D20                   | FC/MC62D    | 1.03        | 0.99        | 1.06      |
| PV8*C20                       | FC/PC60C    | 0.98        | 0.98        | 1.00      |
| P(C,V)9*C20                   | FC/PC60C    | 1.03        | 0.99        | 1.06      |
| P(C,V)9*D20                   | HC60        | 0.98        | 0.98        | 1.00      |
| PV8*C20                       | HD60        | 1.03        | 0.99        | 1.06      |
| P(C,V)9*D20                   | HD60        | 0.98        | 0.98        | 1.00      |
| P(C,V)9*D20                   | FC/MC62D    | 1.03        | 0.99        | 1.06      |
| P(C,V)9*C20                   | UC60C       | 1.03        | 0.99        | 1.06      |
| PV8*C20                       | UC60C       | 1.03        | 0.99        | 1.06      |
| P(C,V)9*D20                   | UC60D       | 1.03        | 0.99        | 1.06      |

| HEATING PERFORMANCE DATA - LOW CFM 1-STAGE OPERATION |   |                     |     |        |       |     |        |       |     |        |
|--|---|---------------------|-----|--------|-------|-----|--------|-------|-----|--------|
| OUTDOOR UNIT MODEL NO.                               |   | YZE02411            |     |        |       |     |        |       |     |        |
| INDOOR COIL MODEL NO.                                |   | FC/MC/PC36B + MV12B |     |        |       |     |        |       |     |        |
| AIR TEMP.<br>ENTERING<br>OUTDOOR<br>UNIT             | AIR TEMP.<br>ENTERING<br>INDOOR<br>COIL | ID CFM              |     |        |       |     |        |       |     |        |
|  |   | 550                 |     |        | 600   |     |        | 650   |     |        |
|  |   | MBTUH               | KW  | C.O.P. | MBTUH | KW  | C.O.P. | MBTUH | KW  | C.O.P. |
| 60   | 60                                      | 23.4                | 1.6 | 4.3    | 23.5  | 1.5 | 4.5    | 23.7  | 1.5 | 4.8    |
|  | 70                                      | 21.7                | 1.8 | 3.6    | 22.1  | 1.7 | 3.8    | 22.5  | 1.7 | 4.0    |
|  | 80                                      | 20.1                | 2.0 | 3.0    | 20.7  | 1.9 | 3.2    | 21.4  | 1.9 | 3.4    |
| 47   | 60                                      | 19.5                | 1.5 | 3.8    | 19.5  | 1.4 | 4.0    | 19.6  | 1.4 | 4.1    |
|  | 70                                      | 18.8                | 1.7 | 3.2    | 18.9  | 1.7 | 3.3    | 19.0  | 1.6 | 3.4    |
|  | 80                                      | 18.1                | 2.0 | 2.7    | 18.3  | 1.9 | 2.8    | 18.4  | 1.9 | 2.9    |
| 40   | 60                                      | 16.8                | 1.4 | 3.5    | 16.7  | 1.3 | 3.6    | 16.7  | 1.3 | 3.8    |
|  | 70                                      | 15.7                | 1.6 | 2.9    | 16.0  | 1.6 | 3.0    | 16.2  | 1.5 | 3.2    |
|  | 80                                      | 14.6                | 1.8 | 2.4    | 15.2  | 1.8 | 2.5    | 15.8  | 1.7 | 2.7    |
| 30   | 60                                      | 15.4                | 1.3 | 3.4    | 15.4  | 1.3 | 3.5    | 15.5  | 1.3 | 3.6    |
|  | 70                                      | 14.4                | 1.5 | 2.8    | 14.4  | 1.5 | 2.9    | 14.5  | 1.4 | 3.0    |
|  | 80                                      | 13.3                | 1.6 | 2.4    | 13.4  | 1.6 | 2.4    | 13.5  | 1.6 | 2.5    |
| 17   | 60                                      | 12.3                | 1.4 | 2.5    | 12.3  | 1.4 | 2.6    | 12.4  | 1.4 | 2.7    |
|  | 70                                      | 10.7                | 1.6 | 1.9    | 10.9  | 1.6 | 2.0    | 11.1  | 1.6 | 2.1    |
|  | 80                                      | 9.2                 | 1.8 | 1.5    | 9.5   | 1.8 | 1.5    | 9.8   | 1.8 | 1.6    |
| 10   | 60                                      | 10.5                | 1.4 | 2.2    | 10.7  | 1.4 | 2.3    | 10.8  | 1.3 | 2.4    |
|  | 70                                      | 9.4                 | 1.5 | 1.8    | 9.6   | 1.5 | 1.9    | 9.8   | 1.5 | 2.0    |
|  | 80                                      | 8.3                 | 1.6 | 1.5    | 8.5   | 1.6 | 1.6    | 8.8   | 1.6 | 1.6    |

NOTE: ALL CAPACITIES INCLUDE INDOOR FAN HEAT AT 1250 BTUH/1000 CFM.

**Multipliers for determining the performance with other indoor section.**

NOTE: KW RATING IS FOR OUTDOOR AND INDOOR UNITS.

**LOW CFM**

| Air Handler | Coil     | MBH  | KW   | COP  |
|-------------|----------|------|------|------|
| AV24        | -        | 1.00 | 1.00 | 1.00 |
| AV36        | -        | 1.00 | 1.00 | 1.00 |
| MV12B       | FC/MC30B | 1.00 | 1.00 | 1.00 |
| MV12B       | FC/MC35B | 1.00 | 1.00 | 1.00 |
| MV12B       | FC/MC36B | 1.00 | 1.00 | 1.00 |
| MV12B       | FC/MC42B | 1.00 | 1.00 | 1.00 |
| MV16C       | FC/MC35C | 1.00 | 1.00 | 1.00 |
| MV16C       | FC/MC42C | 1.00 | 1.00 | 1.00 |

| Variable Speed Furnace | Coil        | T.C. | S.C. | KW   |
|------------------------|-------------|------|------|------|
| PV8*A12                | FC/MC/PC30A | 0.95 | 0.96 | 0.99 |
| PV9*A12                | FC/MC/PC30A | 0.95 | 0.96 | 0.99 |
| P(C,V)9*B12            | FC/MC/PC30B | 0.95 | 0.96 | 0.99 |
| PV9*A12                | FC/MC/PC32A | 0.95 | 0.96 | 0.99 |
| P(C,V)9*B12            | FC/MC/PC35B | 0.95 | 0.96 | 0.99 |
| PV8*A12                | FC/MC/PC36A | 0.95 | 0.96 | 0.99 |
| PV9*A12                | FC/MC/PC36A | 0.95 | 0.96 | 0.99 |
| P(C,V)9*B12            | FC/MC/PC36B | 0.95 | 0.96 | 0.99 |
| P(C,V)9*B12            | FC/MC/PC42B | 0.95 | 0.96 | 0.99 |
| P(C,V)9*B12            | HC30        | 0.96 | 0.96 | 1.00 |
| P(C,V)9*B12            | HC36        | 0.95 | 0.96 | 0.99 |
| P(C,V)9*B12            | HD36        | 0.95 | 0.96 | 0.99 |
| PV8*A12                | UC30A       | 0.95 | 0.96 | 0.99 |
| P(C,V)9*B12            | UC30B       | 0.95 | 0.96 | 0.99 |
| PV8*A12                | UC36A       | 0.95 | 0.96 | 0.99 |
| P(C,V)9*B12            | UC36B       | 0.95 | 0.96 | 0.99 |
| P(C,V)9*B12            | UC42B       | 0.95 | 0.96 | 0.99 |

| HEATING PERFORMANCE DATA - HIGH CFM 2-STAGE OPERATION |   |                     |     |        |       |     |        |       |     |        |
|---|---|---------------------|-----|--------|-------|-----|--------|-------|-----|--------|
| OUTDOOR UNIT MODEL NO.                                |   | YZE02411            |     |        |       |     |        |       |     |        |
| INDOOR COIL MODEL NO.                                 |   | FC/MC/PC36B + MV12B |     |        |       |     |        |       |     |        |
| AIR TEMP.<br>ENTERING<br>OUTDOOR<br>UNIT              | AIR TEMP.<br>ENTERING<br>INDOOR<br>COIL | ID CFM              |     |        |       |     |        |       |     |        |
|   |   | 700                 |     |        | 800   |     |        | 900   |     |        |
|   |   | MBTUH               | KW  | C.O.P. | MBTUH | KW  | C.O.P. | MBTUH | KW  | C.O.P. |
| 60  | 60                                      | 33.2                | 2.1 | 4.7    | 33.2  | 2.0 | 4.9    | 33.2  | 1.9 | 5.2    |
|   | 70                                      | 31.9                | 2.3 | 4.0    | 32.0  | 2.2 | 4.2    | 32.1  | 2.1 | 4.5    |
|   | 80                                      | 30.6                | 2.6 | 3.5    | 30.8  | 2.5 | 3.7    | 31.0  | 2.3 | 3.9    |
| 47  | 60                                      | 25.1                | 2.0 | 3.7    | 25.8  | 1.9 | 3.9    | 26.4  | 1.8 | 4.2    |
|   | 70                                      | 24.2                | 2.3 | 3.1    | 25.0  | 2.2 | 3.4    | 25.8  | 2.1 | 3.6    |
|   | 80                                      | 23.3                | 2.5 | 2.7    | 24.2  | 2.4 | 2.9    | 25.2  | 2.4 | 3.1    |
| 40  | 60                                      | 23.2                | 2.0 | 3.4    | 23.3  | 1.9 | 3.6    | 23.4  | 1.8 | 3.8    |
|   | 70                                      | 21.6                | 2.4 | 2.6    | 21.4  | 2.2 | 2.8    | 21.1  | 2.0 | 3.1    |
|   | 80                                      | 20.0                | 2.8 | 2.1    | 19.4  | 2.5 | 2.2    | 18.8  | 2.2 | 2.5    |
| 30  | 60                                      | 20.4                | 1.9 | 3.1    | 20.6  | 1.8 | 3.3    | 20.8  | 1.8 | 3.4    |
|   | 70                                      | 21.6                | 2.3 | 2.8    | 21.8  | 2.2 | 2.9    | 21.9  | 2.1 | 3.0    |
|   | 80                                      | 22.9                | 2.7 | 2.5    | 22.9  | 2.6 | 2.6    | 23.0  | 2.4 | 2.8    |
| 17  | 60                                      | 16.9                | 1.8 | 2.7    | 16.6  | 1.8 | 2.7    | 16.3  | 1.7 | 2.8    |
|   | 70                                      | 15.6                | 2.0 | 2.3    | 15.6  | 1.9 | 2.4    | 15.6  | 1.9 | 2.4    |
|   | 80                                      | 14.3                | 2.1 | 2.0    | 14.6  | 2.1 | 2.1    | 15.0  | 2.1 | 2.1    |
| 10  | 60                                      | 13.6                | 1.7 | 2.3    | 13.4  | 1.7 | 2.3    | 13.3  | 1.7 | 2.3    |
|   | 70                                      | 13.3                | 2.1 | 1.9    | 13.3  | 2.0 | 1.9    | 13.3  | 2.0 | 2.0    |
|   | 80                                      | 13.1                | 2.4 | 1.6    | 13.2  | 2.3 | 1.7    | 13.4  | 2.2 | 1.8    |

NOTE: ALL CAPACITIES INCLUDE INDOOR FAN HEAT AT 1250 BTUH/1000 CFM.

#### Multipliers for determining the performance with other indoor section.

NOTE: KW RATING IS FOR OUTDOOR AND INDOOR UNITS.

#### HIGH CFM

| Air Handler | Coil     | MBH  | KW   | COP  |
|-------------|----------|------|------|------|
| AV24        | -        | 1.00 | 1.00 | 1.00 |
| AV36        | -        | 1.00 | 1.00 | 1.00 |
| MV12B       | FC/MC30B | 0.99 | 1.00 | 0.99 |
| MV12B       | FC/MC35B | 0.99 | 1.00 | 0.99 |
| MV12B       | FC/MC36B | 0.99 | 1.00 | 0.99 |
| MV12B       | FC/MC42B | 0.99 | 1.00 | 0.99 |
| MV16C       | FC/MC35C | 0.99 | 1.00 | 0.99 |
| MV16C       | FC/MC42C | 0.99 | 1.00 | 0.99 |

| Variable Speed Furnace | Coil        | T.C. | S.C. | KW   |
|------------------------|-------------|------|------|------|
| PV8*A12                | FC/MC/PC30A | 0.99 | 1.00 | 0.99 |
| PV9*A12                | FC/MC/PC30A | 0.99 | 1.00 | 0.99 |
| P(C,V)9*B12            | FC/MC/PC30B | 0.99 | 1.00 | 0.99 |
| PV9*A12                | FC/MC/PC32A | 0.99 | 1.00 | 0.99 |
| P(C,V)9*B12            | FC/MC/PC35B | 0.99 | 1.00 | 0.99 |
| PV8*A12                | FC/MC/PC36A | 0.99 | 1.00 | 0.99 |
| PV9*A12                | FC/MC/PC36A | 0.99 | 1.00 | 0.99 |
| P(C,V)9*B12            | FC/MC/PC36B | 0.99 | 1.00 | 0.99 |
| P(C,V)9*B12            | FC/MC/PC42B | 0.99 | 1.00 | 0.99 |
| P(C,V)9*B12            | HC30        | 0.99 | 1.00 | 0.99 |
| P(C,V)9*B12            | HC36        | 0.99 | 1.00 | 0.99 |
| P(C,V)9*B12            | HD36        | 0.99 | 1.00 | 0.99 |
| PV8*A12                | UC30A       | 0.99 | 1.00 | 0.99 |
| P(C,V)9*B12            | UC30B       | 0.99 | 1.00 | 0.99 |
| PV8*A12                | UC36A       | 0.99 | 1.00 | 0.99 |
| P(C,V)9*B12            | UC36B       | 0.99 | 1.00 | 0.99 |
| P(C,V)9*B12            | UC42B       | 0.99 | 1.00 | 0.99 |

| <b>HEATING PERFORMANCE DATA - LOW CFM 1-STAGE OPERATION</b> |                                       |                            |           |               |              |           |               |              |           |               |
|---|---------------------------------------|----------------------------|-----------|---------------|--------------|-----------|---------------|--------------|-----------|---------------|
| <b>OUTDOOR UNIT MODEL NO.</b>                               |                                       | <b>YZE03611</b>            |           |               |              |           |               |              |           |               |
| <b>INDOOR COIL MODEL NO.</b>                                |                                       | <b>FC/MC/PC48C + MV16C</b> |           |               |              |           |               |              |           |               |
| <b>AIR TEMP. ENTERING OUTDOOR UNIT</b>                      | <b>AIR TEMP. ENTERING INDOOR COIL</b> | <b>ID CFM</b>              |           |               |              |           |               |              |           |               |
|   |                                       | <b>750</b>                 |           |               | <b>800</b>   |           |               | <b>850</b>   |           |               |
|   |                                       | <b>MBTUH</b>               | <b>KW</b> | <b>C.O.P.</b> | <b>MBTUH</b> | <b>KW</b> | <b>C.O.P.</b> | <b>MBTUH</b> | <b>KW</b> | <b>C.O.P.</b> |
| 60  | 60                                    | 27.9                       | 1.8       | 4.6           | 28.2         | 1.7       | 4.8           | 28.5         | 1.7       | 5.0           |
|   | 70                                    | 26.6                       | 2.0       | 3.9           | 27.0         | 2.0       | 4.1           | 27.4         | 1.9       | 4.2           |
|   | 80                                    | 25.4                       | 2.2       | 3.3           | 25.9         | 2.2       | 3.5           | 26.4         | 2.1       | 3.6           |
| 47  | 60                                    | 25.4                       | 1.7       | 4.3           | 24.8         | 1.7       | 4.3           | 24.3         | 1.6       | 4.3           |
|   | 70                                    | 23.7                       | 2.0       | 3.5           | 23.6         | 1.9       | 3.6           | 23.5         | 1.9       | 3.7           |
|   | 80                                    | 22.0                       | 2.2       | 2.9           | 22.4         | 2.1       | 3.1           | 22.7         | 2.1       | 3.2           |
| 40  | 60                                    | 21.7                       | 1.7       | 3.7           | 21.9         | 1.7       | 3.8           | 22.1         | 1.6       | 4.0           |
|   | 70                                    | 20.8                       | 1.9       | 3.2           | 21.1         | 1.9       | 3.3           | 21.4         | 1.9       | 3.4           |
|   | 80                                    | 19.9                       | 2.2       | 2.7           | 20.3         | 2.1       | 2.8           | 20.7         | 2.1       | 2.9           |
| 30  | 60                                    | 19.9                       | 1.7       | 3.5           | 19.4         | 1.7       | 3.4           | 18.9         | 1.7       | 3.3           |
|   | 70                                    | 18.6                       | 1.9       | 2.9           | 18.3         | 1.9       | 2.9           | 18.1         | 1.9       | 2.8           |
|   | 80                                    | 17.2                       | 2.1       | 2.4           | 17.2         | 2.1       | 2.4           | 17.3         | 2.0       | 2.5           |
| 17  | 60                                    | 15.0                       | 1.7       | 2.6           | 15.0         | 1.6       | 2.7           | 15.1         | 1.6       | 2.7           |
|   | 70                                    | 14.3                       | 1.9       | 2.2           | 14.3         | 1.9       | 2.3           | 14.4         | 1.8       | 2.3           |
|   | 80                                    | 13.5                       | 2.1       | 1.9           | 13.6         | 2.1       | 1.9           | 13.7         | 2.0       | 2.0           |
| 10  | 60                                    | 13.6                       | 1.7       | 2.4           | 13.5         | 1.6       | 2.4           | 13.4         | 1.6       | 2.5           |
|   | 70                                    | 12.7                       | 1.9       | 2.0           | 12.6         | 1.8       | 2.0           | 12.6         | 1.8       | 2.0           |
|   | 80                                    | 11.7                       | 2.1       | 1.7           | 11.8         | 2.0       | 1.7           | 11.8         | 2.0       | 1.7           |

NOTE: ALL CAPACITIES INCLUDE INDOOR FAN HEAT AT 1250 BTUH/1000 CFM.

**Multipliers for determining the performance with other indoor sections.**

NOTE: KW RATING IS FOR OUTDOOR AND INDOOR UNITS.

**LOW CFM**

| <b>Air Handler</b> | <b>Coil</b> | <b>MBH</b> | <b>KW</b> | <b>COP</b> |
|--------------------|-------------|------------|-----------|------------|
| AV36               | –           | 1.00       | 1.00      | 1.00       |
| AV48               | –           | 1.00       | 1.00      | 1.00       |
| MV12B              | FC/MC35B    | 1.00       | 1.00      | 1.00       |
| MV12B              | FC/MC42B    | 1.00       | 1.00      | 1.00       |
| MV16C              | FC/MC48C    | 1.00       | 1.00      | 1.00       |
| MV12D              | FC/MC48D    | 1.00       | 1.00      | 1.00       |

| <b>Variable Speed Furnace</b> | <b>Coil</b> | <b>T.C.</b> | <b>S.C.</b> | <b>KW</b> |
|-------------------------------|-------------|-------------|-------------|-----------|
| P(C,V)9*B12                   | FC/MC/PC35B | 0.97        | 0.98        | 0.99      |
| PV8*B16                       | FC/MC/PC35B | 0.97        | 0.98        | 0.99      |
| P(C,V)9*C16                   | FC/MC/PC35C | 0.97        | 0.98        | 0.99      |
| PV8*C16                       | FC/MC/PC35C | 0.97        | 0.98        | 0.99      |
| PV8*C20                       | FC/MC/PC35C | 0.97        | 0.98        | 0.99      |
| P(C,V)9*C20                   | FC/MC/PC35C | 0.97        | 0.98        | 0.99      |
| PV8*B16                       | FC/MC/PC42B | 0.97        | 0.98        | 0.99      |
| P(C,V)9*B12                   | FC/MC/PC42B | 0.97        | 0.98        | 0.99      |
| P(C,V)9*C20                   | FC/MC/PC42C | 0.97        | 0.98        | 0.99      |
| P(C,V)9*C16                   | FC/MC/PC42C | 0.97        | 0.98        | 0.99      |
| PV8*C16                       | FC/MC/PC42C | 0.97        | 0.98        | 0.99      |

| <b>Variable Speed Furnace</b> | <b>Coil</b> | <b>T.C.</b> | <b>S.C.</b> | <b>KW</b> |
|-------------------------------|-------------|-------------|-------------|-----------|
| PV8*C20                       | FC/MC/PC42C | 0.97        | 0.98        | 0.99      |
| P(C,V)9*C20                   | FC/MC/PC48C | 0.97        | 0.98        | 0.99      |
| P(C,V)9*C16                   | FC/MC/PC48C | 0.97        | 0.98        | 0.99      |
| PV8*C16                       | FC/MC/PC48C | 0.97        | 0.98        | 0.99      |
| PV8*C20                       | FC/MC/PC48C | 0.97        | 0.98        | 0.99      |
| P(,V)9*D20                    | FC/MC/PC48D | 0.97        | 0.98        | 0.99      |
| PV8*C16                       | HC42        | 0.97        | 0.98        | 0.99      |
| PV8*C20                       | HC42        | 0.97        | 0.98        | 0.99      |
| PV8*B16                       | UC42B       | 0.97        | 0.98        | 0.99      |
| P(C,V)9*B12                   | UC42B       | 0.97        | 0.98        | 0.99      |
| PV8*C20                       | UC42C       | 0.97        | 0.98        | 0.99      |
| PV8*C16                       | UC42C       | 0.97        | 0.98        | 0.99      |
| P(C,V)9*C16                   | UC42C       | 0.97        | 0.98        | 0.99      |
| P(C,V)9*C20                   | UC42C       | 0.97        | 0.98        | 0.99      |
| P(C,V)9*C20                   | UC48C       | 0.97        | 0.98        | 0.99      |
| PV8*C20                       | UC48C       | 0.97        | 0.98        | 0.99      |
| PV8*C16                       | UC48C       | 0.97        | 0.98        | 0.99      |
| P(C,V)9*C16                   | UC48C       | 0.97        | 0.98        | 0.99      |
| P(,V)9*D20                    | UC48D       | 0.97        | 0.98        | 0.99      |

| HEATING PERFORMANCE DATA - HIGH CFM 2-STAGE OPERATION |   |                     |     |        |       |     |        |       |     |        |
|---|---|---------------------|-----|--------|-------|-----|--------|-------|-----|--------|
| OUTDOOR UNIT MODEL NO.                                |   | YZE03611            |     |        |       |     |        |       |     |        |
| INDOOR COIL MODEL NO.                                 |   | FC/MC/PC48C + MV16C |     |        |       |     |        |       |     |        |
| AIR TEMP.<br>ENTERING<br>OUTDOOR<br>UNIT              | AIR TEMP.<br>ENTERING<br>INDOOR<br>COIL | ID CFM              |     |        |       |     |        |       |     |        |
|   |   | 1100                |     |        | 1200  |     |        | 1300  |     |        |
|   |   | MBTUH               | KW  | C.O.P. | MBTUH | KW  | C.O.P. | MBTUH | KW  | C.O.P. |
| 60  | 60                                      | 37.7                | 2.6 | 4.3    | 38.4  | 2.5 | 4.5    | 39.1  | 2.4 | 4.7    |
|   | 70                                      | 36.7                | 2.8 | 3.8    | 37.2  | 2.7 | 4.0    | 37.8  | 2.7 | 4.1    |
|   | 80                                      | 35.7                | 3.0 | 3.4    | 36.0  | 3.0 | 3.6    | 36.5  | 2.9 | 3.7    |
| 47  | 60                                      | 34.5                | 2.4 | 4.2    | 34.3  | 2.4 | 4.3    | 34.2  | 2.3 | 4.3    |
|   | 70                                      | 32.9                | 2.7 | 3.6    | 33.0  | 2.6 | 3.7    | 33.2  | 2.6 | 3.8    |
|   | 80                                      | 31.3                | 2.9 | 3.1    | 31.7  | 2.9 | 3.2    | 32.1  | 2.8 | 3.3    |
| 40  | 60                                      | 30.4                | 2.3 | 3.8    | 30.7  | 2.3 | 3.9    | 31.0  | 2.3 | 4.0    |
|   | 70                                      | 29.3                | 2.6 | 3.3    | 29.8  | 2.5 | 3.4    | 30.4  | 2.5 | 3.5    |
|   | 80                                      | 28.3                | 2.9 | 2.9    | 29.0  | 2.8 | 3.0    | 29.7  | 2.8 | 3.1    |
| 30  | 60                                      | 25.6                | 2.2 | 3.4    | 24.6  | 2.1 | 3.4    | 23.7  | 2.0 | 3.4    |
|   | 70                                      | 25.7                | 2.5 | 3.0    | 25.1  | 2.4 | 3.0    | 24.5  | 2.4 | 3.0    |
|   | 80                                      | 25.9                | 2.8 | 2.7    | 25.6  | 2.7 | 2.8    | 25.3  | 2.7 | 2.8    |
| 17  | 60                                      | 20.8                | 2.1 | 2.9    | 20.9  | 2.1 | 2.9    | 21.0  | 2.1 | 2.9    |
|   | 70                                      | 19.9                | 2.3 | 2.5    | 20.8  | 2.4 | 2.6    | 21.8  | 2.4 | 2.7    |
|   | 80                                      | 18.9                | 2.6 | 2.2    | 20.7  | 2.6 | 2.3    | 22.6  | 2.7 | 2.5    |
| 10  | 60                                      | 19.3                | 2.1 | 2.7    | 19.7  | 2.1 | 2.7    | 20.1  | 2.1 | 2.8    |
|   | 70                                      | 17.9                | 2.4 | 2.2    | 19.1  | 2.4 | 2.4    | 20.3  | 2.4 | 2.5    |
|   | 80                                      | 16.4                | 2.6 | 1.9    | 18.5  | 2.6 | 2.1    | 20.5  | 2.6 | 2.3    |

NOTE: ALL CAPACITIES INCLUDE INDOOR FAN HEAT AT 1250 BTUH/1000 CFM.

#### Multipliers for determining the performance with other indoor sections.

NOTE: KW RATING IS FOR OUTDOOR AND INDOOR UNITS.

#### HIGH CFM

| Air Handler | Coil     | MBH  | KW   | COP  |
|-------------|----------|------|------|------|
| AV36        | —        | 1.00 | 1.00 | 1.00 |
| AV48        | —        | 1.01 | 1.00 | 1.01 |
| MV12B       | FC/MC35B | 1.00 | 1.00 | 1.00 |
| MV12B       | FC/MC42B | 1.00 | 1.00 | 1.00 |
| MV16C       | FC/MC48C | 1.00 | 1.00 | 1.00 |
| MV12D       | FC/MC48D | 1.00 | 1.00 | 1.00 |

| Variable Speed Furnace | Coil        | T.C. | S.C. | KW   |
|------------------------|-------------|------|------|------|
| P(C,V)9*B12            | FC/MC/PC35B | 1.00 | 1.00 | 1.00 |
| PV8*B16                | FC/MC/PC35B | 1.00 | 0.99 | 1.01 |
| P(C,V)9*C16            | FC/MC/PC35C | 1.00 | 1.00 | 1.00 |
| PV8*C16                | FC/MC/PC35C | 1.00 | 1.00 | 1.00 |
| PV8*C20                | FC/MC/PC35C | 1.00 | 0.99 | 1.01 |
| P(C,V)9*C20            | FC/MC/PC35C | 1.00 | 0.99 | 1.01 |
| PV8*B16                | FC/MC/PC42B | 1.00 | 1.00 | 1.00 |
| P(C,V)9*B12            | FC/MC/PC42B | 1.00 | 1.00 | 1.00 |
| P(C,V)9*C20            | FC/MC/PC42C | 1.00 | 1.00 | 1.00 |
| P(C,V)9*C16            | FC/MC/PC42C | 1.00 | 1.00 | 1.00 |
| PV8*C16                | FC/MC/PC42C | 1.00 | 1.01 | 0.99 |

| Variable Speed Furnace | Coil        | T.C. | S.C. | KW   |
|------------------------|-------------|------|------|------|
| PV8*C20                | FC/MC/PC42C | 1.00 | 1.00 | 1.00 |
| P(C,V)9*C20            | FC/MC/PC48C | 1.00 | 1.00 | 1.00 |
| P(C,V)9*C16            | FC/MC/PC48C | 1.00 | 1.00 | 1.00 |
| PV8*C16                | FC/MC/PC48C | 1.00 | 1.00 | 1.00 |
| PV8*C20                | FC/MC/PC48C | 1.00 | 1.00 | 1.00 |
| P(C,V)9*D20            | FC/MC/PC48D | 1.00 | 1.00 | 1.00 |
| PV8*C16                | HC42        | 1.00 | 1.00 | 1.00 |
| PV8*C20                | HC42        | 1.00 | 1.00 | 1.00 |
| PV8*B16                | UC42B       | 1.00 | 1.00 | 1.00 |
| P(C,V)9*B12            | UC42B       | 1.00 | 1.00 | 1.00 |
| PV8*C20                | UC42C       | 1.00 | 1.00 | 1.00 |
| PV8*C16                | UC42C       | 1.00 | 1.00 | 1.00 |
| P(C,V)9*C16            | UC42C       | 1.00 | 1.00 | 1.00 |
| P(C,V)9*C20            | UC42C       | 1.00 | 1.00 | 1.00 |
| P(C,V)9*C20            | UC48C       | 1.00 | 1.00 | 1.00 |
| PV8*C20                | UC48C       | 1.00 | 1.00 | 1.00 |
| PV8*C16                | UC48C       | 1.00 | 1.00 | 1.00 |
| P(C,V)9*C16            | UC48C       | 1.00 | 1.00 | 1.00 |
| P(C,V)9*D20            | UC48D       | 1.00 | 1.00 | 1.00 |

| <b>HEATING PERFORMANCE DATA - LOW CFM 1-STAGE OPERATION</b> |                                       |                            |           |               |              |           |               |              |           |               |
|---|---------------------------------------|----------------------------|-----------|---------------|--------------|-----------|---------------|--------------|-----------|---------------|
| <b>OUTDOOR UNIT MODEL NO.</b>                               |                                       | <b>YZE04811</b>            |           |               |              |           |               |              |           |               |
| <b>INDOOR COIL MODEL NO.</b>                                |                                       | <b>FC/MC/PC60D + MV20D</b> |           |               |              |           |               |              |           |               |
| <b>AIR TEMP. ENTERING OUTDOOR UNIT</b>                      | <b>AIR TEMP. ENTERING INDOOR COIL</b> | <b>ID CFM</b>              |           |               |              |           |               |              |           |               |
|   |                                       | <b>950</b>                 |           |               | <b>1000</b>  |           |               | <b>1050</b>  |           |               |
|   |                                       | <b>MBTUH</b>               | <b>KW</b> | <b>C.O.P.</b> | <b>MBTUH</b> | <b>KW</b> | <b>C.O.P.</b> | <b>MBTUH</b> | <b>KW</b> | <b>C.O.P.</b> |
| 60  | 60                                    | 38.9                       | 2.5       | 4.6           | 39.3         | 2.5       | 4.7           | 39.8         | 2.4       | 4.8           |
|   | 70                                    | 37.6                       | 2.8       | 4.0           | 37.8         | 2.7       | 4.1           | 38.1         | 2.7       | 4.2           |
|   | 80                                    | 36.2                       | 3.1       | 3.4           | 36.3         | 3.0       | 3.6           | 36.4         | 2.9       | 3.7           |
| 47  | 60                                    | 33.1                       | 2.4       | 4.1           | 33.2         | 2.3       | 4.2           | 33.4         | 2.3       | 4.3           |
|   | 70                                    | 31.3                       | 2.6       | 3.5           | 31.8         | 2.6       | 3.6           | 32.3         | 2.6       | 3.7           |
|   | 80                                    | 29.6                       | 2.9       | 3.0           | 30.4         | 2.8       | 3.1           | 31.2         | 2.8       | 3.2           |
| 40  | 60                                    | 29.4                       | 2.3       | 3.7           | 29.7         | 2.3       | 3.8           | 29.9         | 2.3       | 3.9           |
|   | 70                                    | 28.4                       | 2.7       | 3.1           | 28.7         | 2.6       | 3.2           | 28.9         | 2.6       | 3.3           |
|   | 80                                    | 27.4                       | 3.0       | 2.7           | 27.7         | 2.9       | 2.8           | 28.0         | 2.9       | 2.8           |
| 30  | 60                                    | 25.6                       | 2.2       | 3.4           | 25.5         | 2.2       | 3.4           | 25.5         | 2.2       | 3.4           |
|   | 70                                    | 24.3                       | 2.6       | 2.8           | 24.3         | 2.6       | 2.8           | 24.3         | 2.6       | 2.8           |
|   | 80                                    | 23.0                       | 2.9       | 2.3           | 23.0         | 2.9       | 2.3           | 23.1         | 2.9       | 2.3           |
| 17  | 60                                    | 19.7                       | 2.3       | 2.6           | 19.6         | 2.2       | 2.6           | 19.4         | 2.2       | 2.6           |
|   | 70                                    | 17.3                       | 2.6       | 2.0           | 17.2         | 2.5       | 2.0           | 17.0         | 2.5       | 2.0           |
|   | 80                                    | 15.0                       | 2.9       | 1.5           | 14.8         | 2.8       | 1.6           | 14.6         | 2.7       | 1.6           |
| 10  | 60                                    | 15.9                       | 2.2       | 2.1           | 15.9         | 2.2       | 2.1           | 15.9         | 2.2       | 2.1           |
|   | 70                                    | 14.9                       | 2.5       | 1.7           | 15.0         | 2.5       | 1.8           | 15.0         | 2.5       | 1.8           |
|   | 80                                    | 13.9                       | 2.8       | 1.4           | 14.0         | 2.8       | 1.5           | 14.1         | 2.7       | 1.5           |

NOTE: ALL CAPACITIES INCLUDE INDOOR FAN HEAT AT 1250 BTUH/1000 CFM.

**Multipliers for determining the performance with other indoor sections.**

NOTE: KW RATING IS FOR OUTDOOR AND INDOOR UNITS.

**LOW CFM**

| <b>Air Handler</b> | <b>Coil</b> | <b>MBH</b> | <b>KW</b> | <b>COP</b> |
|--------------------|-------------|------------|-----------|------------|
| F*FV060            | –           | 1.00       | 1.01      | 0.99       |
| AV48               | –           | 1.00       | 1.01      | 0.99       |
| AV60               | –           | 1.00       | 1.00      | 1.00       |
| MV20D              | FC/MC60D    | 1.00       | 1.01      | 0.99       |
| MV20D              | FC/MC62D    | 1.00       | 1.01      | 0.99       |

| <b>Variable Speed Furnace</b> | <b>Coil</b> | <b>T.C.</b> | <b>S.C.</b> | <b>KW</b> |
|-------------------------------|-------------|-------------|-------------|-----------|
| P(C,V)9*D20                   | FC/MC/PC60D | 0.98        | 0.99        | 0.99      |
| P(C,V)9*D20                   | FC/MC62D    | 0.98        | 0.99        | 0.99      |
| PV8*C20                       | FC/PC60C    | 0.98        | 0.99        | 0.99      |
| P(C,V)9*C20                   | FC/PC60C    | 0.98        | 0.99        | 0.99      |
| P(C,V)9*D20                   | HC60        | 0.98        | 0.99        | 0.99      |
| PV8*C20                       | HC60        | 0.98        | 0.99        | 0.99      |
| P(C,V)9*D20                   | HD60        | 0.98        | 0.99        | 0.99      |
| P(C,V)9*D20                   | FC/MC62D    | 0.98        | 0.99        | 0.99      |
| P(C,V)9*C20                   | UC60C       | 0.98        | 0.99        | 0.99      |
| PV8*C20                       | UC60C       | 0.98        | 0.99        | 0.99      |
| P(C,V)9*D20                   | UC60D       | 0.98        | 0.99        | 0.99      |

| HEATING PERFORMANCE DATA - HIGH CFM 2-STAGE OPERATION |   |                     |     |        |       |     |        |       |     |        |
|---|---|---------------------|-----|--------|-------|-----|--------|-------|-----|--------|
| OUTDOOR UNIT MODEL NO.                                |   | YZE04811            |     |        |       |     |        |       |     |        |
| INDOOR COIL MODEL NO.                                 |   | FC/MC/PC60D + MV20D |     |        |       |     |        |       |     |        |
| AIR TEMP.<br>ENTERING<br>OUTDOOR<br>UNIT              | AIR TEMP.<br>ENTERING<br>INDOOR<br>COIL | ID CFM              |     |        |       |     |        |       |     |        |
|   |   | 1500                |     |        | 1600  |     |        | 1700  |     |        |
|   |   | MBTUH               | KW  | C.O.P. | MBTUH | KW  | C.O.P. | MBTUH | KW  | C.O.P. |
| 60  | 60                                      | 60.1                | 3.5 | 5.0    | 60.5  | 3.5 | 5.0    | 61.0  | 3.5 | 5.1    |
|   | 70                                      | 58.6                | 3.9 | 4.4    | 58.9  | 3.8 | 4.5    | 59.3  | 3.8 | 4.5    |
|   | 80                                      | 57.2                | 4.2 | 4.0    | 57.4  | 4.2 | 4.0    | 57.6  | 4.2 | 4.1    |
| 47  | 60                                      | 48.7                | 3.2 | 4.4    | 49.2  | 3.2 | 4.5    | 49.6  | 3.2 | 4.5    |
|   | 70                                      | 47.7                | 3.6 | 3.9    | 48.0  | 3.6 | 4.0    | 48.4  | 3.5 | 4.0    |
|   | 80                                      | 46.6                | 3.9 | 3.5    | 46.8  | 3.9 | 3.5    | 47.1  | 3.9 | 3.5    |
| 40  | 60                                      | 44.4                | 3.2 | 4.1    | 44.4  | 3.1 | 4.2    | 44.3  | 3.1 | 4.2    |
|   | 70                                      | 43.0                | 3.5 | 3.6    | 42.9  | 3.5 | 3.6    | 42.8  | 3.4 | 3.6    |
|   | 80                                      | 41.6                | 3.8 | 3.2    | 41.4  | 3.8 | 3.2    | 41.2  | 3.8 | 3.2    |
| 30  | 60                                      | 35.5                | 3.0 | 3.5    | 34.4  | 2.9 | 3.5    | 33.3  | 2.9 | 3.4    |
|   | 70                                      | 33.9                | 3.2 | 3.1    | 33.6  | 3.2 | 3.0    | 33.3  | 3.3 | 3.0    |
|   | 80                                      | 32.3                | 3.5 | 2.7    | 32.8  | 3.6 | 2.7    | 33.2  | 3.7 | 2.7    |
| 17  | 60                                      | 28.5                | 2.9 | 2.9    | 28.6  | 2.8 | 3.0    | 28.8  | 2.8 | 3.0    |
|   | 70                                      | 27.3                | 3.3 | 2.5    | 27.6  | 3.2 | 2.5    | 27.9  | 3.2 | 2.6    |
|   | 80                                      | 26.1                | 3.6 | 2.1    | 26.6  | 3.6 | 2.2    | 27.1  | 3.5 | 2.2    |
| 10  | 60                                      | 25.0                | 2.8 | 2.7    | 24.0  | 2.8 | 2.5    | 23.0  | 2.8 | 2.4    |
|   | 70                                      | 22.5                | 3.2 | 2.1    | 23.1  | 3.2 | 2.1    | 23.8  | 3.2 | 2.2    |
|   | 80                                      | 19.9                | 3.6 | 1.6    | 22.2  | 3.6 | 1.8    | 24.5  | 3.6 | 2.0    |

NOTE: ALL CAPACITIES INCLUDE INDOOR FAN HEAT AT 1250 BTUH/1000 CFM.

#### Multipliers for determining the performance with other indoor sections.

NOTE: KW RATING IS FOR OUTDOOR AND INDOOR UNITS.

#### HIGH CFM

| Air Handler | Coil     | MBH  | KW   | COP  |
|-------------|----------|------|------|------|
| F*FV060     | —        | 0.99 | 1.00 | 0.99 |
| AV48        | —        | 0.99 | 1.00 | 0.99 |
| AV60        | —        | 1.00 | 1.00 | 1.00 |
| MV20D       | FC/MC60D | 0.99 | 1.00 | 0.99 |
| MV20D       | FC/MC62D | 0.99 | 1.00 | 0.99 |

| Variable Speed Furnace | Coil        | T.C. | S.C. | KW   |
|------------------------|-------------|------|------|------|
| P(C,V)9*D20            | FC/MC/PC60D | 1.00 | 1.00 | 1.00 |
| P(C,V)9*D20            | FC/MC62D    | 1.00 | 1.00 | 1.00 |
| PV8*C20                | FC/PC60C    | 1.00 | 1.00 | 1.00 |
| P(C,V)9*C20            | FC/PC60C    | 1.00 | 1.00 | 1.00 |
| P(C,V)9*D20            | HC60        | 1.00 | 1.00 | 1.00 |
| PV8*C20                | HC60        | 1.00 | 1.00 | 1.00 |
| P(C,V)9*D20            | HD60        | 1.00 | 1.00 | 1.00 |
| P(C,V)9*D20            | FC/MC62D    | 1.00 | 1.01 | 0.99 |
| P(C,V)9*C20            | UC60C       | 1.00 | 1.01 | 0.99 |
| PV8*C20                | UC60C       | 1.00 | 1.01 | 0.99 |
| P(C,V)9*D20            | UC60D       | 1.00 | 1.01 | 0.99 |

| HEATING PERFORMANCE DATA - LOW CFM 1-STAGE OPERATION |   |               |     |        |       |     |        |       |     |        |
|--|---|---------------|-----|--------|-------|-----|--------|-------|-----|--------|
| OUTDOOR UNIT MODEL NO.                               |   | YZE06011      |     |        |       |     |        |       |     |        |
| INDOOR COIL MODEL NO.                                |   | MC61D + MV20D |     |        |       |     |        |       |     |        |
| AIR TEMP.<br>ENTERING<br>OUTDOOR<br>UNIT             | AIR TEMP.<br>ENTERING<br>INDOOR<br>COIL | ID CFM        |     |        |       |     |        |       |     |        |
|  |   | 1100          |     |        | 1150  |     |        | 1200  |     |        |
|  |   | MBTUH         | KW  | C.O.P. | MBTUH | KW  | C.O.P. | MBTUH | KW  | C.O.P. |
| 60   | 60                                      | 44.8          | 3.1 | 4.2    | 45.8  | 3.1 | 4.3    | 46.7  | 3.1 | 4.4    |
|  | 70                                      | 44.4          | 3.6 | 3.7    | 44.9  | 3.5 | 3.7    | 45.5  | 3.5 | 3.8    |
|  | 80                                      | 44.0          | 4.0 | 3.2    | 44.1  | 4.0 | 3.3    | 44.3  | 3.9 | 3.3    |
| 47   | 60                                      | 38.6          | 3.1 | 3.7    | 38.6  | 3.0 | 3.8    | 38.7  | 2.9 | 3.9    |
|  | 70                                      | 37.4          | 3.4 | 3.2    | 37.6  | 3.4 | 3.3    | 37.8  | 3.3 | 3.3    |
|  | 80                                      | 36.2          | 3.8 | 2.8    | 36.6  | 3.8 | 2.8    | 36.9  | 3.7 | 2.9    |
| 40   | 60                                      | 34.0          | 3.0 | 3.3    | 34.4  | 2.9 | 3.4    | 34.8  | 2.9 | 3.6    |
|  | 70                                      | 33.3          | 3.4 | 2.9    | 33.5  | 3.3 | 3.0    | 33.8  | 3.2 | 3.1    |
|  | 80                                      | 32.7          | 3.7 | 2.6    | 32.7  | 3.6 | 2.6    | 32.8  | 3.6 | 2.7    |
| 30   | 60                                      | 24.7          | 2.9 | 2.5    | 23.3  | 2.8 | 2.4    | 21.9  | 2.8 | 2.3    |
|  | 70                                      | 25.8          | 3.3 | 2.3    | 24.9  | 3.3 | 2.2    | 23.9  | 3.2 | 2.2    |
|  | 80                                      | 26.8          | 3.7 | 2.1    | 26.4  | 3.7 | 2.1    | 26.0  | 3.6 | 2.1    |
| 17   | 60                                      | 22.6          | 2.8 | 2.4    | 22.4  | 2.8 | 2.4    | 22.1  | 2.7 | 2.4    |
|  | 70                                      | 20.5          | 3.1 | 2.0    | 20.3  | 3.0 | 2.0    | 20.0  | 3.0 | 1.9    |
|  | 80                                      | 18.4          | 3.4 | 1.6    | 18.2  | 3.3 | 1.6    | 17.9  | 3.3 | 1.6    |
| 10   | 60                                      | 16.8          | 2.6 | 1.9    | 16.6  | 2.6 | 1.9    | 16.5  | 2.6 | 1.9    |
|  | 70                                      | 17.1          | 3.0 | 1.7    | 16.9  | 3.0 | 1.7    | 16.7  | 2.9 | 1.7    |
|  | 80                                      | 17.4          | 3.4 | 1.5    | 17.1  | 3.4 | 1.5    | 16.9  | 3.3 | 1.5    |

NOTE: ALL CAPACITIES INCLUDE INDOOR FAN HEAT AT 1250 BTUH/1000 CFM.

**Multipliers for determining the performance with other indoor sections.**

NOTE: KW RATING IS FOR OUTDOOR AND INDOOR UNITS.

**LOW CFM**

| Air Handler | Coil     | MBH  | KW   | COP  |
|-------------|----------|------|------|------|
| F*FV060     | —        | 1.00 | 1.00 | 1.00 |
| AV60        | —        | 1.00 | 1.00 | 1.00 |
| MV20D       | FC/MC60D | 1.00 | 1.00 | 1.00 |
| MV20D       | FC/MC62D | 1.00 | 1.00 | 1.00 |

| Variable Speed Furnace | Coil        | T.C. | S.C. | KW   |
|------------------------|-------------|------|------|------|
| P(C,V)9*D20            | FC/MC/PC60D | 0.98 | 0.98 | 1.00 |
| P(C,V)9*D20            | FC/MC62D    | 0.98 | 0.98 | 1.00 |
| PV8*C20                | FC/PC60C    | 0.98 | 0.98 | 1.00 |
| P(C,V)9*C20            | FC/PC60C    | 0.98 | 0.98 | 1.00 |
| P(C,V)9*D20            | HC60        | 0.98 | 0.98 | 1.00 |
| PV8*C20                | HD60        | 0.98 | 0.98 | 1.00 |
| P(C,V)9*D20            | HD60        | 0.98 | 0.98 | 1.00 |
| P(C,V)9*D20            | FC/MC62D    | 0.98 | 0.99 | 1.00 |
| P(C,V)9*C20            | UC60C       | 0.98 | 0.99 | 1.00 |
| PV8*C20                | UC60C       | 0.98 | 0.99 | 1.00 |
| P(C,V)9*D20            | UC60D       | 0.98 | 0.99 | 1.00 |

| HEATING PERFORMANCE DATA - HIGH CFM 2-STAGE OPERATION |   |               |     |        |       |     |        |       |     |        |
|---|---|---------------|-----|--------|-------|-----|--------|-------|-----|--------|
| OUTDOOR UNIT MODEL NO.                                |   | YZE06011      |     |        |       |     |        |       |     |        |
| INDOOR COIL MODEL NO.                                 |   | MC61D + MV20D |     |        |       |     |        |       |     |        |
| AIR TEMP.<br>ENTERING<br>OUTDOOR<br>UNIT              | AIR TEMP.<br>ENTERING<br>INDOOR<br>COIL | ID CFM        |     |        |       |     |        |       |     |        |
|   |   | 1750          |     |        | 1850  |     |        | 1950  |     |        |
|   |   | MBTUH         | KW  | C.O.P. | MBTUH | KW  | C.O.P. | MBTUH | KW  | C.O.P. |
| 60  | 60                                      | 64.0          | 4.5 | 4.2    | 64.6  | 4.5 | 4.2    | 65.2  | 4.5 | 4.3    |
|   | 70                                      | 62.8          | 5.0 | 3.7    | 63.3  | 4.9 | 3.7    | 63.8  | 4.9 | 3.8    |
|   | 80                                      | 61.5          | 5.4 | 3.3    | 61.9  | 5.4 | 3.4    | 62.4  | 5.4 | 3.4    |
| 47  | 60                                      | 55.7          | 4.2 | 3.9    | 55.9  | 4.2 | 3.9    | 56.2  | 4.2 | 3.9    |
|   | 70                                      | 54.1          | 4.6 | 3.4    | 54.5  | 4.6 | 3.5    | 54.9  | 4.6 | 3.5    |
|   | 80                                      | 52.5          | 5.0 | 3.1    | 53.1  | 5.0 | 3.1    | 53.6  | 5.0 | 3.1    |
| 40  | 60                                      | 49.5          | 4.0 | 3.7    | 49.0  | 4.0 | 3.6    | 48.6  | 4.0 | 3.6    |
|   | 70                                      | 42.4          | 4.2 | 2.9    | 45.2  | 4.3 | 3.1    | 48.1  | 4.4 | 3.2    |
|   | 80                                      | 35.2          | 4.5 | 2.3    | 41.4  | 4.7 | 2.6    | 47.5  | 4.9 | 2.9    |
| 30  | 60                                      | 42.5          | 3.8 | 3.3    | 39.9  | 3.7 | 3.1    | 37.3  | 3.7 | 2.9    |
|   | 70                                      | 38.8          | 4.0 | 2.8    | 39.1  | 4.1 | 2.8    | 39.4  | 4.2 | 2.8    |
|   | 80                                      | 35.0          | 4.3 | 2.4    | 38.3  | 4.5 | 2.5    | 41.6  | 4.6 | 2.6    |
| 17  | 60                                      | 34.3          | 3.6 | 2.8    | 32.3  | 3.5 | 2.7    | 30.4  | 3.4 | 2.6    |
|   | 70                                      | 34.2          | 4.1 | 2.4    | 32.6  | 4.0 | 2.4    | 31.0  | 3.9 | 2.3    |
|   | 80                                      | 34.0          | 4.6 | 2.2    | 32.9  | 4.5 | 2.1    | 31.7  | 4.5 | 2.1    |
| 10  | 60                                      | 30.5          | 3.4 | 2.6    | 31.1  | 3.4 | 2.7    | 31.7  | 3.5 | 2.7    |
|   | 70                                      | 29.4          | 3.8 | 2.3    | 29.2  | 3.8 | 2.3    | 29.0  | 3.7 | 2.3    |
|   | 80                                      | 28.2          | 4.1 | 2.0    | 27.3  | 4.1 | 2.0    | 26.4  | 4.0 | 1.9    |

NOTE: ALL CAPACITIES INCLUDE INDOOR FAN HEAT AT 1250 BTUH/1000 CFM.

#### Multipliers for determining the performance with other indoor sections.

NOTE: KW RATING IS FOR OUTDOOR AND INDOOR UNITS.

#### HIGH CFM

| Air Handler | Coil     | MBH  | KW   | COP  |
|-------------|----------|------|------|------|
| F*FV060     | —        | 1.00 | 1.00 | 1.00 |
| AV60        | —        | 1.00 | 1.00 | 1.00 |
| MV20D       | FC/MC60D | 1.00 | 1.00 | 1.00 |
| MV20D       | FC/MC62D | 1.00 | 1.00 | 1.00 |

| Variable Speed Furnace | Coil        | T.C. | S.C. | KW   |
|------------------------|-------------|------|------|------|
| P(C,V)9*D20            | FC/MC/PC60D | 0.99 | 0.99 | 1.00 |
| P(C,V)9*D20            | FC/MC62D    | 0.99 | 0.99 | 1.00 |
| PV8*C20                | FC/PC60C    | 0.99 | 0.99 | 1.00 |
| P(C,V)9*C20            | FC/PC60C    | 0.99 | 0.99 | 1.00 |
| P(C,V)9*D20            | HC60        | 0.99 | 0.99 | 1.00 |
| PV8*C20                | HD60        | 0.99 | 0.99 | 1.00 |
| P(C,V)9*D20            | HD60        | 0.99 | 0.99 | 1.00 |
| P(C,V)9*D20            | FC/MC62D    | 0.99 | 0.99 | 1.00 |
| P(C,V)9*C20            | UC60C       | 0.99 | 0.99 | 1.00 |
| PV8*C20                | UC60C       | 0.99 | 0.99 | 1.00 |
| P(C,V)9*D20            | UC60D       | 0.99 | 0.99 | 1.00 |

# NOTES