



## Heating and Air Conditioning

### TECHNICAL GUIDE

#### SINGLE PIECE VARIABLE SPEED AIR HANDLERS

FOR USE WITH SPLIT-SYSTEM  
COOLING & HEAT PUMPS

MODELS: AVY24 THRU 60 AND SVY48 THRU 60

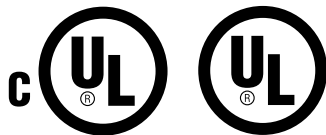

Due to continuous product improvement, specifications are subject to change without notice.

Visit us on the web at [www.york.com](http://www.york.com)

Additional rating information can be found at [www.ari.org/aridirectory](http://www.ari.org/aridirectory).

### DESCRIPTION

The deluxe Affinity fan coil line offers the ultimate in comfort, sound and application flexibility. The Affinity line of fan coils utilize a whisper quiet variable speed motor that provides humidity control and the lowest operating cost in the industry. The AVY air handler is shipped ready to be installed in all positions, upflow, downflow, horizontal left or right will, with minor adjustments. The SV 48 & 60 models are upflow only models designed into a shorter cabinet than the AV version, for those special applications where reduced height is required. No special kits are required to install this deluxe product in any position. This top of the line product was designed with the installer and homeowner in mind, easy to install and quiet, efficient and unsurpassed comfort for the end user.

All UPG air handlers and coils utilize a TXV to provide our customers with the optimum performance and refrigerant control required for 13+ systems. Air handlers can be ordered with a R22 TXV factory installed that can be easily converted to R410A by changing the bolt-on TXV. Air handlers are also available with "Flex-coils" without a factory installed metering device. For added flexibility a R22 or R410A TXV can be field installed to meet your refrigerant choice.

### FEATURE

**Thermal Expansion Valve** - Provides the ultimate refrigerant control required for today's high efficient product. The UPG bolt-on TXV provides the added flexibility to convert the air handler to the required refrigerant. The UPG TXV is a true bolt-on which does not require brazing to replace or install.

**MicroBlue™ Coated Fins** - All air handler coils are treated with the MicroBlue™ hydrophilic coating to enhance the removal of condensate during the refrigeration cycle and reduce the possibility of water blow-off. The MicroBlue™ coating also reduces the growth of germ causing microbes for a healthier home environment.

**Insulated Cabinet** - All air handler cabinets are thermally insulated with 1" foil faced insulation (R-4.2) to prevent sweating. For applications in extreme humidity conditions an optional, field installed, external insulating wrap kit is also available.

**Factory** - Sealed to achieve 2% or less leakage rate with or without field installed filter at 1.0" water gauge external static pressure.

**Durable Finish Inside and Out** - Air handler casings are made of pre-painted galvanized steel which provides a better paint to steel bond that resists corrosion and rust creep. All internal coil sheet metal parts are made of G90 pre-painted steel (i.e. triangular plates, top plates, horizontal supports etc). Coil header plates are not painted due to the brazing process during production. The coil header plates are treated after the brazing process with a corrosion resistant spray to reduce the probability of rust.

**New 4 HK Heat Kit** - Installation friendly, easy service, more robust, unique to new design.

**ECM Variable Speed Motor** - Designed for efficient, quiet operation with added indoor comfort control. With the use of a humidistat, the motor will monitor the humidity in the home and automatically keep the desired humidity level in both winter and summer seasons. The ECM motor utilizes only 24% of the energy used by standard blower motors which will reduce your overall heating and cooling costs.

**ClimaTrak Comfort Settings** - Installers can set an operating cycle for the ECM motor that works best in a particular climate. Homeowners benefit from an operating cycle that maximizes their indoor comfort level regardless of whether they live in a dry, temperate, or humid climate.

**DIMENSIONS**

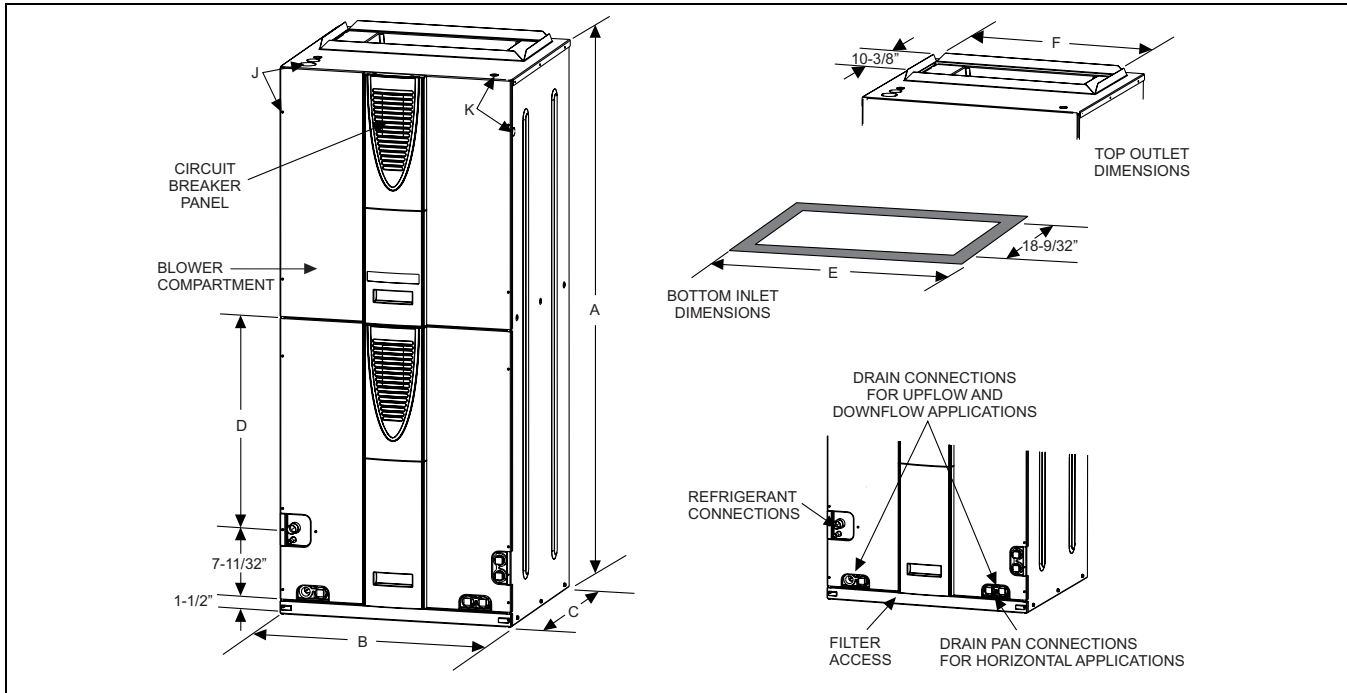

**DIMENSIONS**

Models	Dimensions (Inches)						Wiring Knockouts <sup>1</sup>		Refrigerant Connections Line Size			
	A	B	C	D	E	F	J	K	Liquid	Vapor		
	Height	Width	Depth				Power	Control				
AVY24B**H21	46	17.5	21.5 (w/o cladding)	12-3/8	13-29/32	14-19/32	7/8" (1/2") 1 3/8" (1") 1 23/32" (1 1/4")	7/8" (1/2")	3/8"	3/4"		
AVY36C**H21	52	21		17-1/8	17-13/32	18-3/32				7/8"		
AVY48D**H21	57	24.5		22-1/8	20-29/32	21-19/32				7/8"		
SVY48D**N21	52	24.5	22.5 (with cladding)	17-1/8	20-29/32	21-19/32				7/8"	3/8"	7/8"
AVY60D**H21	57	24.5		22-1/8	20-29/32	21-19/32						7/8"
SVY60D**N21	52	24.5		17-1/8	20-29/32	21-19/32						7/8"

1. Actual size (Conduit size).

**COIL TECHNICAL DATA**

Models	Application	Refrig. Conn. Types	Face Area (Sq. Ft.)	Rows Deep	Fin Per In.	Coil Size	Tube Geometry	Tube Dia.	Fin Type	TXV
AVY24B3XH21	Cooling / Heat Pump	Sweat	3.89	2	14	(2) 16 x 17.5	1 x 0.866	3/8	Enhanced	None
AVY24B2AH21			3.89	2	14					2A
AVY36C3XH21			4.86	3	12	(2) 20 x 17.5				None
AVY36C2AH21			4.86	3	12					2A
AVY48D3XH21			5.83	3	11	(2) 24 x 17.5				None
AVY48D2CH21			5.83	3	11					2C
SVY48D3XN21			5.83	3	11	(2) 24 x 17.5				None
SVY48D2CN21			5.83	3	11					2C
AVY60D3XH21			5.83	3	11	(2) 24 x 17.5				None
AVY60D2CH2			5.83	3	11					2C
SVY60D3XN21			5.83	3	11	(2) 24 x 17.5				None
SVY60D2CN21			5.83	3	11					2C

Note: H models are available with a factory installed horizontal drain pan.

**COOLING CAPACITY**

Models	Rated CFM	Entering Air °F (Dry / Wet Bulb)	MBH@ Evaporator Temperature and Corresponding Pressure °F / PSIG			
			35 / 61.5	40 / 68.5	45 / 76.0	50 / 84.0
<b>FULL-CASED "A" TYPE MULTI-POSITION</b>						
AVY24B2AH21	800	85/72	35.0	31.8	28.4	24.7
		80/67	32.2	29.1	25.7	22.3
		75/62	26.4	23.4	21.0	17.1
		70/57	21.4	18.6	20.2	12.1
AVY36C2AH21	1200	85/72	51.3	46.7	41.7	36.8
		80/67	41.1	36.3	31.8	27.1
		75/62	32.1	27.0	29.4	21.9
		70/57	27.6	25.4	23.5	18.3
AVY48D2CH21 SVY48D2CN21	1600	85/72	100.5	86.4	72.0	56.8
		80/67	80.4	67.5	55.0	42.1
		75/62	62.7	49.9	40.7	34.0
		70/57	53.9	47.2	36.81	28.71
AVY60D2CH21 SVY60D2CN21	1850	85/72	119.9	101.0	82.0	62.2
		80/67	96.0	79.2	62.6	45.8
		75/62	74.8	58.6	46.2	37.0
		70/57	64.3	55.4	43.2	33.7

**COOLING AIR FLOW DATA**

<b>HIGH / LOW SPEED COOLING AND HEAT PUMP CFM</b>					
AVY24B**H21		AVY36C**H21		JUMPER SETTINGS	
CFM		CFM			
High	Low	High	Low	COOL Tap	ADJ Tap*
1010	662	1230	873	A	B
816	534	1007	810	B	B
933	620	1202	811	A	A
706	460	903	640	B	A
926	615	1076	736	A	C
594	393	965	688	C	B
636	431	814	599	B	C
505	380	714	552	D	B
524	373	868	626	C	A
448	380	646	520	D	A
519	378	799	588	C	C
447	380	604	523	D	C
AVY48D**H21, SVY48D**N21		AVY60D**H21, SVY60D**N21		JUMPER SETTINGS	
CFM		CFM			
High	Low	High	Low	COOL Tap	ADJ Tap*
2020	1333	2166	1354	A	B
1759	1194	1970	1242	B	B
1989	1307	2134	1343	A	A
1607	1079	1769	1082	B	A
1790	1209	1895	1184	A	C
1502	1038	1826	1167	C	B
1439	1000	1526	978	B	C
1306	951	1654	1037	D	B
1368	973	1596	1025	C	A
1218	885	1434	928	D	A
1246	902	1397	934	C	C
1090	834	1283	861	D	C

All CFM's are shown at 0.5" w.c. external static pressure. These units have variable speed motors that automatically adjust to provide constant CFM from 0.0" to 0.6" w.c. static pressure. From 0.6" to 1.0" static pressure, CFM is reduced by 2% per 0.1" increase in static. Operation on duct systems with greater than 1.0" w.c. external static pressure is not recommended.

NOTE: At some settings, LOW COOL and/or LOW HEAT airflow may be lower than what is required to operate an airflow switch on certain models of electronic air cleaners. Consult the instructions for the electronic air cleaner for further details.

\* The ADJ "D" tap should not be used.

**HEATING AIR FLOW DATA**

HIGH / LOW HEAT CFM					
24B Air Handler		36C Air Handler		JUMPER SETTINGS	
CFM	CFM	CFM	CFM	HEAT Tap	ADJ Tap
High	Low	High	Low	A	A
933	681	1202	724	B	A
706	607	903	657	C	A
524	523	868	593	D	A
448	389	646	520		
48D Air Handler		60D Air Handler		JUMPER SETTINGS	
CFM	CFM	CFM	CFM	HEAT Tap	ADJ Tap
High	Low	High	Low	A	A
1942	1318	2134	1212	B	A
1607	1142	1769	1021	C	A
1358	927	1596	713	D	A
1305	673	1434	522		

All CFM's are shown at 0.5" w.c. external static pressure. These units have variable speed motors that automatically adjust to provide constant CFM from 0.0" to 0.6" w.c. static pressure. From 0.6" to 1.0" static pressure, CFM is reduced by 2% per 0.1" increase in static. Operation on duct systems with greater than 1.0" w.c. external static pressure is not recommended.  
NOTE: At some settings, LOW COOL and/or LOW HEAT airflow may be lower than what is required to operate an airflow switch on certain models of electronic air cleaners. Consult the instructions for the electronic air cleaner for further details.  
\* The ADJ "D" tap should not be used.

**APPLICATION FACTORS - RATED CFM VS. ACTUAL CFM**

% Of Rated Airflow	80%	90%	Rated CFM	110%	120%
Capacity Factor	0.96	0.98	1.00	1.02	1.03

**PHYSICAL & ELECTRICAL DATA - COOLING ONLY (60 Hz)**

Models	AVY24B**H21	AVY36C**H21	AVY48D**H21 SVY48D**N21	AVY60D**H21 SVY60D**N21
Blower - Diameter x Width	10 x 7	10 x 7	10 x 10	10 x 10
Motor	HP	1/3	1/2	3/4
	Nominal RPM	1200	1200	1200
Voltage	230			
Amps	Full Load (230)	2.8	4.3	5.5
	Type	DISPOSABLE OR PERMANENT		
Filter <sup>1</sup>	Size	16 x 20 x1	20 x 20 x1	22 x 20 x1
	Permanent Type Kit	1PF0601BK	1PF0602BK	1PF0603BK
Shipping / Operating Weight (lbs.)	140/134	170/164	AV - 196/185 SV - 194/181	AV - 199/188 SV - 195/184

1. Field supplied.

**ELECTRICAL DATA - COOLING ONLY (60 Hz)**

Models	Total Motor Amps		Minimum Circuit Ampacity		Max. O.C.P. Amps/Type <sup>1</sup>	Minimum Wire Size A.W.G.
	60 Hertz		60 Hertz			
	208V	230V	208V	230V		
AVY24B**H21	3.2	2.8	4.0	3.5	15	14
AVY36C**H21	4.7	4.3	5.9	5.4	15	14
AVY48D**H21	6.1	5.0	7.6	6.9	15	14
SVY48D**N21	6.1	5.0	7.6	6.9	15	14
AVY60D**H21	7.8	7.0	9.7	8.8	15	14
SVY60D**N21	7.8	7.0	9.7	8.8	15	14

1. OCP = Over Current Protection device, must be HACR type Circuit Breaker or Time Delay fuse.

**ELECTRICAL DATA - 208/230-1-60**

Models	Heat Kits*	Max. Static	Min. Speed Tap	Total Heat <sup>1</sup>				kW Staging					
				KW		MBH		W1 Only		W2 Only		W1 & W2	
				208v	240v	208v	240v	208v	240v	208v	240v	208v	240v
AVY24B**H21	4HK*6500206	0.5	Heat-D	1.9	2.5	6.4	8.5	1.9	2.5	1.9	2.5	1.9	2.5
	4HK*6500506	0.5	Heat-D	3.6	4.8	12.3	16.4	3.6	4.8	3.6	4.8	3.6	4.8
	4HK*6500806	0.5	Heat-D	5.6	7.5	19.2	25.6	2.8	3.75	5.6	7.5	5.6	7.5
	4HK*6501006	0.5	Heat-D	7.2	9.6	24.6	32.8	3.6	4.8	7.2	9.6	7.2	9.6
	4HK165N1506	0.5	Heat-D	10.8	14.4	36.9	49.1	3.6	4.8	7.2	9.6	10.8	14.4
AVY36C**H21	4HK*6500506	0.5	Heat-D	3.6	4.8	12.3	16.4	3.6	4.8	3.6	4.8	3.6	4.8
	4HK*6500806	0.5	Heat-D	5.6	7.5	19.2	25.6	2.8	3.75	5.6	7.5	5.6	7.5
	4HK*6501006	0.5	Heat-D	7.2	9.6	24.6	32.8	3.6	4.8	7.2	9.6	7.2	9.6
	4HK16501506	0.5	Heat-D	10.8	14.4	36.9	49.1	3.6	4.8	7.2	9.6	10.8	14.4
	4HK16501806	0.5	Heat-D	13.2	17.6	45.1	60.1	3.3	4.4	6.6	8.8	13.2	17.6
AVY48D**H21 SVY48D**N21	4HK*6500506	0.5	Heat-D	3.6	4.8	12.3	16.4	3.6	4.8	3.6	4.8	3.6	4.8
	4HK*6500806	0.5	Heat-D	5.6	7.5	19.2	25.6	2.8	3.75	5.6	7.5	5.6	7.5
	4HK*6501006	0.5	Heat-D	7.2	9.6	24.6	32.8	3.6	4.8	7.2	9.6	7.2	9.6
	4HK16501506	0.5	Heat-D	10.8	14.4	36.9	49.1	3.6	4.8	7.2	9.6	10.8	14.4
	4HK16501806	0.5	Heat-D	13.2	17.6	45.1	60.1	3.3	4.4	6.6	8.8	13.2	17.6
	4HK16502006	0.5	Heat-D	14.4	19.2	49.2	65.5	3.6	4.8	7.2	9.6	14.4	19.2
	4HK*6502506	0.5	Heat-D	18.0	24.0	61.5	81.9	3.6	4.8	10.8	14.4	18.0	24
AVY60D**H21 SVY60D**N21	4HK*6500506	0.5	Heat-D	3.6	4.8	12.3	16.4	3.6	4.8	3.6	4.8	3.6	4.8
	4HK*6500806	0.5	Heat-D	5.6	7.5	19.2	25.6	2.8	3.75	5.6	7.5	5.6	7.5
	4HK*6501006	0.5	Heat-D	7.2	9.6	24.6	32.8	3.6	4.8	7.2	9.6	7.2	9.6
	4HK16501506	0.5	Heat-D	10.8	14.4	36.9	49.1	3.6	4.8	7.2	9.6	10.8	14.4
	4HK16501806	0.5	Heat-D	13.2	17.6	45.1	60.1	3.3	4.4	6.6	8.8	13.2	17.6
	4HK16502006	0.5	Heat-D	14.4	19.2	49.2	65.5	3.6	4.8	7.2	9.6	14.4	19.2
	4HK16502506	0.5	Heat-D	18.0	24.0	61.5	81.9	3.6	4.8	10.8	14.4	18.0	24

1. See conversion Table 10.

\* May be 0 (no breaker) or 1 (with breaker).

**KW & MBH CONVERSIONS - FOR TOTAL POWER INPUT REQUIREMENT**

FOR	208V	OPERATION MULTIPLY	240V	TABULATED KW & MBH BY	.751
	230V		240V		.918
	220V		240V		.840

**COMFORT SETTINGS SELECTION**

Delay Tap	Comfort Setting
A	Normal
B	Humid
C	Dry
D	Temperate

**ELECTRICAL DATA (FOR SINGLE SOURCE POWER SUPPLY) - COPPER WIRE 208/230-1-60**

Models	Heat Kit - Single Phase*	Heater Amps 240V	Field Wiring					
			Min. Circuit Ampacity		Max. O.C.P. Amps/Type <sup>1</sup>		75°C Wire Size - AWG	
			208V	240V	208V	240V	208V	240V
AVY24B**H21	4HK*6500206	10.4	15.28	16.53	20	20	12	12
	4HK*6500506	20.0	25.67	28.50	30	30	10	10
	4HK*6500806	31.3	37.85	42.63	45	45	8	8
	4HK*6501006	40.0	47.33	53.50	50	60	8	6
	4HK165N1506	60.0	69.00	78.50	70	90	4	3
AVY36C**H21	4HK*6500506	20.0	27.54	30.38	30	35	10	10
	4HK*6500806	31.3	39.73	44.50	45	45	8	8
	4HK*6501006	40.0	49.21	55.38	50	60	8	6
	4HK16501506	60.0	70.88	80.38	70	90	4	3
	4HK16501806	73.3	85.32	97.00	90	100	4	3
AVY48D**H21 SVY48D**N21	4HK*6500506	20.0	29.29	31.88	35	35	8	8
	4HK*6500806	31.3	41.48	46.00	45	50	8	8
	4HK*6501006	40.0	50.96	56.88	60	60	6	6
	4HK16501506	60.0	72.63	81.88	90	90	3	3
	4HK16501806	73.3	87.07	98.50	90	100	3	2
	4HK16502006	80.0	94.29	106.88	100	125	3	1
	4HK16502506	100.0	115.96	131.88	125	150	1	1/0
AVY60D**H21 SVY60D**N21	4HK*6500506	20.0	31.42	33.75	35	35	8	8
	4HK*6500806	31.3	43.60	47.88	45	50	8	8
	4HK*6501006	40.0	53.08	58.75	60	60	6	6
	4HK16501506	60.0	74.75	83.75	90	90	3	3
	4HK16501806	73.3	89.19	100.38	90	110	3	2
	4HK16502006	80.0	96.42	108.75	100	125	3	1
	4HK16502506	100.0	118.08	133.75	125	150	1	1/0

1. O.C.P. = Over Current Protection device, must be HACR type Circuit Breaker or Time Delay fuse.

\* May be 0 (no breaker) or 1 (with breaker).

**ELECTRICAL DATA (FOR MULTI SOURCE POWER SUPPLY) - COPPER WIRE 208/230-1-60**

Models	Heater Model	Min. Circuit Ampacity			Max. O.C.P. Amps/Type <sup>1</sup>			75°C Wire Size - AWG		
		Circuit			Circuit			Circuit		
		1st	2nd	3rd	1st	2nd	3rd	1st	2nd	3rd
		208/240	208/240	208/240	208/240	208/240	208/240	208/240	208/240	208/240
AVY24B**H21	4HK165N1506	47.5 / 53.5	21.7 / 25.0	—	50 / 60	25 / 25	—	8 / 6	10 / 10	—
AVY36C**H21	4HK16501506	48.5 / 55.4	21.7 / 25.0	—	50 / 60	25 / 25	—	8 / 6	10 / 10	—
	4HK16501806	44.9 / 51.2	39.8 / 45.8	—	45 / 60	40 / 50	—	8 / 8	8 / 8	—
AVY48D**H21 SVY48D**N21	4HK16501506	51.0 / 56.9	21.7 / 25.0	—	60 / 60	25 / 25	—	6 / 6	10 / 10	—
	4HK16501806	47.4 / 52.7	39.8 / 45.8	—	50 / 60	40 / 60	—	6 / 6	8 / 6	—
	4HK16502006	51.0 / 56.9	43.4 / 50.0	—	60 / 60	45 / 50	—	6 / 6	8 / 8	—
	4HK16502506	51.0 / 56.9	43.4 / 50.0	21.7 / 25.0	60 / 60	45 / 50	25 / 25	6 / 6	8 / 8	10 / 10
AVY60D**H21 SVY60D**N21	4HK16501506	53.1 / 58.8	21.7 / 25.0	—	60 / 60	25 / 25	—	6 / 6	10 / 10	—
	4HK16501806	49.5 / 54.6	39.8 / 45.8	—	50 / 60	40 / 60	—	6 / 6	8 / 6	—
	4HK16502006	53.1 / 58.8	43.4 / 50.0	—	60 / 60	45 / 50	—	6 / 6	8 / 8	—
	4HK16502506	53.1 / 58.8	43.4 / 50.0	21.7 / 25.0	60 / 60	45 / 50	25 / 25	6 / 6	8 / 8	10 / 10

1. O.C.P. = Over Current Protection device, must be HACR type Circuit Breaker or Time Delay fuse.

**ELECTRICAL DATA - 208/230-3-60**

Models	Heat Kit - Three Phase	Max. Static	Min. Speed Tap	Total Heat <sup>1</sup>				KW Staging					
				KW		MBH		W1 Only		W2 Only		W1 + W2	
				208V	240V	208V	240V	208V	240V	208V	240V	208V	240V
AVY24B**H21	4HK06501025	0.5	Heat-D	7.2	9.6	24.6	32.8	7.2	9.6	7.2	9.6	7.2	9.6
AVY36C**H21	4HK06501025	0.5	Heat-D	7.2	9.6	24.6	32.8	7.2	9.6	7.2	9.6	7.2	9.6
	4HK06501525	0.5	Heat-D	10.8	14.4	36.9	49.1	10.8	14.4	10.8	14.4	10.8	14.4
AVY48D**H21 SVY48D**N21	4HK06501025	0.5	Heat-D	7.2	9.6	24.6	32.8	7.2	9.6	7.2	9.6	7.2	9.6
	4HK06501525	0.5	Heat-D	10.8	14.4	36.9	49.1	10.8	14.4	10.8	14.4	10.8	14.4
	4HK06501825	0.5	Heat-D	12.9	17.2	44.7	58.7	12.9	17.2	12.9	17.2	12.9	17.2
AVY60D**H21 SVY60D**N21	4HK06501025	0.5	Heat-D	7.2	9.6	24.6	32.8	7.2	9.6	7.2	9.6	7.2	9.6
	4HK06501525	0.5	Heat-D	10.8	14.4	36.9	49.1	10.8	14.4	10.8	14.4	10.8	14.4
	4HK16502525	0.5	Heat-D	18.0	24.0	61.4	81.4	9.0	12.0	18.0	24.0	18.0	24.0

1. See conversion table on Page 5.

**ELECTRICAL DATA (FOR SINGLE SOURCE POWER SUPPLY) - COPPER WIRE 208/230-3-60**

Models	Heat Kit - Three Phase	Heater Amps 240V	Field Wiring					
			Min. Circuit Ampacity		Max. O.C.P. <sup>1</sup> Amps/Type		75°C Wire Size - AWG	
			208V	240V	208V	240V	208V	240V
AVY24B**H21	4HK06501025	23.1	28.5	32.4	30	35	10	8
AVY36C**H21	4HK06501025	23.1	30.4	34.3	30	35	10	8
	4HK06501525	34.7	42.9	48.8	45	50	8	8
AVY48D**H21 SVY48D**N21	4HK06501025	23.1	31.3	35.1	35	35	8	8
	4HK06501525	34.7	43.8	49.6	45	50	8	8
	4HK06501825	41.4	51.0	58.0	60	60	6	6
AVY60D**H21 SVY60D**N21	4HK06501025	23.1	33.8	37.6	35	40	8	8
	4HK06501525	34.7	46.3	52.1	50	60	8	6

1. O.C.P. = Over Current Protection device, must be HACR type Circuit Breaker or Time Delay fuse.

**ELECTRICAL DATA (FOR MULTI SOURCE POWER SUPPLY) - COPPER WIRE 208/230-3-60**

Models	Heater Model	Minimum Circuit Ampacity			Max. O.C.P. <sup>1</sup> Amps/Type			75°C Wire Size - AWG		
		Circuit								
		1st	2nd	3rd	1st	2nd	3rd	1st	2nd	3rd
AVY60D**H21 SVY60D**N21	4HK16502525	41.0 / 44.9	31.3 / 36.1	- / -	45 / 45	35 / 40	- / -	8 / 8	8 / 8	- / -

1. O.C.P. = Over Current Protection device, must be HACR type Circuit Breaker or Time Delay fuse.

**ACCESSORIES**

Refer to Price Manual for specific model numbers.

**TXV Kits** - TXV kits are available for “Flex-coil” applications and converting R22 to R410A or as a service replacement. All kits are bolt-on and require no brazing to install.

**Non-Combustible Bases** - A combustible floor base accessory is available, if required by local codes, when the air handler is installed in the down flow position on a combustible material.

**Electric Heaters** - 4HK models shown under electrical data include sequential operation and temperature dual limit switches for safe, efficient operation. Circuit breakers are provided where shown.

**External Insulating Wrap Kit** - Provides a vinyl covered thermal insulation wrap, providing additional thermal insulation protection to prevent sweating in applications where extreme high humidity is present. Air Handler cover (or wrap) has Velcro edges for easy installation and access.

**LIMITATIONS**

These units must be wired and installed in accordance with all national and local safety codes.

Voltage limits are as follows:

Air Handler Voltage	Voltage code	<sup>1</sup> Normal Operating Voltage Range
208/230-1-60	06	187-253

1. Rated in accordance with ARI Standard 110, utilization range “A”.

Airflow must be within the minimum and maximum limits approved for electric heat, evaporator coils and outdoor units.

Entering Air Temperature Limits			
Wet Bulb Temp. °F		Dry Bulb Temp. °F	
Min.	Max.	Min.	Max.
57	72	65	95

**COOLING MODELS WITH ELECTRIC HEAT WIRING**

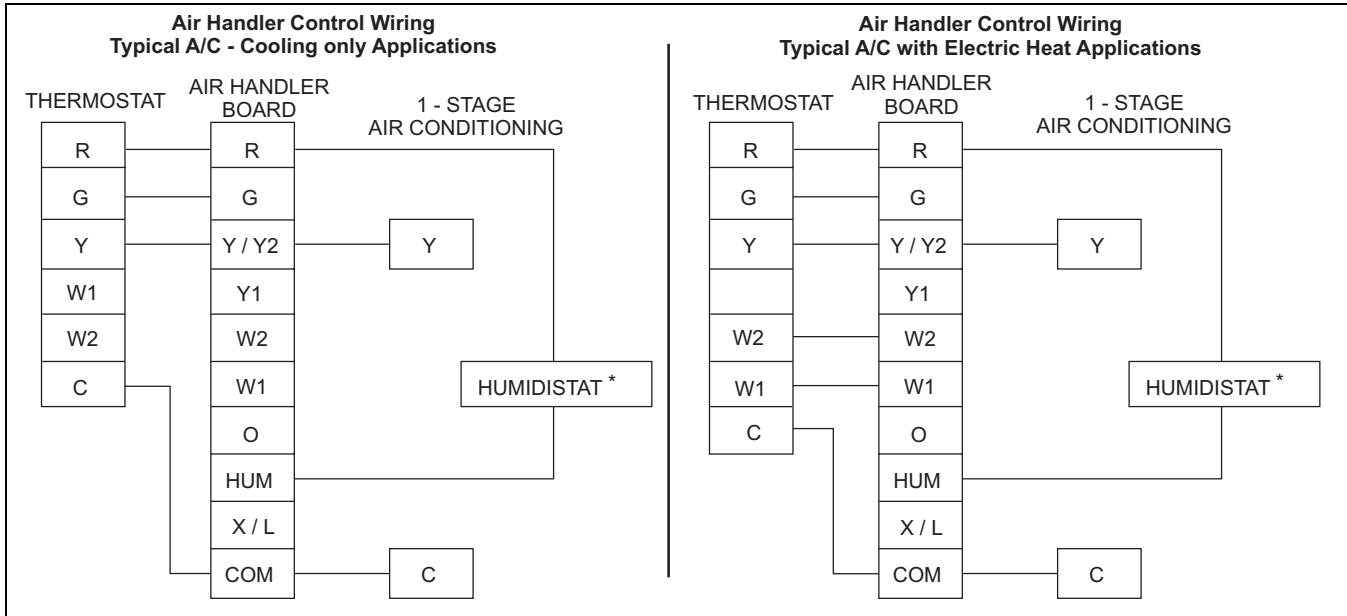

\* Optional dehumidification humidistat switch contacts open on humidity rise.

**NOTES:**

1. “Y/Y2” Terminal on air handler control board must be connected for full CFM and applications requiring 60 second blower off delay for SEER enhancement.
2. Remove humidistat jumper on air handler control board.
3. For heat pump applications - set MODE jumper on air handler control board to the HP position.
4. To change quantity of heat during HP defrost cycle - reverse connections at W1 and W2 on air handler control board.

**TWO-STAGE COOLING WIRING**

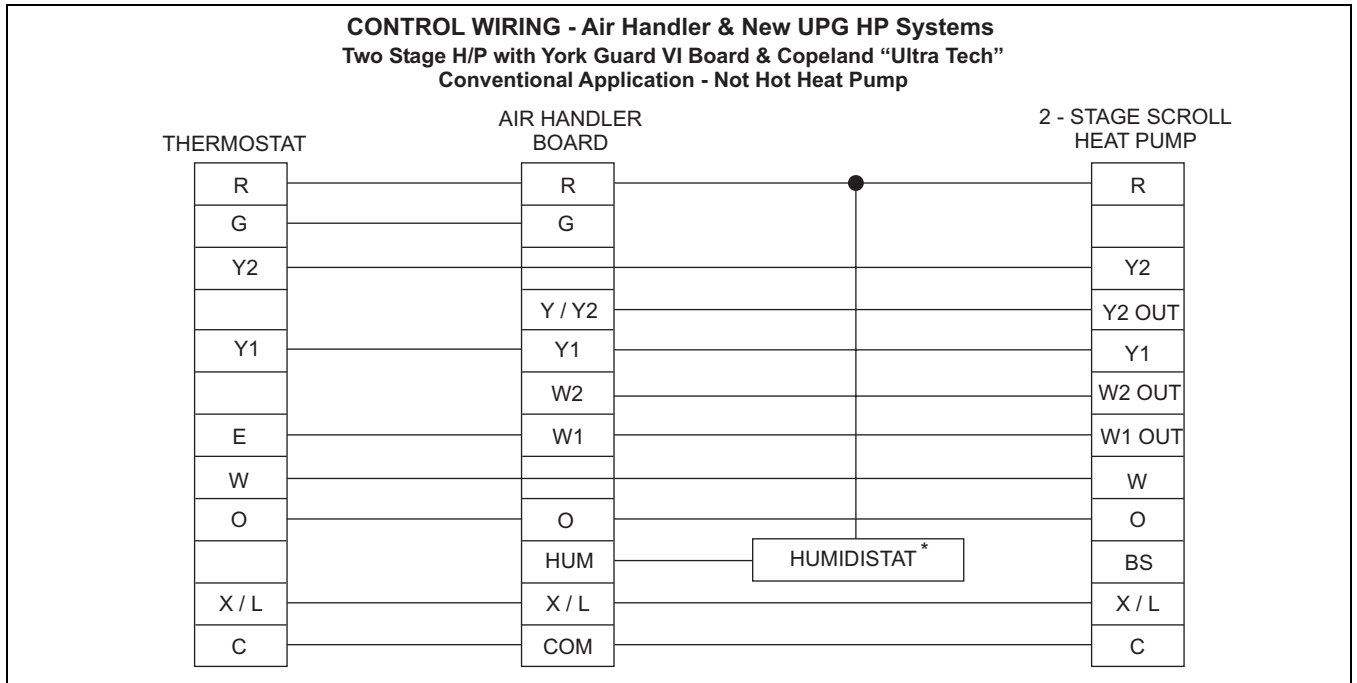

\* Optional dehumidification humidistat switch contacts open on humidity rise.

**NOTES:**

1. "Y/Y2" Terminal on air handler control board must be connected for full CFM and applications requiring 60 second blower off delay for SEER enhancement.
2. Remove humidistat jumper on air handler control board.
3. For heat pump applications - set MODE jumper on air handler control board to the HP position.
4. To change quantity of heat during HP defrost cycle - reverse connections at W1 and W2 on air handler control board.

**TYPICAL APPLICATIONS**

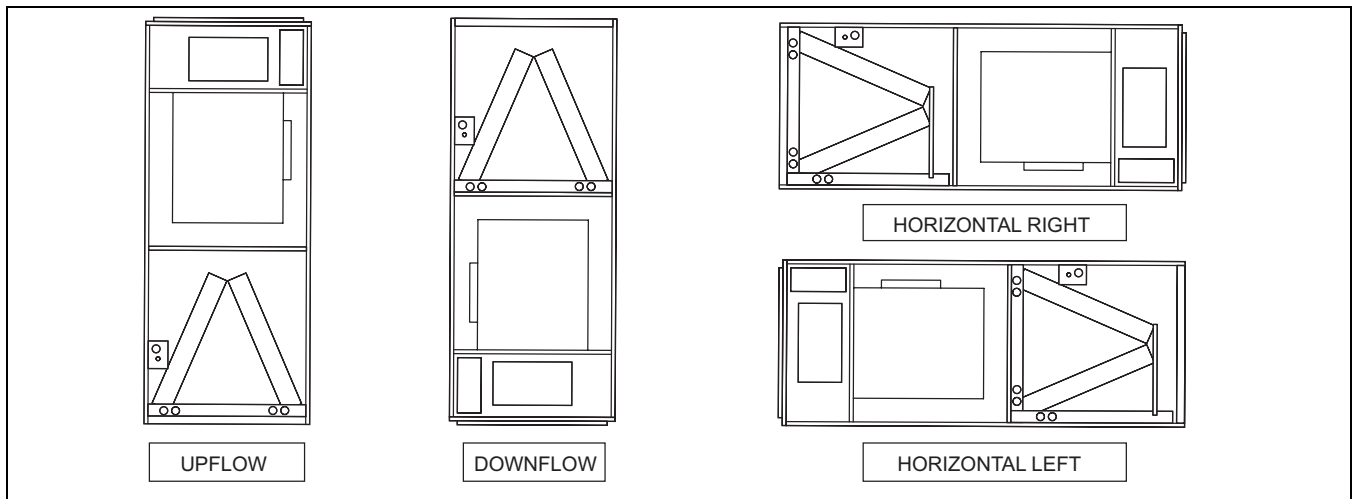

**NOTES**

## NOTES

# NOTES

Subject to change without notice. Printed in U.S.A.  
Copyright © by Unitary Products Group. 2008. All rights reserved.

256819-YTG-H-0108  
Supersedes: 256819-YTG-G-0507

---

**Unitary  
Products  
Group**

**5005  
York  
Drive**

**Norman  
OK  
73069**