



## TECHNICAL GUIDE

### 80% MODULATING (ECM MOTOR) GAS-FIRED RESIDENTIAL MULTI-POSITION GAS FURNACES STANDARD & Low NOx MODELS

MODELS: YP8C / YPLC

NATURAL GAS  
60 - 120 MBH INPUT

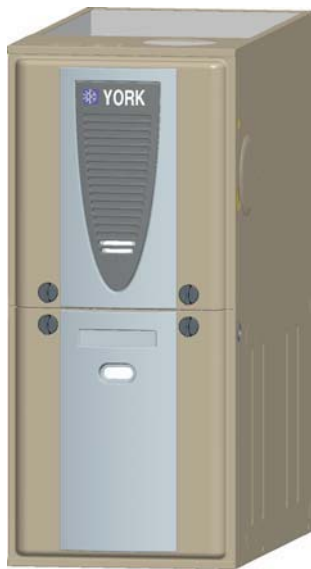

Due to continuous product improvement, specifications are subject to change without notice.

Visit us on the web at [www.york.com](http://www.york.com) for the most up-to-date technical information.

Additional efficiency rating information can be found at [www.gamanet.org](http://www.gamanet.org).

## DESCRIPTION

These compact units employ induced combustion, reliable hot surface ignition and high heat transfer aluminized tubular heat exchangers. The units are factory shipped for installation in upflow or horizontal applications and may be converted for downflow applications.

These furnaces are designed for residential installation in a basement, closet, alcove, attic, recreation room or garage and are also ideal for commercial applications. All units are factory assembled, wired and tested to assure safe dependable and economical installation and operation.

These units are Category I listed and may be common vented with another gas appliance as allowed by the National Fuel Gas Code.

## WARRANTY

Lifetime limited warranty on both heat exchangers to the original purchaser; a 20-year limited warranty from original installation date to subsequent purchaser.

10-year warranty on the heat exchanger in commercial applications.

5-year limited parts warranty.

## FEATURES

- Modulating heating operation includes:
  - Modulating gas valve, inducer and circulating blower
  - Modulating operation from 100% input to 50% input in 1% increments
- Easily applied in upflow, horizontal left or right, or downflow installation with minimal conversion necessary.
- Compact, easy to install, ideal height 33" tall cabinet.
- ECM variable speed motor for cooling SEER enhancement and continuous fan options for IAQ performance.
- Easy access to controls to connect power/control wiring.
- Built-in, high level self diagnostics with fault code display.
- Low unit amp requirement for easy replacement application.
- All models are convertible to use propane (LP) gas.
- Electronic Hot Surface Ignition saves fuel cost with increased dependability and reliability.
- 100% shut off main gas valve for extra safety.
- 24V, 40 VA control transformer and blower relay supplied for add-on cooling.
- Hi-tech tubular aluminized steel primary heat exchanger.
- Blower door safety switch.
- Solid removable bottom panel allows easy conversion.
- Low NOx models have been designed to meet specific code requirements.
- Airflow leakage less than 1% of nominal airflow for ductblaster conditions.
- No knockouts to deal with, making installation easier.
- Movable duct connector flanges for application flexibility.
- Quiet inducer operation.
- Inducer rotates for easy conversion of venting options.
- Fully supported blower assembly for easy access and removal of blower.
- External air filters used for maximum flexibility in meeting customers IAQ needs.
- Venting applications - may be installed as a common vent with other gas-fired appliances.
- Insulated blower compartment for quiet operation.
- 1/4 turn knobs provided for easy door removal.

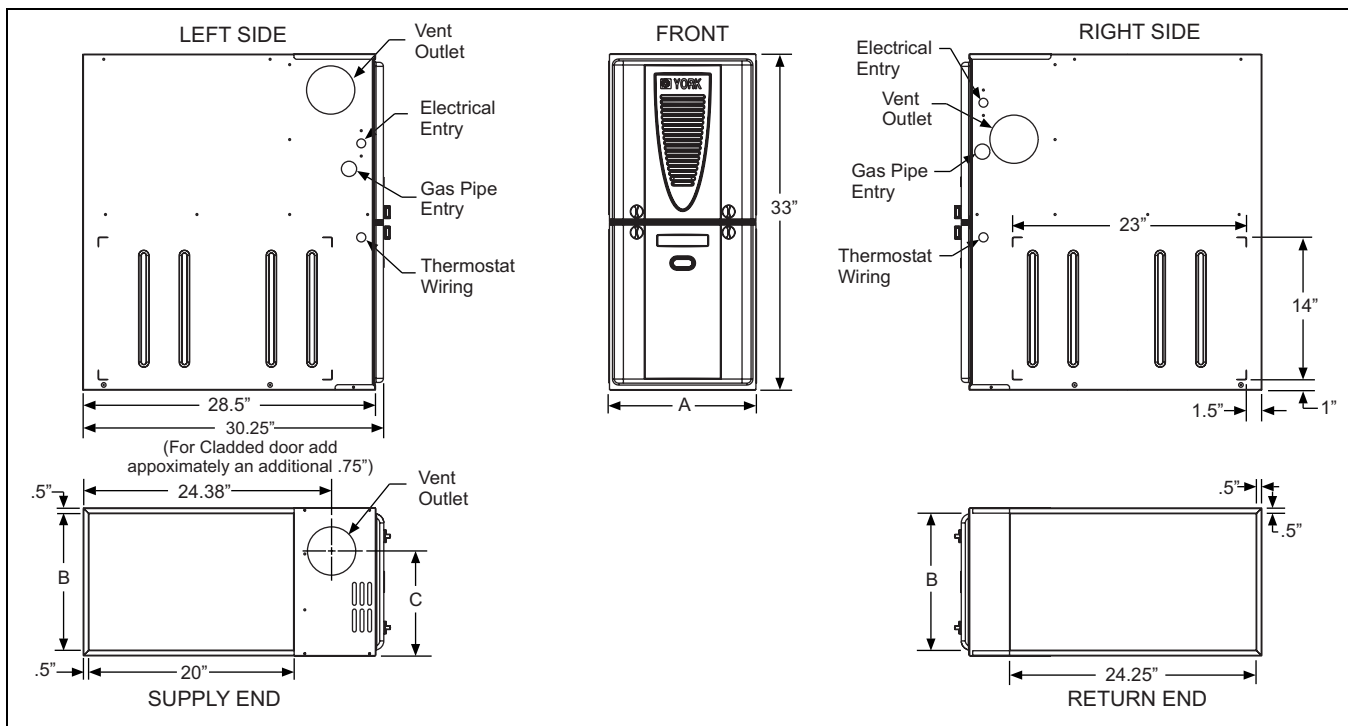

**Cabinet and Duct Dimensions**

Models	Nominal CFM (m <sup>3</sup> /min)	Cabinet Size	Cabinet Dimensions (Inches)			Approximate Operating Weights
			A	B	C	Lbs
YP(8,L)C060A12MP11	1200	A	14 1/2	13 1/4	10.3	94
YP(8,L)C080B12MP11	1200	B	17 1/2	16 1/4	11.8	103
YP(8,L)C080C16MP11	1600	C	21	19 3/4	13.6	114
YP(8,L)C100C16MP11	1600	C	21	19 3/4	13.6	118
YP(8,L)C100C20MP11	2000	C	21	19 3/4	13.6	122
YP(8,L)C120C20MP11	2000	C	21	19 3/4	15.8	129

**Ratings & Physical / Electrical Data**

Models	Input Max/Min	Output Max/Min	Nominal Airflow	Total Unit Amps	AFUE	Air Temp. Rise Max Input	Air Temp. Rise Min Input	Max Over-Current Protect	Min. wire Size (awg) @ 75 ft one way	Max. Outlet Air Temp
	MBH	MBH	CFM			°F	°F			°F
YP(8,L)C060A12MP11	60/30	48/24	1200	7.0	80.0	30-60	20-50	15	14	160
YP(8,L)C080B12MP11	80/40	64/32	1200	7.5	80.0	40-70	20-50	15	14	170
YP(8,L)C080C16MP11	80/40	64/32	1600	10.0	80.0	35-65	20-50	15	14	165
YP(8,L)C100C16MP11	100/50	80/40	1600	10.0	80.0	35-65	20-50	15	14	165
YP(8,L)C100C20MP11	100/50	80/40	2000	12.0	80.0	35-65	20-50	20	12	165
YP(8,L)C120C20MP11	120/60	96/48	2000	12.0	80.0	45-75	25-55	20	12	175

Annual Fuel Utilization Efficiency (AFUE) numbers are determined in accordance with DOE Test procedures. Wire size and over current protection must comply with the National Electrical Code (NFPA-70-latest edition) and all local codes.

## FILTER PERFORMANCE

The airflow capacity data published in the “Blower Performance” table represents blower performance WITHOUT filters.

All applications of these furnaces require the use of field installed air filters. All filter media and mounting hardware or provisions must be field installed external to the furnace cabinet. DO NOT attempt to install any filters inside the furnace.

**NOTE:** Single side return above 1800 CFM is approved as long as the filter velocity does not exceed filter manufacturer’s recommendation and a transition is used to allow use of a 20 x 25 filter.

## Recommended Filter Sizes

CFM	Cabinet Size	Side (in)	Bottom (in)
1200	A	16 x 25	14 x 25
1200	B	16 x 25	16 x 25
1600	C	16 x 25	20 x 25
2000	C	(2) 16 x 25	20 x 25

### NOTES:

- Air velocity through throwaway type filters may not exceed 300 feet per minute (91.4 m/min). All velocities over this require the use of high velocity filters.
- Do not exceed 1800 CFM using a single side return and a 16x25 filter. For CFM greater than 1800, you may use two side returns or one side and the bottom or one return with a transition to allow use of a 20x25 filter.

## Unit Clearances to Combustibles

Application	Top	Front	Rear	Left Side	Right Side	Flue	Floor/ Bottom	Closet	Alcove	Attic	Line Contact
Upflow B-Vent	1	3	0	0	0	1	Combustible	Yes	Yes	Yes	No
Downflow B-Vent	1	3	0	0	0	1	1 <sup>1</sup>	Yes	Yes	Yes	No
Horizontal B-Vent	1	3	0	0	0	1	Combustible	No	Yes	Yes	Yes <sup>2</sup>

- Special floor base or air conditioning coil required for use on combustible floor.
- Line contact only permitted between lines formed by the intersection of the rear panel and side panel (top in horizontal position) of the furnace jacket and building joists, studs or framing.

## ACCESSORIES

### PROPANE (LP) CONVERSION KIT -

1NP0680 - All Models

This accessory conversion kit may be used to convert natural gas (N) units for propane (LP) operation.

### SIDE RETURN FILTER RACKS -

1SR0200 - All Models

1SR0302 - All Models

1SF0101 - All Models

### BOTTOM RETURN FILTER RACKS -

1BR0514 or 1BR0614 - For 14-1/2” cabinets

1BR0517 or 1BR0617 - For 17-1/2” cabinets

1BR0521 or 1BR0621 - For 21” cabinets

1BR05xx series are galvanized steel filter racks. 1BR06xx are pre-painted steel filter racks to match the appearance of the furnace cabinet.

### COMBUSTIBLE FLOOR BASE KIT -

For installation of these furnaces in downflow applications directly onto combustible flooring material, These kits are required to prevent potential overheating situations. These kits are also required in any applications where the furnace is installed in a downflow configuration without an evaporator coil, where the combustible floor base kit provides access for combustible airflow.

1CB0514 - For 14-1/2” cabinets

1CB0517 - For 17-1/2” cabinets

1CB0521 - For 21” cabinets

### EAC TRANSITION KITS -

For installation of EAC accessories with these furnaces to provide easy transition of return airflow through the EAC to get the proper sealing and reduced airflow leakage.

1TK1001 - For all models using side return

1TK1014 - For 14-1/2” cabinets using bottom return

1TK1017 - For 17-1/2” cabinets using bottom return

1TK1021 - For 21” cabinets using bottom return

1TK1024 - For 24-1/2” cabinets using bottom return

**HIGH ALTITUDE** - No high altitude kits are required.

**ROOM THERMOSTATS** - A wide selection of compatible thermostats are available to provide optimum performance and features for any installation.

1H/1C, manual change-over electronic non-programmable thermostat.

1H/1C, auto/manual changeover, electronic programmable, deluxe 7-day, thermostat.

1H/1C, auto/manual changeover, electronic programmable.

\* For the most current accessory information, refer to the price book or consult factory.

## Blower Performance CFM - Any Position

High / Low Speed Cooling CFM					
060A12		080B12		Jumper Settings	
Hi Cool	Lo Cool	Hi Cool	Lo Cool	COOL Jumper	ADJ Jumper
1340	900	1290	790	A	B
1125	750	1065	660	B	B
1225	820	1165	720	A	A
1050	680	960	600	B	A
1100	740	1050	590	A	C
890	600	855	525	C	B
920	615	875	540	B	C
675	450	640	395	D	B
815	545	775	495	C	A
600	440	580	380	D	A
720	499	700	430	C	C
540	440	525	380	D	C
High / Low Speed Cooling CFM					
080C16		100C16		Jumper Settings	
Hi Cool	Lo Cool	Hi Cool	Lo Cool	COOL Jumper	ADJ Jumper
1715	1165	1600	1120	A	B
1520	1020	1450	980	B	B
1575	1060	1500	1020	A	A
1395	930	1345	900	B	A
1430	950	1315	930	A	C
1320	875	1265	845	C	B
1260	840	1210	805	B	C
1100	730	1080	700	D	B
1200	795	1165	765	C	A
1000	665	980	635	D	A
1080	715	1050	695	C	C
900	600	885	585	D	C
High / Low Speed Cooling CFM					
100C20		120C20		Jumper Settings	
Hi Cool	Lo Cool	Hi Cool	Lo Cool	COOL Jumper	ADJ Jumper
2110	1360	1990	1290	A	B
1670	1085	1760	1030	B	B
1900	1235	1900	1210	A	A
1515	990	1510	935	B	A
1710	1130	1800	1095	A	C
1465	950	1540	900	C	B
1370	890	1440	845	B	C
1255	815	1320	790	D	B
1330	865	1400	835	C	A
1140	740	1200	725	D	A
1195	780	1260	750	C	C
1025	665	1080	650	D	C

All CFM's are shown at 0.5" w.c. external static pressure. These units have variable speed motors that automatically adjust to provide constant CFM from 0.0" to 0.6" w.c. static pressure. From 0.6" to 1.0" static pressure, CFM is reduced by 2% per 0.1" increase in static. Operation on duct systems with greater than 1.0" w.c. external static pressure is not recommended.

**NOTE:** At some settings, LOW COOL airflow may be lower than what is required to operate an airflow switch on certain models of electronic air cleaners. Consult the instructions for the electronic air cleaner for further details.