

JOB NAME _____ LOCATION _____
 PURCHASER _____ ORDER NO. _____
 ENGINEER _____
 SUBMITTED TO _____ FOR: Reference Approval Construction
 SUBMITTED BY _____ DATE _____

UNIT DESIGNATION: Schedule No. _____ MODEL NO. _____

PRODUCT DATA

COOLING PERFORMANCE	
TOTAL CAPACITY	_____ MBH
SENSIBLE CAPACITY	_____ MBH
TOTAL SUPPLY AIR	_____ CFM
TEMP. OF AIR ENTERING	_____
EVAPORATOR COIL	_____ / _____ °F DB/WB
HEATING PERFORMANCE	
Refer to field-installed accessories on reverse side.	
SUPPLY AIR BLOWER PERFORMANCE	
TOTAL SUPPLY AIR	_____ CFM
TOTAL RESISTANCE EXTERNAL	_____
TO UNIT	_____ IWG
BLOWER SPEED	_____ RPM
POWER OUTPUT REQUIREMENT	_____ BHP
MOTOR RATING	_____ HP
POWER INPUT REQUIREMENT	_____ KW
ELECTRICAL DATA	
POWER SUPPLY	_____ / _____ / _____
TOTAL UNIT AMPACITY	_____ AMPS
MINIMUM WIRE SIZE	_____ AWG
(Copper Conductors)	
MAXIMUM FUSE SIZE	_____
DUAL ELEMENT	_____ AMPS
UNIT WEIGHT	
TOTAL OPERATING WEIGHT	_____ LBS.
(Including field-installed accessories)	

DIMENSIONS – INCHES

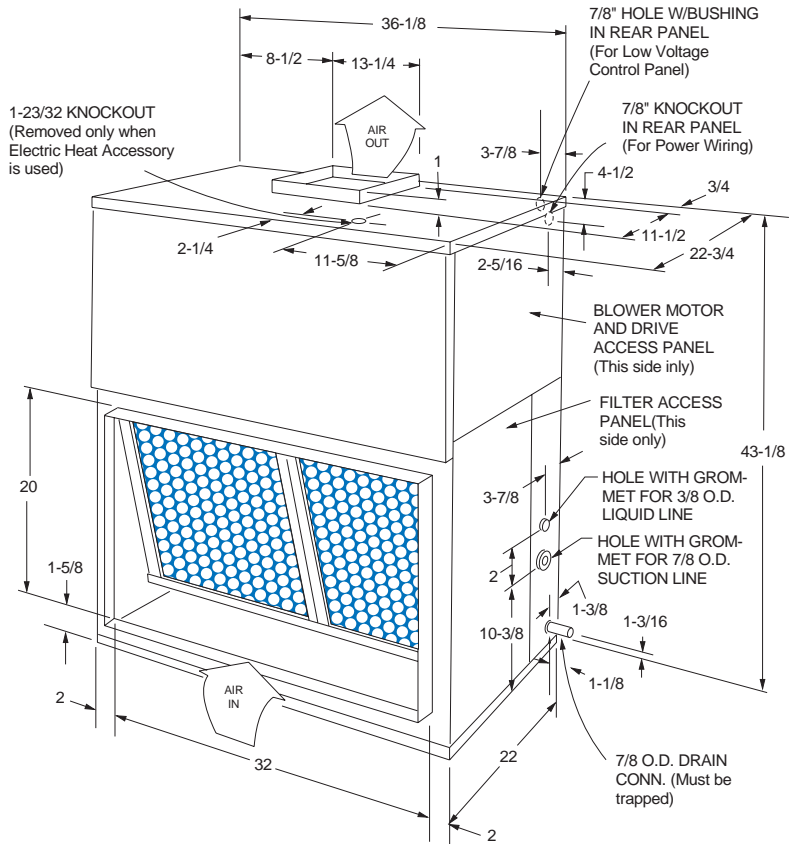

NOTE:
MATCHING CONDENSING UNIT DATA
 Model Number _____
 Submittal Form Number _____

MINIMUM CLEARANCES

- Side with RETURN AIR opening 24"
 - Side with SUPPLY AIR opening 24" ①
 - Side with PIPING CONNECTIONS 36" ②
 - Side opposite PIPING CONNECTIONS 12"
 - Side with access for both
 POWER & CONTROL WIRING ③
 - Bottom ④
- ① Overall dimension of the unit will vary if an electric heater, a supply air plenum or a base is used.
 ② This dimension is required for removal of the coil. Only 26" is required for normal servicing.
 ③ Although no clearance is required for service and operation, some clearance may be required for routing the power and control wiring.
 ④ Allow enough clearance to trap the condensate drain line.

APPLICATION

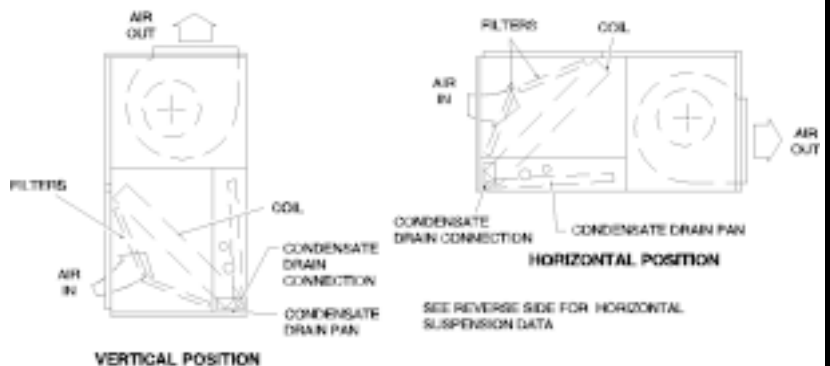

SPLIT-SYSTEM EVAPORATOR BLOWER
5 TONS
 MODEL K_EU060

FORM 550.13-SD13Y (199)

Supersedes: 550.13-SD13Y (1285)



FIELD-INSTALLED ACCESSORIES

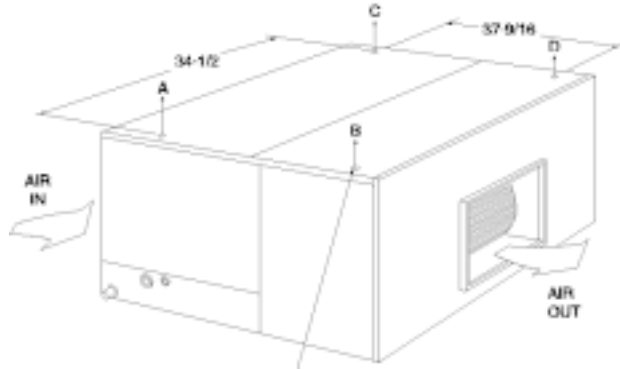

Four 3/8" - 16 weld nuts are provided in the unit support angles for ceiling suspension. Knockouts are provided in panels for access to these weld nuts. Support rods must be supplied in the field.

SUSPENSION WEIGHTS, LBS.			
A	B	C	D

- SUPPLY AIR PLENUM (1SP0450)
- RETURN AIR GRILLE (1RG0450)
- BASE (1BS0450)
(Vertical Application Only)
- ELECTRIC HEATER*
Model Number _____
Capacity (@ _____ Volts) MBH
Power Input Requirement KW
(Less Blower Motor)
- STEAM COIL (1NF0450)
Steam Pressure PSIG
Capacity MBH
Steam Rate LBS/HR
Entering Air Temperature °F
- HOT WATER COIL (1HW0450)
Capacity MBH
Entering Water Temperature °F
Water Flow Rate GPM
Entering Air Temperature °F
Water Pressure Drop PSI

* Units with electric heat have a single source power supply
Refer to PRODUCT DATA on front side for electrical data.

ACCESSORY DIMENSIONS – INCHES

ELECTRIC HEATER

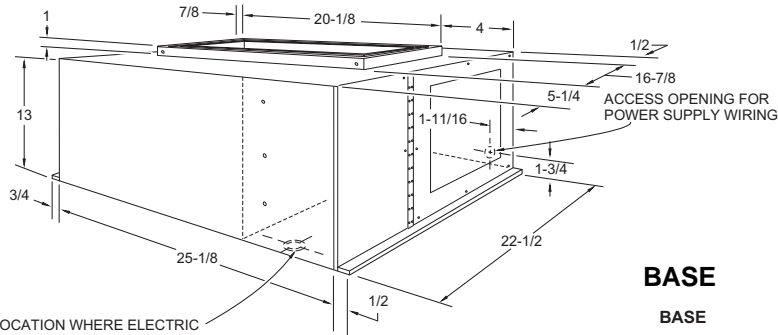

LOCATION WHERE ELECTRIC HEAT WIRING HARNESS PENETRATES THE CABINET OF THE BLOWER UNIT

BASE

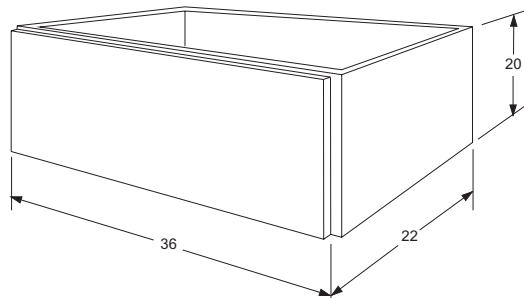

SUPPLY AIR PLENUM

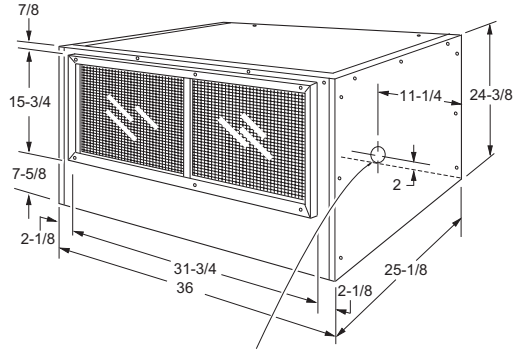

2-1/2 knockout for power wiring when electric heater is used

HOT WATER COIL

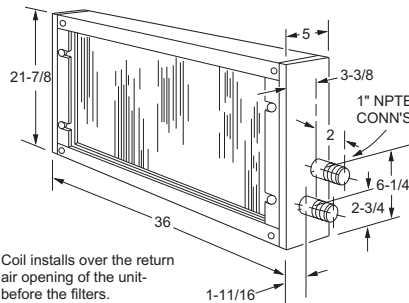

Coil installs over the return air opening of the unit before the filters.

STEAM COIL

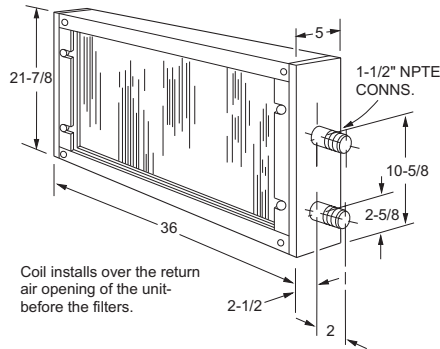

Coil installs over the return air opening of the unit before the filters.

RETURN AIR GRILLE

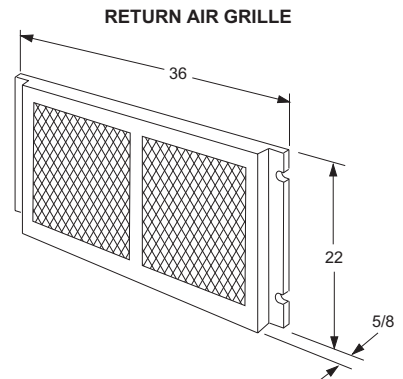

NOTES: _____

